

Linear Regulator

Linear Regulators Selection Guide

Ver.4.0



Power

ROHM Co.,Ltd.

INDEX

Single Output Linear Regulators	P.02
All Product Selection	P.02
Low Quiescent Current (I_Q) Products	P.02
Compact Products	P.03
High Accuracy Products	P.04
Low Saturation	P.04
AEC-Q100 Qualified Products	P.04
3-Pin Regulators	P.05
LDO Lineup	P.07
LDO System Diagram	P.13
Ultra-Low LDOs	P.16
Multi-Output LDOs	P.17
DDR SDRAM Termination Regulators	P.18
High Fidelity Audio Power Supplies	P.19
LDO+(plus)	P.21
Guide to ROHM's Website	P.24
Package List	P.25

Before using the ICs, please verify the numerical values, data, and functions listed in the latest datasheet.

Single Output Linear Regulators

All Product Selection

Rated Input Voltage(V)	Output Current(A)														
	0.1 to 0.15	No.	0.2	No.	0.3	No.	0.5	No.	1.0	No.	1.5	No.	2.0	No.	
45 to 50			BD7xxL2 ● 7 BD4xxM2 ● 9				BD7xxL5 ● 6 BD4xxM5 ● 8 BD357xY ● 5								
30 to 36	BDxxFA1 ●● 3				BD3650 ● 16		BA178Mxx ● 2		BA178xx ● 1 BAxxCC0 ● 14 BDxxFC0 ● 13 BDxxC0A ●● 15				BAxxDD0 ● 11 BDxxFD0 ● 10 BDxxD0A ● 12		
18									BAxxBC0 ● 18		BAxxJC5 ● 17				
15					BDxxGA3 ●●● 21		BDxxGA5 ●●● 20		BDxxGC0 ●●● 19 BA1117 ● 4						
10					BDxxHA3 ●●● 25		BDxxHA5 ●●● 24		BDxxHC0 ●●● 23		BDxxHC5 ●●● 22				
6 to 7	BHxxNB1 ● 37 BHxxPB1 ● 38 BHxxRB1 ● 40 BHxxSA3 ● 39		BUxxJA2 ● 36 BUxxSA4 ● 34 BUxxSD2 ● 35 BUxxTA2 ● 33 BUxxTD2 ● 32 BUxxTD3 ● 31				BDxxIA5 ●●● 27 BDxxKA5 ● 28 BUxxSA5 ● 30 BUxxSD5 ● 29		BDxxIC0 ●●● 26						

*No. : Indicates the series number within the lineup on pages 5 to 11.

Target Applications ● Consumer
● Industrial equipment
● Automotive

Low Quiescent Current (I_q) Product Selection

Rated Input Voltage(V)	Output Current(A)														
	0.1 to 0.15	No.	0.2	No.	0.3	No.	0.5	No.	1.0	No.	1.5	No.	2.0	No.	
45 to 50			BD7xxL2 6μA 7 BD4xxM2 40μA 9				BD7xxL5 6μA 6 BD4xxM5 38μA 8 BD357xY 30μA 5								
30 to 36	BDxxFA1 300μA 3				BD3650 500μA 16				BDxxFC0 500μA 13 BDxxC0A 500μA 15				BDxxFD0 500μA 10 BDxxD0A 500μA 12		
18															
15					BDxxGA3 600μA 21		BDxxGA5 600μA 20		BDxxGC0 600μA 19						
10					BDxxHA3 600μA 25		BDxxHA5 600μA 24		BDxxHC0 600μA 23		BDxxHC5 600μA 22				
6 to 7	BHxxNB1 60μA 37 BHxxPB1 2μA 38 BHxxRB1 34μA 40 BHxxSA3 40μA 39		BUxxJA2 33μA 36 BUxxSA4 40μA 34 BUxxSD2 33μA 35 BUxxTA2 40μA 33 BUxxTD2 35μA 32 BUxxTD3 35μA 31				BDxxIA5 250μA 27 BUxxSA5 33μA 30 BUxxSD5 33μA 29		BDxxIC0 250μA 26						

*No. : Indicates the series number within the lineup on pages 5 to 11.

Single Output Linear Regulators

Compact Product Selection

Rated Input Voltage(V)	Output Current(A)												
	0.1 to 0.15	No.	0.2	No.	0.3	No.	0.5	No.	1.0	No.	1.5	2.0	
45 to 50													
30 to 36													
18													
15					BDxxGA3 #B	21							
10													
6 to 7	BHxxNB1 #D BHxxPB1 #D BHxxRB1 #H BHxxSA3 #I	37 38 40 39	BUxxJA2 #A,#G BUxxSA4 #J BUxxSD2 #A BUxxTA2 #D,#E BUxxTD2 #F BUxxTD3 #A	36 34 35 33 32 31			BDxxIA5 #C BUxxSA5 #K BUxxSD5 #A	27 30 29	BDxxIC0 #C	26			

*No. : Indicates the series number within the lineup on pages 5 to 11.

#A **SSOP5 (SOT-23-5)***
2.9mm×2.8mm×1.25mm
*JEDEC



#B **VSON008X2030**
2.0mm×3.0mm×0.6mm



#C **HVSOF6**
1.6mm×3.0mm×0.75mm



#D **HVSOF5**
1.6mm×1.6mm×0.6mm



#E **SSON004X1216**
1.2mm×1.6mm×0.6mm



#F **SSON004X1010**
1.0mm×1.0mm×0.6mm



#G **SSON004R1010**
1.0mm×1.0mm×0.6mm



#H **VCSP60N1** **WL-CSP**
1.0mm×1.04mm×6mm
Pitch:0.5mm

#I **VCSP60N1** **WL-CSP**
0.96mm×0.96mm×0.6mm
Pitch:0.5mm

#J **UCSP50L1** **WL-CSP**
0.8mm×0.8mm×0.5mm
Pitch:0.4mm

#K **UCSP30L1** **WL-CSP**
0.8mm×0.8mm×0.33mm
Pitch:0.4mm

Smaller

Smaller

WL-CSP: Wafer level chip size package

High Accuracy Product Selection

Rated Input Voltage(V)		Output Current(A)													
		0.1 to 0.15	No.	0.2	No.	0.3	No.	0.5	No.	1.0	No.	1.5	No.	2.0	No.
45 to 50				BD7xxL2 $\pm 2\%^{*1}$ BD4xxM2 $\pm 2\%^{*1}$	7 9			BD7xxL5 $\pm 2\%^{*1}$ BD4xxM5 $\pm 2\%^{*1}$ BD357xY $\pm 2\%^{*1}$	6 8 5						
30 to 36	BDxxFA1 $\pm 2\%^{*1}$ $\pm 1\%^{*2}$	3				BD3650 $\pm 2\%^{*1}$	16			BDxxFC0 $\pm 1\%^{*2}$	13			BAxxDD0 $\pm 1\%^{*2}$ BDxxFD0 $\pm 1\%^{*2}$ BDxxD0A $\pm 1\%^{*2}$	11 10 12
18												BAxxJC5 $\pm 1\%^{*2}$	17		
15						BDxxGA3 $\pm 3\%^{*1}$ $\pm 1\%^{*2}$	21	BDxxGA5 $\pm 3\%^{*1}$ $\pm 1\%^{*2}$	20	BDxxGC0 $\pm 3\%^{*1}$ $\pm 1\%^{*2}$ BA1117 +1.6, -2% ^{*1}	19 4				
10						BDxxHA3 $\pm 3\%^{*1}$ $\pm 1\%^{*2}$	25	BDxxHA5 $\pm 3\%^{*1}$ $\pm 1\%^{*2}$	24	BDxxHC0 $\pm 3\%^{*1}$ $\pm 1\%^{*2}$	23	BDxxHC5 $\pm 3\%^{*1}$ $\pm 1\%^{*2}$	22		
6 to 7	BHxxNB1 $\pm 1\%^{*2}$ BHxxPB1 $\pm 1\%^{*2}$ BHxxRB1 $\pm 1\%^{*2}$ BHxxSA3 $\pm 1\%^{*2}$	37 38 40 39	BUxxJA2 $\pm 2\%^{*1}$ BUxxSA4 $\pm 0.6\%^{*2}$ BUxxSD2 $\pm 2\%^{*1}$ BUxxTA2 $\pm 1\%^{*2}$ BUxxTD2 $\pm 1\%^{*2}$ BUxxTD3 $\pm 1\%^{*2}$	36 34 35 33 32 31			BDxxIA5 $\pm 3\%^{*1}$ $\pm 1\%^{*2}$ BDxxKA5 $\pm 1\%^{*2}$ BUxxSA5 $\pm 1\%^{*2}$	27 28 30 29		BDxxIC0 $\pm 3\%^{*1}$ $\pm 1\%^{*2}$	26				

*No. : Indicates the series number within the lineup on pages 5 to 11.

*1 : Output voltage tolerance over the entire temperature range

*2 : Output voltage tolerance at +25°C

Low Saturation Selection

Rated Input Voltage(V)		Output Current(A)													
		0.1 to 0.15	0.2	No.	0.3	0.5	No.	1.0	No.	1.5	No.	2.0	No.		
45 to 50						BD4xxM5 67mV	8								
30 to 36								BDxxFC0 60mV BDxxC0A 60mV	13 15				BDxxFD0 40mV BDxxD0A 40mV	10 12	
18															
15								BDxxGC0 60mV	19						
10								BDxxHC0 60mV	23	BDxxHC5 40mV	22				
6 to 7			BUxxJA2 85mV BUxxSA4 80mV BUxxSD2 85mV	36 34 35		BDxxIA5 80mV BDxxKA5 60mV BUxxSA5 80mV BUxxSD5 85mV	27 28 30 29	BDxxIC0 40mV	26						

*No. : Indicates the series number within the lineup on pages 5 to 11.

*Input/output voltage tolerance when I_o=0.1A Please increase the value by 5x when I_o=0.5A. Please note that these values are approximate.

AEC-Q100 Qualified Products

Rated Input Voltage(V)		Output Current(A)													
		0.1 to 0.15	No.	0.2	No.	0.3	No.	0.5	No.	1.0	No.	1.5	No.	2.0	No.
45 to 50				BD7xxL2 Grade1 BD4xxM2 Grade1	7 9			BD7xxL5 Grade1 BD4xxM5 Grade1	6 8						
30 to 36	BDxxFA1 Grade2	3								BDxxC0A Grade1	15				
18															
15						BDxxGA3 Grade2	21	BDxxGA5 Grade2	20	BDxxGC0 Grade2	19				
10						BDxxHA3 Grade2	25	BDxxHA5 Grade2	24	BDxxHC0 Grade2	23	BDxxHC5 Grade2	22		
6 to 7			BUxxJA2 Grade1 BUxxSD2 Grade2	36 35				BDxxIA5 Grade2	27	BDxxIC0 Grade2	26				

*No. : Indicates the series number within the lineup on pages 5 to 11.

Grade1 : -40°C to +125°C

Grade2 : -40°C to +105°C

Single Output 3-Pin Linear Regulator Lineup

Series No.	Series	Rated Input (V)	Output Current (A)	Input Voltage (V)	Output Voltage(V)		Output Voltage Accuracy (%)	V _{REF} (V)	Current Consumption (mA)	Enable
					Variable	Fixed				
1	BA178xx/ BA78xx	35	1.0	7.5 to 33	—	5.0 / 6.0 / 7.0 / 8.0 / 9.0 / 10 / 12 / 15 / 18 / 20 / 24	±4	—	4.5	—
2	BA178Mxx/ BA78Mxx	35	0.5	7.5 to 33	—	5.0 / 6.0 / 7.0 / 8.0 / 9.0 / 10 / 12 / 15 / 18 / 20 / 24	±4	—	4.5	—
3	BDxxFA1	30	0.1	(Vo+3) to 25	3.0 to 12	—	±1	0.8	0.3	✓
					—	3.3 / 5.0 / 5.4 / 12	±1	—	0.3	—
					—	5.0	±2 ^{*1}	—	0.3	✓
4	BA1117	15	1.0	2.65 to 10	1.25 to 8.6	—	+1.6 -2 ^{*1}	1.25	1.7	—

*1 : Accuracy over the entire temperature range

*2 : xx are placeholders for alphanumeric characters that correspond to the output voltage

ROHM offers a lineup of fixed output products equivalent to the industry standard μ A7800 series of fixed output positive voltage power supplies released by Fairchild in 1976.

A wide range of output voltages is available, including 5V-10V, 12V, 15V, 18V, 20V, and 24V, with an output voltage accuracy of less than $\pm 4\%$. Users can select from among 3 output currents 100mA (BDxxFA1), 500m (BA178Mxx), and 1A (BA178xx). An input-output voltage difference of around 2-3V is needed. However, models equivalent to the μ A7900 series of fixed negative voltage output power supplies are not available.

Part Number Explanation

B **A** **1** **7** **8** **M** **0** **5** **CP**

Series

178: Fixed Positive Output
78xx series

Output Current

[Blank] : 1A
M : 500mA

Output Voltage

05 : 5.0V
06 : 6.0V
.
.
24 : 24V

Package

CP : TO220CP-3
FP : TO252-3

78xx series

Pin-Compatible

μ A78xx, LM78xx, MC78xx, AS78xx, SP78xx, KA78xx, IFX78xx, NJM78xx, NCV78xx, L78xx, TA78xx etc.

BA178xx series

- V_{IN} Max. : 35V
- V_{IN} : 7.5V to 33V
- I_o : 1A
- V_o : 5V/6V/7V/8V/9V/10V/12V/15V/18V/20V/24V
- Output Accuracy : $\pm 4\%$
- Overcurrent Protection, Thermal Shutdown, Safe Operating Area Limiting Circuit

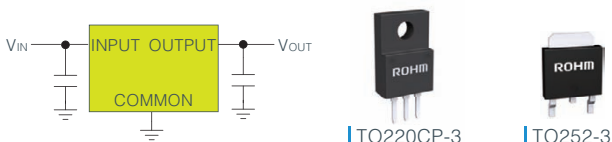

78Mxx series

Pin-Compatible

μ A78Mxx, LM78Mxx, MC78Mxx, KA78Mxx, IFX78Mxx, NJM78Mxx, AN78Mxx, L78Mxx, TA78Mxx etc.

BA178Mxx series

- V_{IN} Max. : 35V
- V_{IN} : 7.5V to 33V
- I_o : 500mA
- V_o : 5V/6V/7V/8V/9V/10V/12V/15V/18V/20V/24V
- Output Accuracy : $\pm 4\%$
- Overcurrent Protection, Thermal Shutdown, Safe Operating Area Limiting Circuit

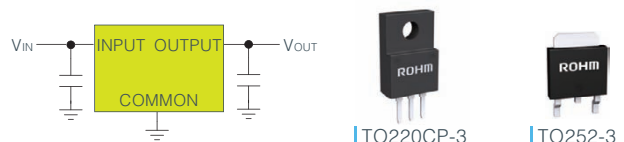

Functions						Other	Operating Temperature Ta (°C)	Package	Target Applications			Series Name*2
Output Ceramic Capacitor Compatibility	Soft Start	Output Discharge	Overcurrent Protection	Thermal Shutdown	Overvoltage Protection				Consumer	Industrial Equipment	Automotive	
✓	—	—	✓	✓	✓	—	−40 to +85	TO220CP-3	✓	—	—	BA178xxCP/ BA78xxCP
								TO252-3	✓	—	—	BA178xxFP/ BA78xxFP
✓	—	—	✓	✓	✓	—	−40 to +85	TO220CP-3	✓	—	—	BA178MxxCP/ BA78MxxCP
								TO252-3	✓	—	—	BA178MxxFP/ BA78MxxFP
✓	✓	—	✓	✓	—	—	−25 to +85	HTSOP-J8	✓	—	—	BD00FA1WEFJ
✓	✓	—	✓	✓	—	—	−25 to +85	SOT89-3K	✓	—	—	BDxxFA1FP3
✓	✓	—	✓	✓	—	AEC-Q100	−40 to +105	SSOP5	—	—	✓	BDxxFA1MG-M
✓	—	—	✓	✓	—	—	−20 to +105	TO252-3	✓	—	—	BA1117FP

ROHM offers a lineup of variable output products equivalent to the low saturation output LM1117 series, which is the successor to the industry standard LM317 series released by National Semiconductor in 1977.

The input-output voltage difference ranges from around 2V for conventional products to 1.2V with LDOs. Features include a wide output voltage range from 1.25V to 8.6V with an output voltage accuracy of less than ±1% and an output current of 1A.

Part Number Explanation

B **D** **0** **0** **F** **A** **1** **W** **EFJ**

Output Voltage

00 : Variable
33 : 3.3V
54 : 5.4V
J2 : 12V

Package

FP3 : SOT89-3K
G : SSOP5
EFJ : HTSOP-J8

Rating

F : 30V

Output Current

A1 : 100mA

Enable

[Blank] : None
W, M : There

78Lxx series

Pin-Compatible

μA78Lxx, LM78Lxx, MC78Lxx, AS78Lxx, AP78Lxx, ZR78Lxx, SP78Lxx, KA78Lxx, NJM78Lxx, AN78Lxx, L78Lxx, TA78Lxx etc.

BDxxFA1 series

- VIN Max. : 30V
- VIN : (Vo+3)V to 25V
- I_o : 100mA
- Vo : 3.3V/5V/5.4V/12V
- Output Accuracy : ±1%
- Output Ceramic Capacitor Compatibility
- Soft Start
- Overcurrent Protection, Thermal Shutdown

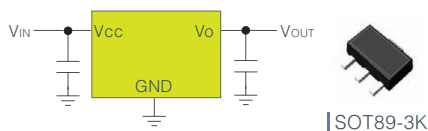

1117 series

Pin-Compatible

LM1117, AP1117, ZLDO1117, AZ1117, SPX1117, RC1117, FAN1117, IFX1117, IRU1117, LT1117, NX1117 etc.

BA1117

- VIN Max. : 15V
- VIN : 2.65V to 10V
- I_o : 1A
- Vo : 1.25V to 8.6V可変
- Output Accuracy : ±1%
- Output Ceramic Capacitor Compatibility
- Overcurrent Protection, Thermal Shutdown

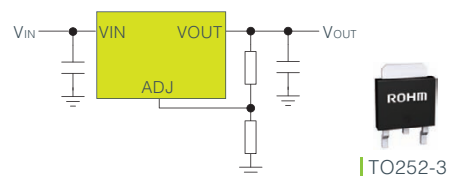

Single Output LDO-Type Linear Regulator Lineup

30V to 50V Rated Input

Series No.	Series	Rated Input (V)	Output Current (A)	Input Voltage (V)	Output Voltage(V)		Output Voltage Accuracy (%)	V _{REF} (V)	Current Consumption	Enable	Output Ceramic Capacitor Compatibility
					Variable	Fixed					
5	BD357xY	50	0.5	4.5 to 36	—	3.3 / 5.0	±2 ^{*1}	—	30μA	—	✓
					2.8 to 12	3.3 / 5.0	±2 ^{*1}	1.26	30μA	✓	✓
					2.8 to 12	3.3 / 5.0	±2 ^{*1}	1.26	30μA	✓	✓
6	BD7xxL5	50	0.5	4.17 to 45	—	3.3 / 5.0	±2 ^{*1}	—	6μA	—	✓
7	BD7xxL2	50	0.2	4.37 to 45	—	3.3 / 5.0	±2 ^{*1}	—	6μA	—	✓
8	BD4xxM5	45	0.5	4.0 to 42	—	3.3 / 5.0	±2 ^{*1}	—	38μA	—	✓
										✓	✓
9	BD4xxM2	45	0.2	3.9 to 42	—	3.3 / 5.0	±2 ^{*1}	—	40μA	—	✓
										✓	✓
10	BDxxFD0	35	2.0	4.0 to 32	1.5 to 16	1.5 / 1.8 / 2.5 / 3.0 / 3.3 / 5.0 / 8.0 / 9.0 / 12 / 15 / 16	±1	0.75	0.5mA	✓	✓
11	BAxxDD0	35	2.0	3.0 to 25	—	—	±1	—	0.9mA	—	—
					1.5 to 16	—	±1	1.27	0.9mA	✓	—
					—	1.5 / 1.8 / 2.5 / 3.0 / 3.3 / 5.0 / 9.0 / 12 / 16	±1	—	0.9mA	✓	—
					1.5 to 16	1.5 / 1.8 / 2.5 / 3.0 / 3.3 / 5.0 / 9.0 / 12 / 16	±1	1.27	0.9mA	✓	—
12	BDxxD0A	35	2.0	4.0 to 25	3.0 to 15	—	±1	0.75	0.5mA	✓	✓
13	BDxxFC0	35	1.0	4.0 to 26.5	—	3.3 / 5.0	±1	0.75	0.5mA	—	✓
					1.0 to 15	1.5 / 1.8 / 2.5 / 3.0 / 3.3 / 5.0 / 8.0 / 9.0 / 12 / 15 / 16	±1	0.75	0.5mA	✓	✓
14	BAxxCC0	35	1.0	4.0 to 25	—	3.0 / 3.3 / 5.0 / 6.0 / 7.0 / 8.0 / 9.0 / 10 / 12 / 15	±2	—	2.5mA	—	—
					3.0 to 15	—	±2	1.225	2.5mA	✓	—
					3.0 to 15	3.0 / 3.3 / 5.0 / 7.0 / 8.0 / 9.0 / 10 / 12	±2	1.225	2.5mA	✓	—
						3.3 / 5.0 / 6.0 / 7.0 / 8.0 / 9.0 / 12	±2	1.225	2.5mA	✓	—
15	BDxxC0A	35	1.0	(V _O +1.0) to 26.5	—	8.0 / 9.0	±1	—	0.5mA	—	✓
					—	8.0	±3 ^{*1}	—	0.5mA	—	✓
					—	3.3 / 5.0 / 8.0 / 9.0	±3 ^{*1}	—	0.5mA	—	✓
					—	3.3 / 5.0	±1	—	0.5mA	✓	✓
					1.0 to 15	3.3 / 5.0 / 8.0 / 9.0	±3 ^{*1}	0.75	0.5mA	✓	✓
16	BD3650	36	0.3	5.6 to 30	—	5.0	±2 ^{*1}	—	0.5mA	—	✓
3	BDxxFA1	30	0.1	(V _O +3) to 25	3.0 to 12	—	±1	0.8	0.3mA	✓	✓
					—	3.3 / 5.0 / 5.4 / 12	±1	—	0.3mA	—	✓
					—	5.0	±2 ^{*1}	—	0.3mA	✓	✓

*1 : Accuracy over the entire temperature range

*2 : xx are placeholders for alphanumeric characters that correspond to the output voltage

Functions					Other	Operating Temperature T _a (°C)	Package	Target Applications			Series Name*2
Soft Start	Output Discharge	Overcurrent Protection	Thermal Shutdown	Overvoltage Protection				Consumer	Industrial Equipment	Automotive	
—	—	✓	✓	—	—	–40 to +125	TO252-3	—	—	✓	BD357xYFP-M
—	—	✓	✓	—	—	–40 to +125	TO252-5	—	—	✓	BD357xYFP-M
—	—	✓	✓	—	—	–40 to +125	HRP5	—	—	✓	BD357xYHFP-M
—	—	✓	✓	—	AEC-Q100	–40 to +125	TO252-3	—	—	✓	BD7xxL5FP-C
—	—	✓	✓	—	AEC-Q100	–40 to +125	HTSOP-J8	—	—	✓	BD7xxL2EFJ-C
							TO252-3	—	—	✓	BD7xxL2FP-C
							SOT223-4	—	—	✓	BD7xxL2FP3-C
—	—	✓	✓	—	AEC-Q100	T _j –40 to +150	TO252-3	—	—	✓	BD4xxM5FP-C
							TO263-3	—	—	✓	BD4xxM5FP2-C
—	—	✓	✓	—	AEC-Q100	T _j –40 to +150	TO252-J5	—	—	✓	BD4xxM5WFPJ-C
							TO263-5	—	—	✓	BD4xxM5WFP2-C
—	—	✓	✓	—	AEC-Q100	T _j –40 to +150	SOT223-4	—	—	✓	BD4xxM2FP3-C
							HTSOP-J8	—	—	✓	BD4xxM2EFJ-C
—	—	✓	✓	—	AEC-Q100	T _j –40 to +150	SOT223-4	—	—	✓	BD4xxM2WFP3-C
							HTSOP-J8	—	—	✓	BD4xxM2WEFJ-C
—	—	✓	✓	—	—	–25 to +85	HRP5	✓	—	—	BDxxFD0WHFP
							TO263-5	✓	—	—	BDxxFD0WFP2
—	—	✓	✓	✓	—	–40 to +125	TO220FP-3	✓	—	—	BAxxDD0T
—	—	✓	✓	✓	—	–40 to +125	TO220CP-V5	✓	—	—	BA00DD0WCP-V5
—	—	✓	✓	✓	—	–40 to +125	TO220FP-5	✓	—	—	BAxxDD0WT
—	—	✓	✓	✓	—	–40 to +125	HRP5	✓	—	—	BAxxDD0WHFP
—	—	✓	✓	—	—	–40 to +105	HRP5	✓	—	—	BD00D0AWHFP
—	—	✓	✓	—	—	–25 to +85	TO252-3	✓	—	—	BDxxFC0FP
							HTSOP-J8	✓	—	—	BDxxFC0WEFJ
—	—	✓	✓	—	—	–25 to +85	TO252-5	✓	—	—	BDxxFC0WFP
							TO220FP-3	✓	—	—	BAxxCC0T
—	—	✓	✓	✓	—	–40 to +125	TO252-3	✓	—	—	BAxxCC0FP
							TO220CP-V5	✓	—	—	BA00CC0WCP-V5
—	—	✓	✓	✓	—	–40 to +125	TO220FP-5(V5)	✓	—	—	BA00CC0WT-V5
							TO220FP-5	✓	—	—	BAxxCC0WT
—	—	✓	✓	✓	—	–40 to +125	TO252-5	✓	—	—	BAxxCC0WFP
—	—	✓	✓	—	—	–40 to +105	TO252S-3	✓	—	—	BDxxC0AFPS
—	—	✓	✓	—	AEC-Q100	–40 to +125	TO252S-3	—	—	✓	BD80C0AFPS-C
—	—	✓	✓	—	AEC-Q100	–40 to +125	TO252-3	—	—	✓	BDxxC0AFP-C
							HRP5	—	—	✓	BDxxC0AHFP-C
							TO263-3	—	—	✓	BDxxC0AFP2-C
—	—	✓	✓	—	—	–40 to +105	TO252-5	✓	—	—	BDxxC0AWFP
—	—	✓	✓	—	AEC-Q100	–40 to +125	TO252-5	—	—	✓	BDxxC0AWFP-C
							HRP5	—	—	✓	BDxxC0AHFP-C
							TO263-5	—	—	✓	BDxxC0AWFP2-C
—	—	✓	✓	—	—	–40 to +125	TO252-3	—	—	✓	BD3650FP-M
✓	—	✓	✓	—	—	–25 to +85	HTSOP-J8	✓	—	—	BD00FA1WEFJ
✓	—	✓	✓	—	—	–25 to +85	SOT89-3K	✓	—	—	BDxxFA1FP3
✓	—	✓	✓	—	AEC-Q100	–40 to +105	SSOP5	—	—	✓	BDxxFA1MG-M

Single Output LDO-Type Linear Regulator Lineup

7V to 18V Rated Input

Series No.	Series	Rated Input (V)	Output Current (A)	Input Voltage (V)	Output Voltage(V)		Output Voltage Accuracy (%)	V _{REF} (V)	Current Consumption (mA)	Enable	Output Ceramic Capacitor Compatibility
					Variable	Fixed					
17	BAxxJC5	18	1.5	3.0 to 16	—	1.5 / 1.8 / 2.5 / 3.0 / 3.3 / 5.0 / 6.0 / 6.3 / 8.0 / 9.0 / 12	±1	—	0.5	—	—
					1.5 to 12	—	±1	1.25	0.5	✓	—
18	BAxxBC0	18	1.0	3.0 to 16	—	1.5 / 1.8 / 2.5 / 3.0 / 3.3 / 5.0 / 6.0 / 7.0 / 8.0 / 9.0 / 10	±2	—	0.5	—	—
					1.5 to 12	1.5 / 1.8 / 2.5 / 3.0 / 3.3 / 5.0 / 6.0 / 7.0 / 8.0 / 9.0 / 10	±2	1.25	0.5	✓	—
						—	±2	1.25	0.5	✓	—
19	BDxxGC0	15	1.0	4.5 to 14	1.5 to 13	1.5 / 1.8 / 2.5 / 3.0 / 3.3 / 5.0 / 6.0 / 7.0 / 8.0 / 9.0 / 10 / 12	±1	0.8	0.6	✓	✓
							±3 ^{*1}	0.8	0.6	✓	✓
							±3 ^{*1}	0.8	0.6	✓	✓
20	BDxxGA5	15	0.5	4.5 to 14	1.5 to 13	1.5 / 1.8 / 2.5 / 3.0 / 3.3 / 5.0 / 6.0 / 7.0 / 8.0 / 9.0 / 10 / 12	±1	0.8	0.6	✓	✓
							±3 ^{*1}	0.8	0.6	✓	✓
							±3 ^{*1}	0.8	0.6	✓	✓
21	BDxxGA3W	15	0.3	4.5 to 14	1.5 to 13	1.5 / 1.8 / 2.5 / 3.0 / 3.3 / 5.0 / 6.0 / 7.0 / 8.0 / 9.0 / 10 / 12	±1	0.8	0.6	✓	✓
							±3 ^{*1}	0.8	0.6	✓	✓
							±3 ^{*1}	0.8	0.6	✓	✓
22	BDxxHC5	10	1.5	4.5 to 8.0	1.5 to 7.0	1.5 / 1.8 / 2.5 / 3.0 / 3.3 / 5.0 / 6.0 / 7.0	±1	0.8	0.6	✓	✓
							±3 ^{*1}	0.8	0.6	✓	✓
							±3 ^{*1}	0.8	0.6	✓	✓
23	BDxxHC0	10	1.0	4.5 to 8.0	0.8 to 7.0	1.5 / 1.8 / 2.5 / 3.0 / 3.3 / 5.0 / 6.0 / 7.0	±1	0.8	0.6	✓	✓
					1.5 to 7.0		±3 ^{*1}	0.8	0.6	✓	✓
					1.5 to 7.0		±3 ^{*1}	0.8	0.6	✓	✓
24	BDxxHA5	10	0.5	4.5 to 8.0	1.5 to 7.0	1.5 / 1.8 / 2.5 / 3.0 / 3.3 / 5.0 / 6.0 / 7.0	±1	0.8	0.6	✓	✓
							±3 ^{*1}	0.8	0.6	✓	✓
							±3 ^{*1}	0.8	0.6	✓	✓
25	BDxxHA3	10	0.3	4.5 to 8.0	1.5 to 7.0	1.5 / 1.8 / 2.5 / 3.0 / 3.3 / 5.0 / 6.0 / 7.0	±1	0.8	0.6	✓	✓
							±3 ^{*1}	0.8	0.6	✓	✓
							±3 ^{*1}	0.8	0.6	✓	✓
26	BDxxIC0	7	1.0	2.4 to 5.5	0.8 to 4.5	1.0 / 1.2 / 1.25 / 1.5 / 1.8 / 2.5 / 2.6 / 3.0 / 3.3	±1	0.8	0.25	✓	✓
							±3 ^{*1}	0.8	0.25	✓	✓
							±3 ^{*1}	0.8	0.25	✓	✓
27	BDxxIA5	7	0.5	2.4 to 5.5	0.8 to 4.5	1.0 / 1.2 / 1.5 / 1.8 / 2.5 / 3.0 / 3.3	±1	0.8	0.25	✓	✓
							±3 ^{*1}	0.8	0.25	✓	✓
							±3 ^{*1}	0.8	0.25	✓	✓
28	BDxxKA5	7	0.5	2.3 to 5.5	—	1.0 / 1.2 / 1.5 / 1.8 / 2.5 / 3.0 / 3.3	±1	—	0.35	—	✓
					1.0 to 4.0	1.0 / 1.2 / 1.5 / 1.8 / 2.5 / 3.0 / 3.3	±1	0.75	0.35	✓	✓

*1 : Accuracy over the entire temperature range

*2 : xx are placeholders for alphanumeric characters that correspond to the output voltage

Functions					Other	Operating Temperature T _a (°C)	Package	Target Applications			Series Name ²
Soft Start	Output Discharge	Overcurrent Protection	Thermal Shutdown	Overvoltage Protection				Consumer	Industrial Equipment	Automotive	
—	—	✓	✓	—	—	−40 to +105	TO220FP-3	✓	—	—	BAxxJC5T
—	—	✓	✓	—	—	−40 to +105	TO220FP-5	✓	—	—	BA00JC5WT
—	—	✓	✓	—	—	−40 to +105	TO252-3	✓	—	—	BAxxBC0FP
—	—	✓	✓	—	—	−40 to +105	TO220FP-3	✓	—	—	BAxxBC0T
—	—	✓	✓	—	—	−40 to +105	TO252-5	✓	—	—	BAxxBC0WFP
—	—	✓	✓	—	—	−40 to +105	TO220FP-5	✓	—	—	BAxxBC0WT
—	—	✓	✓	—	—	−40 to +105	TO220FP-5(V5)	✓	—	—	BAxxBC0WT-V5
—	—	✓	✓	—	—	−40 to +105	TO220CP-V5	✓	—	—	BAxxBC0WCP-V5
✓	—	✓	✓	—	—	−25 to +85	HTSOP-J8	✓	—	—	BDxxGC0WEFJ
✓	—	✓	✓	—	—	−40 to +105	HTSOP-J8	—	✓	—	BDxxGC0MEFJ-LB
✓	—	✓	✓	—	AEC-Q100	−40 to +105	HTSOP-J8	—	—	✓	BDxxGC0MEFJ-M
✓	—	✓	✓	—	—	−25 to +85	HTSOP-J8	✓	—	—	BDxxGA5WEFJ
✓	—	✓	✓	—	—	−40 to +105	HTSOP-J8	—	✓	—	BDxxGA5MEFJ-LB
✓	—	✓	✓	—	AEC-Q100	−40 to +105	HTSOP-J8	—	—	✓	BDxxGA5MEFJ-M
✓	—	✓	✓	—	—	−25 to +85	HTSOP-J8	✓	—	—	BDxxGA3WEFJ
✓	—	✓	✓	—	—	−25 to +85	VSON008X2030	✓	—	—	BDxxGA3WNUX
✓	—	✓	✓	—	—	−40 to +105	HTSOP-J8	—	✓	—	BDxxGA3MEFJ-LB
✓	—	✓	✓	—	AEC-Q100	−40 to +105	HTSOP-J8	—	—	✓	BDxxGA3MEFJ-M
✓	—	✓	✓	—	—	−25 to +85	HTSOP-J8	✓	—	—	BDxxHC5WEFJ
✓	—	✓	✓	—	—	−40 to +105	HTSOP-J8	—	✓	—	BDxxHC5MEFJ-LB
✓	—	✓	✓	—	AEC-Q100	−40 to +105	HTSOP-J8	—	—	✓	BDxxHC5MEFJ-M
✓	—	✓	✓	—	—	−25 to +85	HTSOP-J8	✓	—	—	BDxxHC0WEFJ
✓	—	✓	✓	—	—	−40 to +105	HTSOP-J8	—	✓	—	BDxxHC0MEFJ-LB
✓	—	✓	✓	—	AEC-Q100	−40 to +105	HTSOP-J8	—	—	✓	BDxxHC0MEFJ-M
✓	—	✓	✓	—	—	−25 to +85	HTSOP-J8	✓	—	—	BDxxHA5WEFJ
✓	—	✓	✓	—	—	−40 to +105	HTSOP-J8	—	✓	—	BDxxHA5MEFJ-LB
✓	—	✓	✓	—	AEC-Q100	−40 to +105	HTSOP-J8	—	—	✓	BDxxHA5MEFJ-M
✓	—	✓	✓	—	—	−25 to +85	HTSOP-J8	✓	—	—	BDxxHA3WEFJ
✓	—	✓	✓	—	—	−40 to +105	HTSOP-J8	—	✓	—	BDxxHA3MEFJ-LB
✓	—	✓	✓	—	AEC-Q100	−40 to +105	HTSOP-J8	—	—	✓	BDxxHA3MEFJ-M
✓	—	✓	✓	—	—	−25 to +85	HVSOF6	✓	—	—	BDxxIC0WHFV
✓	—	✓	✓	—	—	−25 to +85	HTSOP-J8	✓	—	—	BDxxIC0WEFJ
✓	—	✓	✓	—	—	−40 to +105	HTSOP-J8	—	✓	—	BDxxIC0MEFJ-LB
✓	—	✓	✓	—	AEC-Q100	−40 to +105	HTSOP-J8	—	—	✓	BDxxIC0MEFJ-M
✓	—	✓	✓	—	—	−25 to +85	HTSOP-J8	✓	—	—	BDxxIA5WEFJ
✓	—	✓	✓	—	—	−40 to +105	HTSOP-J8	—	✓	—	BDxxIA5MEFJ-LB
✓	—	✓	✓	—	AEC-Q100	−40 to +105	HTSOP-J8	—	—	✓	BDxxIA5MEFJ-M
✓	—	✓	✓	—	AEC-Q100	−40 to +105	HVSOF6	—	—	✓	BD00IA5MHFV-M
—	—	✓	✓	—	—	−40 to +105	TO252-3	✓	—	—	BDxxKA5FP
—	—	✓	✓	—	—	−40 to +105	TO252-5	✓	—	—	BDxxKA5WFP
—	—	✓	✓	—	—	−40 to +105	SOP8	✓	—	—	BDxxKA5WFP

Single Output LDO-Type Linear Regulator Lineup

5.5V to 6.5V Rated Input

Series No.	Series	Rated Input (V)	Output Current (A)	Input Voltage (V)	Output Voltage(V)		Output Voltage Accuracy (%)	V _{REF} (V)	Current Consumption (μA)	Enable	Output Ceramic Capacitor Compatibility
					Variable	Fixed					
29	BUxxSD5	6.5	0.5	1.7 to 6.0	—	1.8 / 3.3	±2	—	33	✓	✓
30	BUxxSA5	5.5	0.5	1.8 to 5.0	—	3.0 / 3.3	±1	—	33	✓	✓
31	BUxxTD3	6.5	0.2	1.7 to 6.0	—	1.0 / 1.1 / 1.2 / 1.25 / 1.3 / 1.5 / 1.8 / 1.85 / 1.9 / 2.0 / 2.1 / 2.5 / 2.6 / 2.7 / 2.8 / 2.85 / 2.9 / 3.0 / 3.1 / 3.2 / 3.3	±1	—	35	✓	✓
32	BUxxTD2	6.5	0.2	1.7 to 6.0	—	1.0 / 1.05 / 1.1 / 1.15 / 1.2 / 1.25 / 1.3 / 1.5 / 1.8 / 1.85 / 1.9 / 2.0 / 2.05 / 2.1 / 2.3 / 2.5 / 2.6 / 2.7 / 2.75 / 2.8 / 2.85 / 2.9 / 3.0 / 3.1 / 3.2 / 3.3	±1	—	35	✓	✓
33	BUxxTA2	6.5	0.2	2.5 to 5.5	—	1.5 / 1.8 / 2.5 / 2.6 / 2.7 / 2.8 / 2.85 / 2.9 / 3.0 / 3.1 / 3.2 / 3.3	±1	—	40	✓	✓
34	BUxxSA4	6.5	0.2	1.7 to 5.5	—	1.8 / 2.5 / 2.55 / 2.8 / 3.0 / 3.3	±0.6	—	40	✓	✓
35	BUxxSD2	6.5	0.2	1.7 to 6.0	—	1.2 / 1.5 / 1.8 / 2.5 / 2.8 / 3.0 / 3.3	±2 ^{*1}	—	33	✓	✓
36	BUxxJA2	6.5	0.2	1.7 to 6.0	—	1.0 / 1.1 / 1.2 / 1.25 / 1.5 / 1.8 / 2.5 / 2.8 / 2.85 / 2.9 / 3.0 / 3.3 / 3.4	±2 ^{*1}	—	35	✓	✓
						1.0 / 1.2 / 1.25 / 1.5 / 1.8 / 2.5 / 2.8 / 2.85 / 3.0 / 3.3	±2 ^{*1}	—	33	✓	✓
						1.0 / 1.2 / 1.25 / 1.5 / 1.8 / 2.5 / 2.8 / 2.85 / 3.0 / 3.3	±2 ^{*1}	—	33	✓	✓
37	BHxxNB1	6	0.15	2.5 to 5.5	—	2.5 / 2.8 / 2.85 / 2.9 / 3.0 / 3.1 / 3.3	±1	—	60	✓	✓
38	BHxxPB1	6.5	0.15	1.7 to 5.5	—	1.2 / 1.5 / 1.8 / 2.5 / 2.8 / 2.9 / 3.0 / 3.1 / 3.3	±1	—	2	✓	✓
39	BHxxSA3	6.5	0.15	2.2 to 5.5	—	1.8 / 2.8 / 3.0	±1	—	40	✓	✓
40	BHxxRB1	6.5	0.15	2.5 to 5.5	—	1.5 / 1.8 / 2.5 / 2.8 / 2.9 / 3.0 / 3.1 / 3.3	±1	—	34	✓	✓

*1 : Accuracy over the entire temperature range

*2 : xx are placeholders for alphanumeric characters that correspond to the output voltage

Functions					Other	Operating Temperature T _a (°C)	Package	Target Applications			Series Name*2
Soft Start	Output Discharge	Overcurrent Protection	Thermal Shutdown	Overvoltage Protection				Consumer	Industrial Equipment	Automotive	
—	✓	✓	✓	—	—	–40 to +105	SSOP5	✓	—	—	BUxxSD5WG
—	—	✓	✓	—	—	–40 to +105	UCSP30L1 (0.8×0.8×0.33)	✓	—	—	BUxxSA5WGWZ
—	✓	✓	✓	—	—	–40 to +85	SSOP5	✓	—	—	BUxxTD3WG
—	✓	✓	✓	—	—	–40 to +85	SSON004X1010	✓	—	—	BUxxTD2WNVX
—	✓	✓	✓	—	—	–40 to +85	SSON004X1216	✓	—	—	BUxxTA2WNVX
—	✓	✓	✓	—	—	–40 to +85	HVSOF5	✓	—	—	BUxxTA2WHFV
—	—	✓	✓	—	—	–40 to +85	UCSP50L1 (0.8×0.8×0.55)	✓	—	—	BUxxSA4WGWL
—	—	✓	✓	—	AEC-Q100	–40 to +105	SSOP5	—	—	✓	BUxxSD2MG-M
—	✓	✓	✓	—	AEC-Q100	–40 to +125	SSON004R1010	—	—	✓	BUxxJA2MNVX-C
—	—	✓	✓	—	AEC-Q100	–40 to +125	SSOP5	—	—	✓	BUxxJA2VG-C
—	✓	✓	✓	—	AEC-Q100	–40 to +125	SSOP5	—	—	✓	BUxxJA2DG-C
—	—	✓	✓	—	—	–40 to +85	HVSOF5	✓	—	—	BUxxNB1WHFV
✓	✓	✓	✓	—	Light load mode	–40 to +85	HVSOF5	✓	—	—	BUxxPB1WHFV
—	—	✓	✓	—	—	–40 to +85	VCSP60N1 (0.96×0.96×0.675)	✓	—	—	BUxxSA3WGUT
—	—	✓	✓	—	—	–40 to +85	VCSP60N1 (1.04×1.0×0.675)	✓	—	—	BUxxRB1WGUT

Single Output LDO-Type Linear Regulator Selection Charts

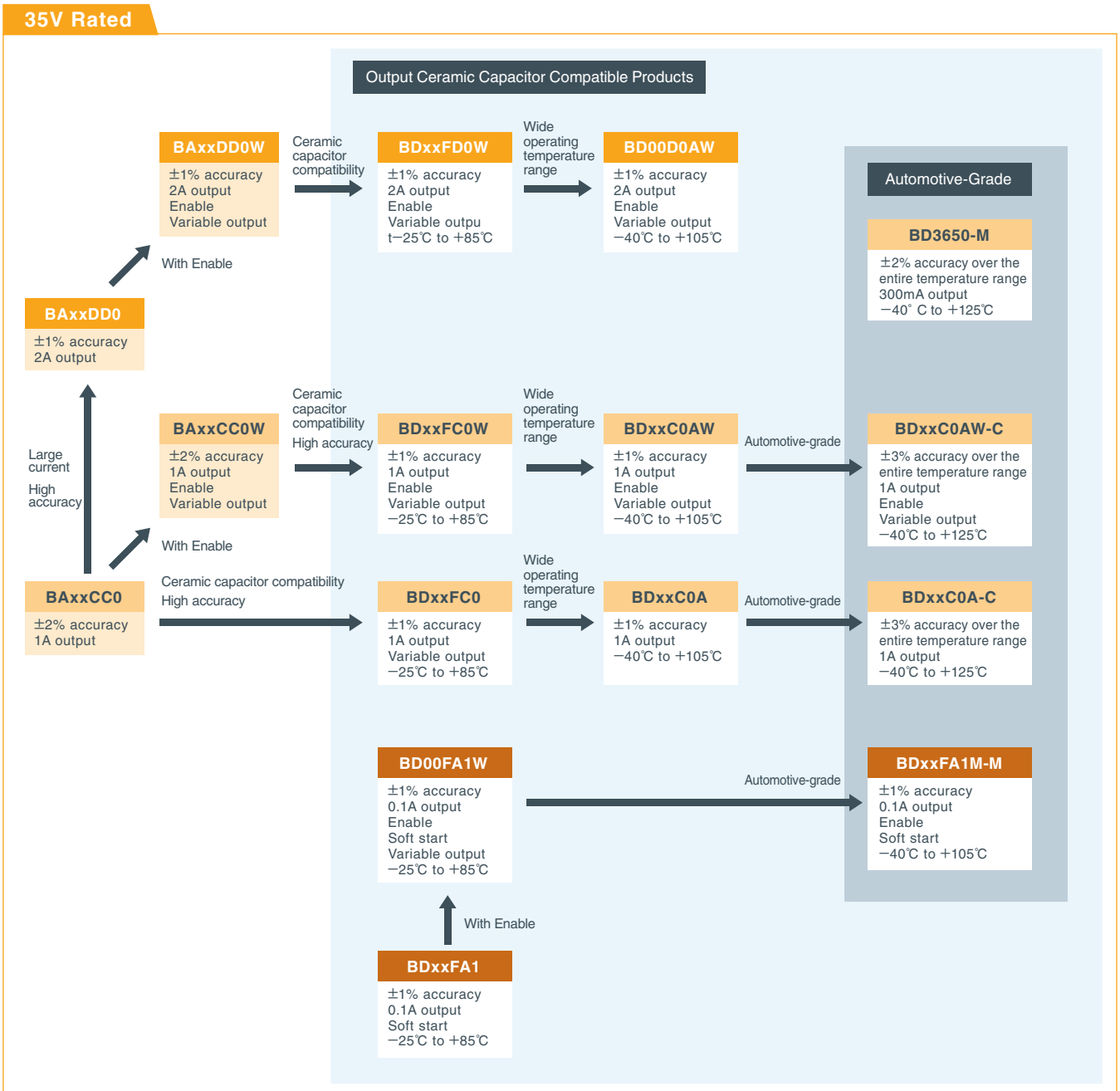
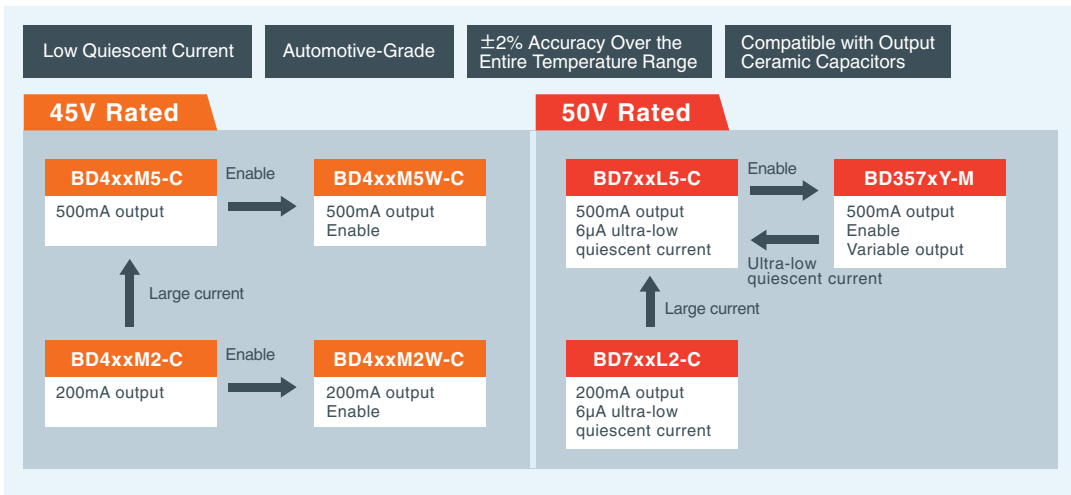

18V Rated

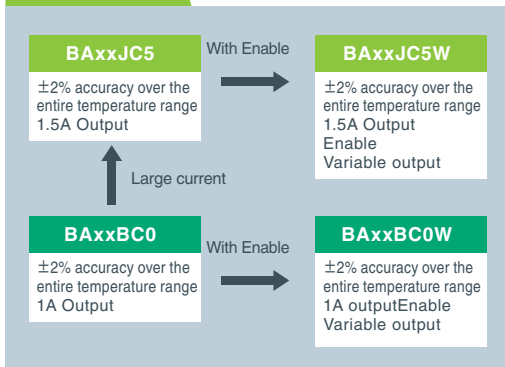

15V Rated 10V Rated 7V Rated

Output Ceramic Capacitor Compatible Products

±1% accuracy

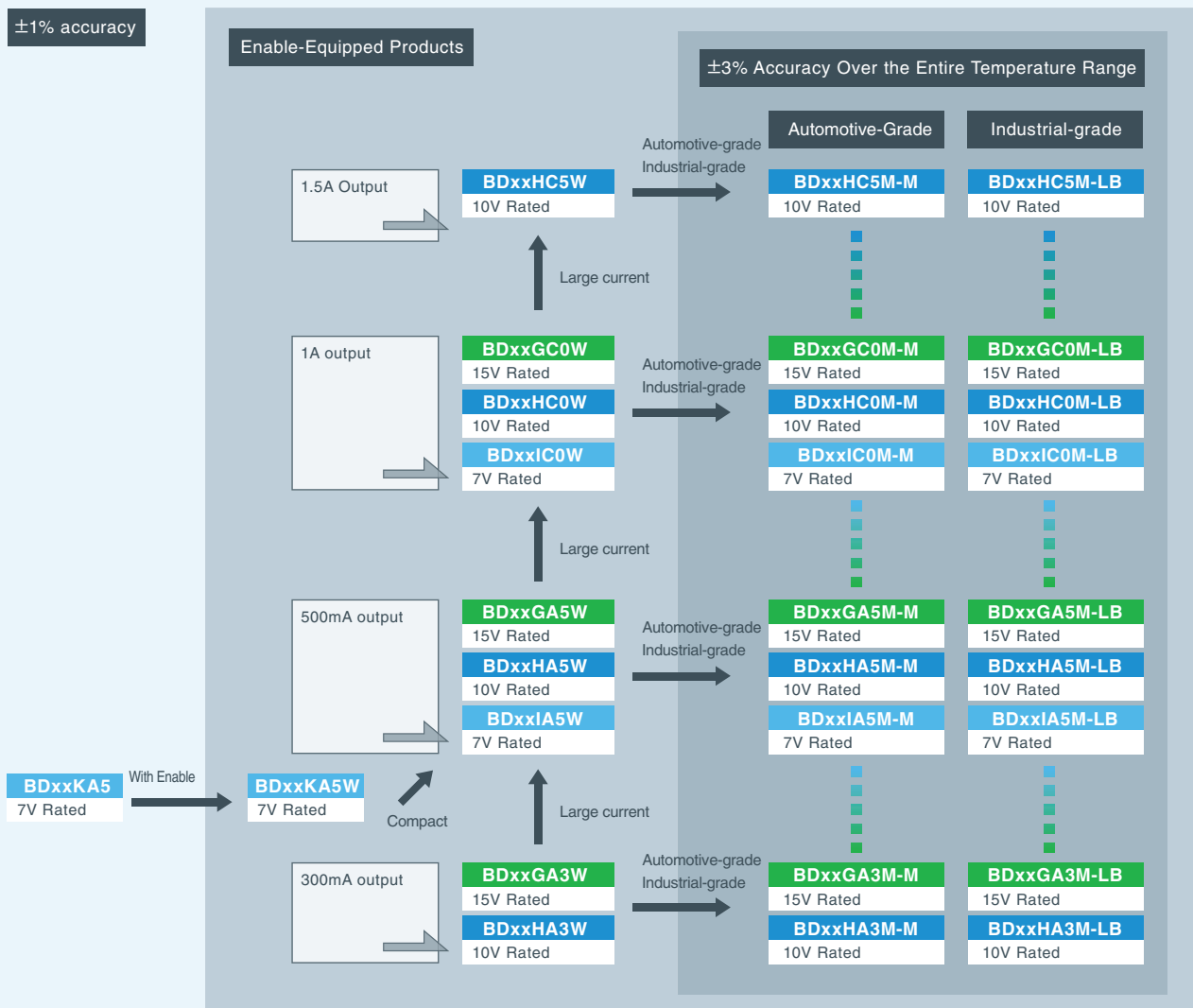

Single Output LDO-Type Linear Regulator Selection Charts

5.5 to 6.5V Rated

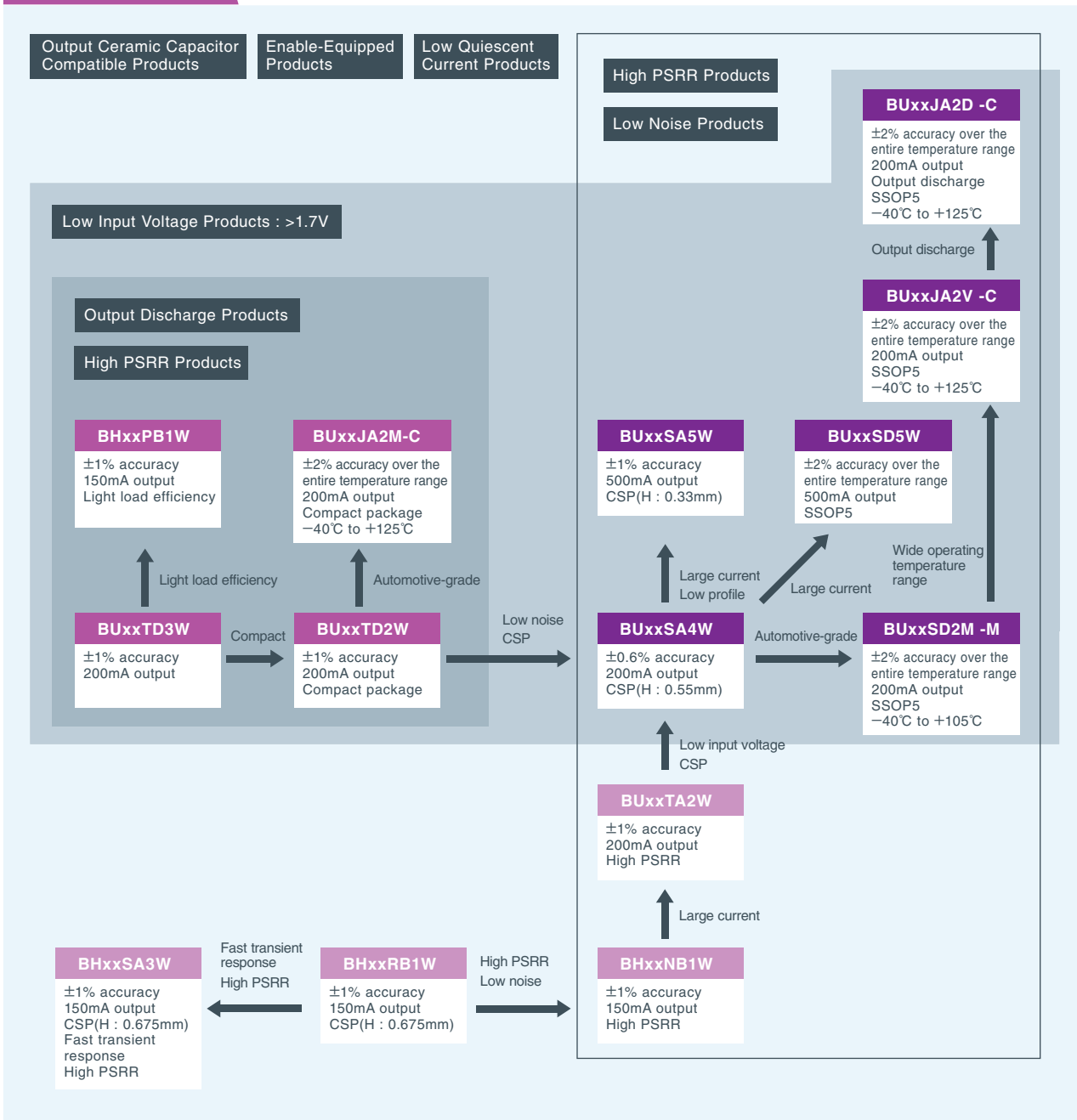

Single Output Ultra-Low LDO-Type Linear Regulators

Low Power Supply Solutions

This series of ultra-low LDO-type linear regulators with built-in low ON resistance transistors provides the optimum solution for power supply systems requiring multiple low voltages, such as those using digital signal processing ICs. Ultra-low-LDO-type linear regulators deliver superior low input-output voltage characteristics and low input voltage operation while achieving efficiency comparable to that of switching regulators. This makes it possible to reduce the number of external parts, including the inductor.

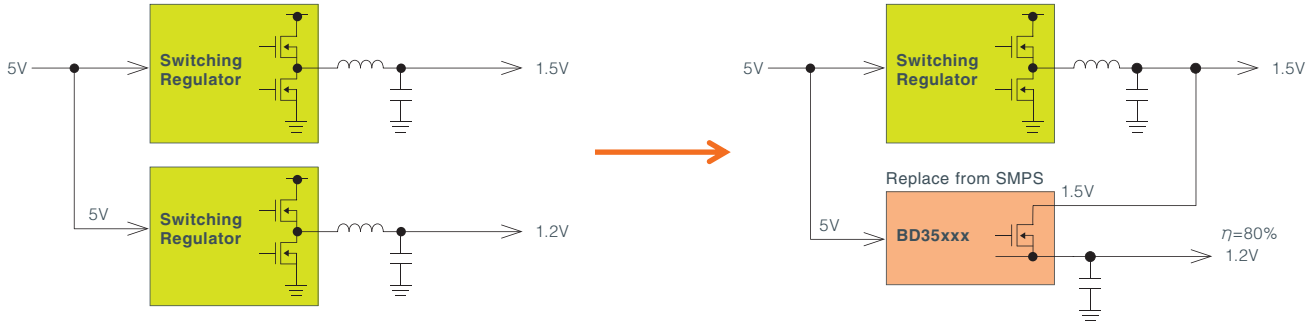

Product Example

BD3512MUV

- Input voltage : 0.7V to $(V_{CC}-1)V$
- Output voltage : 0.65V to 2.7V
- Output current : 3A
- High accuracy reference voltage circuit : $0.65V \pm 1\%$
- Nch power MOSFET ON resistance : $65m\Omega$
- Minimal input-output voltage difference : $100mV \text{ Max}(I_o=1A, V_{IN}=1.2V)$
- Soft start prevents inrush current during power ON
- Power Good output with adjustable delay setting
- Enable function
- Under Voltage Lock Out circuit(UVLO)
- Thermal Shutdown circuit(TSD)
- Overcurrent Protection circuit(OCP)

Ultra-Low LDO-Type Linear Regulator

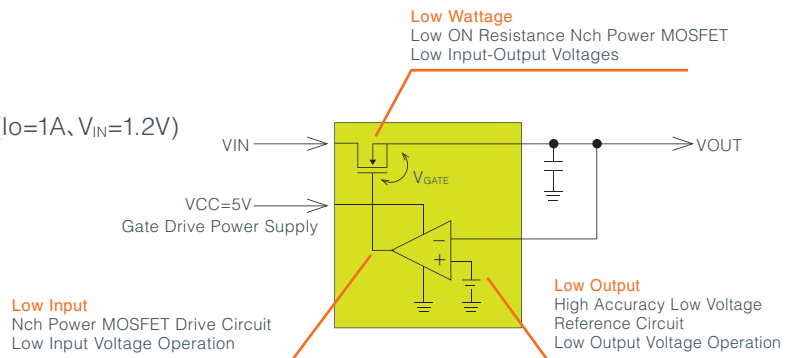

Part No.	Output Current (A)	Input Voltage(V)		Output Voltage (V)	Voltage Accuracy (%)	Input-Output Voltage Difference(mV) $I_o=0.1A$	Power Good	Variable Soft Start	UVLO	OCP	TSD	Operating Temperature T_a (°C)	Package
		V_{CC}	V_{IN}										
BD3550HFN	0.5	4.3 to 5.5	$0.95 \text{ to } (V_{CC}-1)$	0.65 to 2.7	±1	40	—	✓	✓	Recovery	Recovery	-10 to +100	HSO8
BD3507HFV	0.55	4.5 to 5.5	$1.2 \text{ to } (V_{CC}-1)$	0.65 to 2.7		HVSOF6							
BD3551HFN	1.0	4.3 to 5.5	$0.95 \text{ to } (V_{CC}-1)$	0.65 to 2.7		HSO8							
BD3506F	2.5	4.3 to 5.5	$1.2 \text{ to } (V_{CC}-1)$	0.65 to 2.5		SOP8							
BD3552HFN	2.0	4.3 to 5.5	$0.95 \text{ to } (V_{CC}-1)$	0.65 to 2.7		HSO8							
BD3508MUV	3.0	4.3 to 5.5	$0.75 \text{ to } (V_{CC}-1)$	0.65 to 2.7		VQFN020V4040							
BD3540NUV	0.5	3.0 to 5.5	$0.95 \text{ to } (V_{CC}-1)$	0.65 to 2.7	±1	40	✓	✓	Recovery	Recovery	-10 to +100	VSON010V3030	
BD3541NUV	1.0	3.0 to 5.5	$0.95 \text{ to } (V_{CC}-1)$	0.65 to 2.7		Recovery				VSON010V3030			
BD3512MUV	3.0	4.3 to 5.5	$0.7 \text{ to } (V_{CC}-1)$	0.65 to 2.7		Latch				VQFN020V4040			
BD3509MUV	4.0	4.3 to 5.5	$0.7 \text{ to } (V_{CC}-1)$	0.65 to 2.7		Recovery				VQFN020V4040			
BD3504FVM	External FET	4.5 to 5.5	$V_o + (I_o \times R_o) \text{ to } (V_{CC}-1)$	0.65 to 2.5		—				—		✓	✓
BD3521FVM	External FET	4.5 to 5.5	$V_o + (I_o \times R_o) \text{ to } (V_{CC}-1)$	1.5	—	—	✓	✓	SCP Latch	Latch	-10 to +100	MSOP8	

UVLO : Under Voltage Lock Out

OCP : Overcurrent Protection

TSD : Thermal Protection

Multi-Output LDOs

Part No.	No. of Outputs	Rated Input (V)	ch	Output Current (A)	Input Voltage (V)	Output Voltage (V)	Output Voltage Accuracy (%)	V _{REF} (V)	Current Consumption	Functions						Other Features	Operating Temperature T _a (°C)	Package (mm)
										Enable	Output Ceramic Capacitor Compatibility	Output Discharge	UVLO	Overcurrent Protection	Thermal Shutdown			
BA30E00WHFP	2	18	1	0.6	4.1 to 16	3.3	±2	—	0.7mA	✓	—	—	—	✓	✓	—	-25 to +105	HRP7
			2	0.6	2.8 to V _{in} -1	Variable 0.8 to 3.3	±2	0.8		—	—	—	✓	✓				
BA3259HFP	2	15	1	1.0	4.75 to 14	3.3	±2	—	3mA	—	✓	—	—	✓	✓	—	0 to +85	HRP5
			2	1.0		Variable 0.8 to 3.3	±2	0.8		—	—	✓	✓					
BA33D15HFP	2	18	1	0.5	4.1 to 16	3.3	±2	—	0.7mA	—	✓	—	—	✓	✓	—	-25 to +105	HRP5
			2	0.5		1.5	±2	—		—	✓	✓						
BA33D18HFP	2	18	1	0.5	4.1 to 16	3.3	±2	—	0.7mA	—	✓	—	—	✓	✓	—	-25 to +105	HRP5
			2	0.5		1.8	±2	—		—	✓	✓						
BD7003NUX	2	7	1	0.3	2.5 to 5.5	1.5/1.8/2.6/2.8/2.9	±1.8	—	55µA	✓	✓	✓	✓	✓	✓	Programmable output	-40 to +85	VSON008X2020
			2	0.3		2.7/2.8/2.9/3.3	±1.8	—		—	✓	✓	✓	✓				
BD7004NUX	2	7	1	0.3	2.5 to 5.5	1.2/1.8/2.8/3.0/3.3	±1.8	—	55µA	✓	✓	✓	✓	✓	✓	Programmable output	-40 to +85	VSON008X2020
			2	0.3		1.5/1.8/3.0/3.3	±1.8	—		—	✓	✓	✓	✓				
BD7602GUL	2	7	1	0.1	2.7 to 5.5	3	±2	—	10µA	✓	✓	✓	✓	—	✓	I ² C control GPO	-35 to +85	VCSP50L1C (1.6×1.6×0.57)
			2	0.15		Variable 0.8 to 3.3	±2	—		—	✓	✓	✓	✓				
BU6650NUX	3	6	1	0.2	2.5 to 5.5	2.8	±1	—	120µA	✓	✓	✓	—	✓	✓	—	-40 to +85	VSON008X2030
			2	0.2		1.8	±25mV	—		—	✓	✓						
			2	0.2		1.8	±25mV	—		—	✓	✓						
BU6651NUX	3	6	1	0.2	2.5 to 5.5	2.8	±1	—	120µA	✓	✓	✓	—	✓	✓	—	-40 to +85	VSON008X2030
			2	0.2		1.5	±25mV	—		—	✓	✓						
BU6652NUX	3	6	1	0.2	2.5 to 5.5	2.8	±1	—	120µA	✓	✓	✓	—	✓	✓	—	-40 to +85	VSON008X2030
			2	0.2		1.5	±25mV	—		—	✓	✓						
BU6653NUX	3	6	1	0.2	2.5 to 5.5	2.8	±1	—	120µA	✓	✓	✓	—	✓	✓	—	-40 to +85	VSON008X2030
			2	0.2		1.8	±25mV	—		—	✓	✓						
			2	0.2		1.8	±25mV	—		—	✓	✓						
BU6654NUX	3	6	1	0.2	2.5 to 5.5	3.3	±1	—	120µA	✓	✓	✓	—	✓	✓	—	-40 to +85	VSON008X2030
			2	0.2		1.8	±25mV	—		—	✓	✓						
			2	0.2		1.5	±25mV	—		—	✓	✓						
BU6655NUX	3	6	1	0.2	2.5 to 5.5	3.3	±1	—	120µA	✓	✓	✓	—	✓	✓	—	-40 to +85	VSON008X2030
			2	0.2		2.8	±1	—		—	✓	✓						
			2	0.2		1.8	±25mV	—										

Hi-Fi Audio Power Supplies

Audio Power Supply Solutions

The BD372xx series consists of the industry's first high fidelity power supply ICs developed by combining proprietary audio quality design technology with power supply IC analog design expertise that leverages original power processes. In addition to a newly developed fast response error amp circuit and low noise architecture, ROHM optimized parameters shown to have an effect on sound quality during the development and production processes through listening evaluations to achieve class-leading performance in all of the critical characteristics (voltage stability, noise level, dual power supply symmetry) required for the power supplies of audio equipment. As a result, in the high fidelity audio sector that demands higher quality, extremely clean power is supplied compared to conventional ICs, making it possible to improve the sound quality of audio equipment in terms of sound imaging (sound source position, sense of distance) and resolution (realism and depth) from the power supply line.

Power Supply Characteristics Required by Hi-Fi Audio

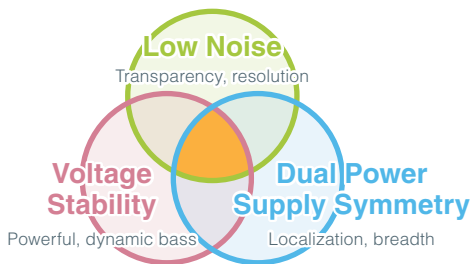

It is important to balance 3 parameters

Sound Quality Comparison Through Auditory Evaluation

*ROHM October 2018 study

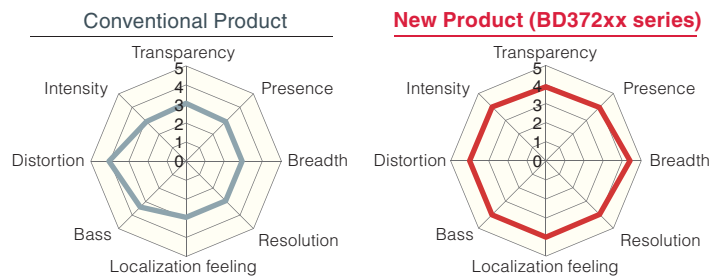

The BD372xx series delivers less noise while achieving greater realism and depth, allowing listeners to feel the an immersive sound stage (i.e. drum beats, applause).

Features

As the industry's first high fidelity audio power supply IC, the BD372xx series includes the following features.

1. Clean power supply improves sound quality in audio equipment.

1) Increases audio quality through voltage stabilization

An integrated newly developed error amp circuit capable of fast response over a wide range minimizes the effects of input voltage and output current fluctuations on the output voltage. The result is superior sound quality that does not ignore the dynamic bass and intensity present in audio sources.

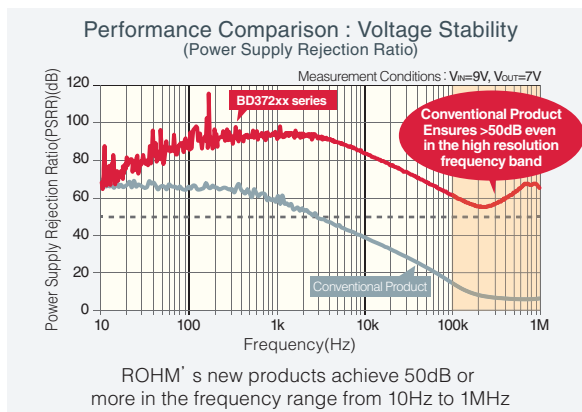

2) Improves audio quality by minimizing noise

Adopting a low noise architecture that suppresses noise generated from the IC's internal circuit makes it possible to achieve a class-leading low noise of just 4.6µVrms, 50x smaller than conventional products. This eliminates the effects of noise on the sound, resulting in clear audio with exceptional transparency.

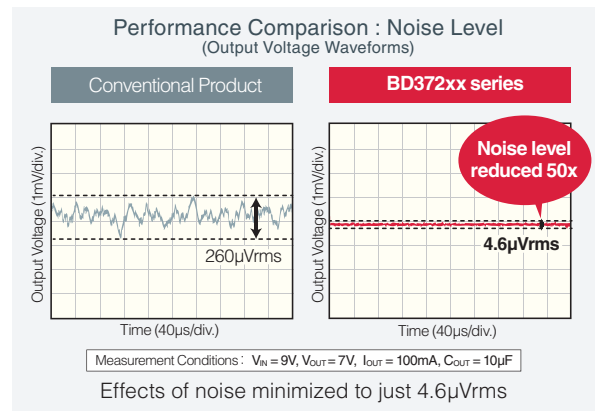

3) Improves sound quality through dual power supply symmetry

Not only the positive power supply, but the negative supply as well featuring the same circuit configuration are simultaneously lined up, achieving a power supply with ideal symmetry in terms of characteristics when used together. As a result it is possible to clarify the localization of the sound image and expand the sound stage.

2. Broad lineup meets the needs of high fidelity audio

The BD37201NUX is optimized for digital devices that operate at low voltages (i.e. DACs, DSPs). Meanwhile, the BD37210MUV (positive power supply) and BD37215MUV (negative power supply) are suitable for analog applications requiring high voltage or dual (+/-) power supply operation such as sound processors and current-voltage conversion amps, contributing to increased sound quality in audio devices.

	BD37201NUX	BD37210MUV	BD37215MUV
Type	Low voltage input Compact package	High voltage input Positive voltage	High voltage input Negative voltage
Input Voltage	2.7V to 5.5V	3.0V to 16V	-16V to -3.3V
Output Voltage	1.0V to 4.5V	1.0V to 15V	-15V to -1.0V
Output Current	500mA	1A	-1A
Noise Level(10Hz to 100kHz)	4.72 μ Vrms	4.6 μ Vrms	5.1 μ Vrms
PSRR(1kHz)	90dB	78dB	90dB
PSRR(10Hz to 1MHz)	\geq 50dB	\geq 50dB	\geq 50dB
Package(mm)	VSON008X2030 2.0X3.0	VQFN020V4040 4.0X4.0	VQFN020V4040 4.0X4.0

Portable Amp Configuration Example

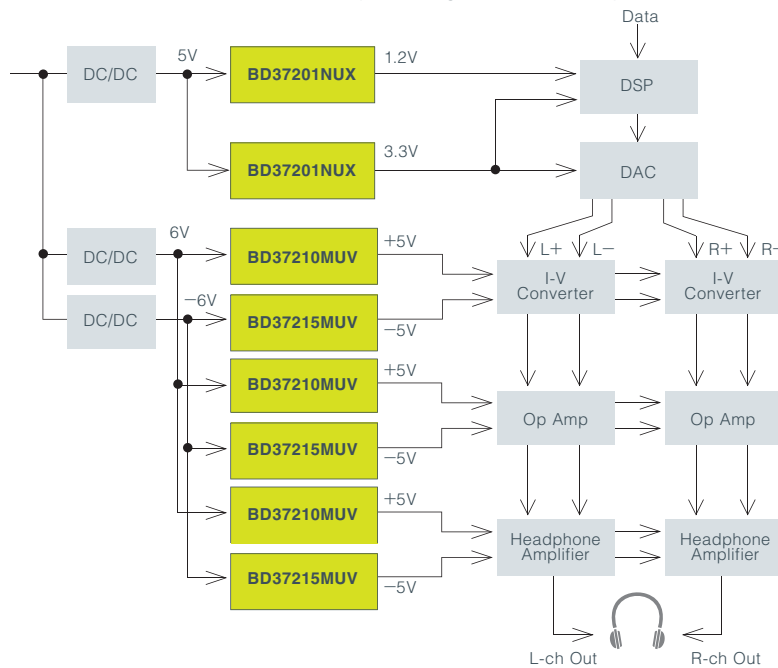

BD37201NUX Noise Voltage Characteristics

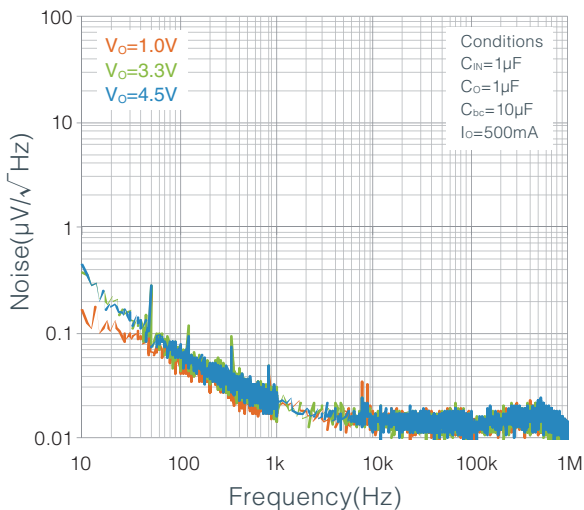

BD37201NUX Application Circuit Diagram

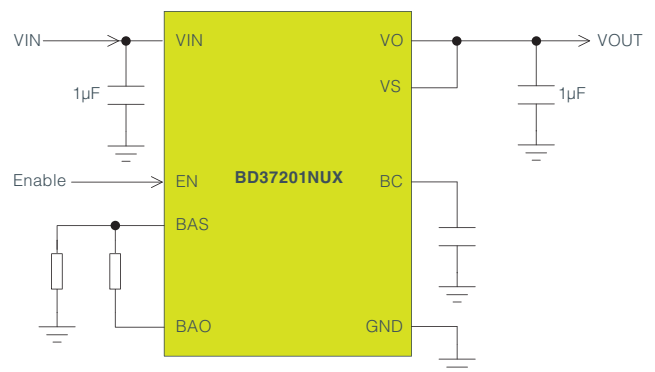

LDO+(Plus)

The BD4269FJ, BD4269EFJ, and BD4275 with built-in voltage detection function are ideal for abnormal voltage monitoring. At the same time, the BD4271, BD3020HFP, and BD3021HFP equipped with a watchdog timer and voltage detection circuit support the detection of abnormal voltages and MCU malfunctions.

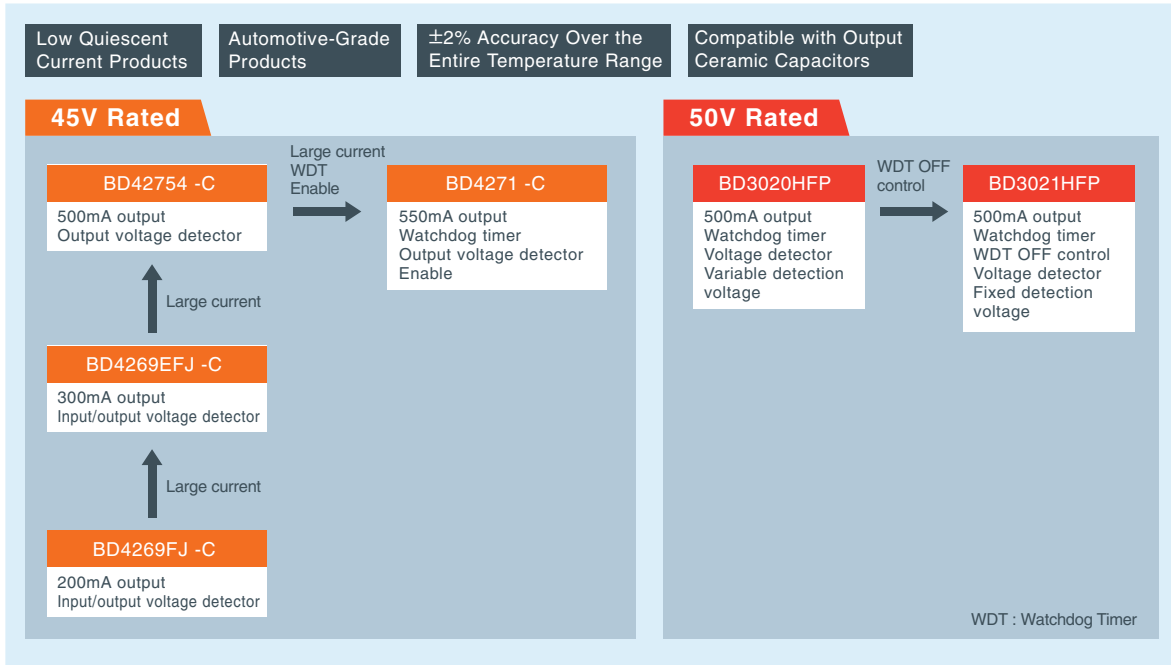

Part No.	Rated Input (V)	Output Current (A)	Input Voltage (V)	Output Voltage (V)	Output Voltage Accuracy (%)	V _{REF} (V)	Current Consumption (μA)	Functions					Other Features	Operating Temperature T _a (°C)	Package	
								Enable	Output Ceramic Capacitor Compatibility	Watchdog Timer	Voltage Detector	Overcurrent Protection				Thermal Shutdown
BD3020HFP	50	0.5	5.6 to 36	5.0	±2 ^{*1}	—	80	—	✓	✓	Variable	✓	✓	—	-40 to +125	HRP7
BD3021HFP	50	0.5	5.6 to 36	5.0	±2 ^{*1}	—	80	—	✓	✓	Fixed	✓	✓	WDT ^{*2} OFF Control	-40 to +125	HRP7
BD4271HFP-C/ BD4271FP2-C	45	0.55	6.0 to 45	5.0	±2 ^{*1}	—	75	✓	✓	✓	Fixed	✓	✓	AEC-Q100	T _j -40 to +150	HRP7/ TO263-7
BD42754-C	45	0.5	5.5 to 45	5.0	±2 ^{*1}	—	75	—	✓	—	Fixed	✓	✓	AEC-Q100	T _j -40 to +150	TO252-J5/ TO263-5
BD4269EFJ-C/ BD4269FJ-C	45	0.3 0.2	6.0 to 45	5.0	±2 ^{*1}	—	70	—	✓	—	Variable	✓	✓	AEC-Q100	T _j -40 to +150	HTSOP-J8/ SOP-J8

*1 : Accuracy over the entire temperature range

*2 : Watchdog timer

MCU Monitoring Power Supply Solution

The BD4271HFP-C and BD4271FP2-C are AEC-Q100 qualified 45V rated 550mA output regulators that integrate a power supply voltage monitoring reset circuit and watchdog timer (WDT) capable of detecting MCU malfunctions on a single chip.

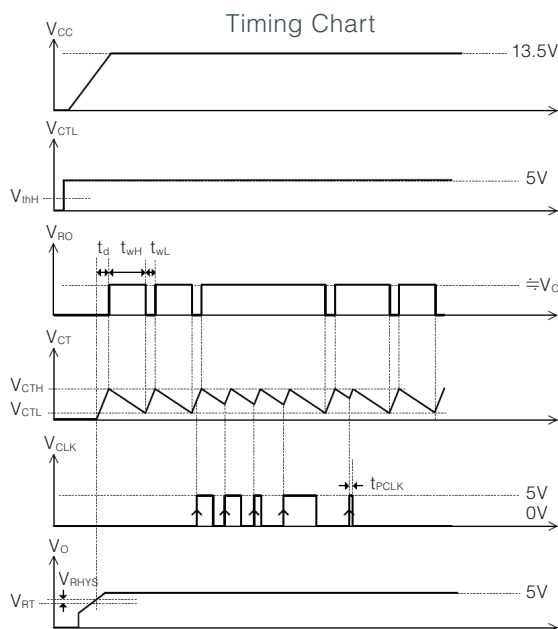
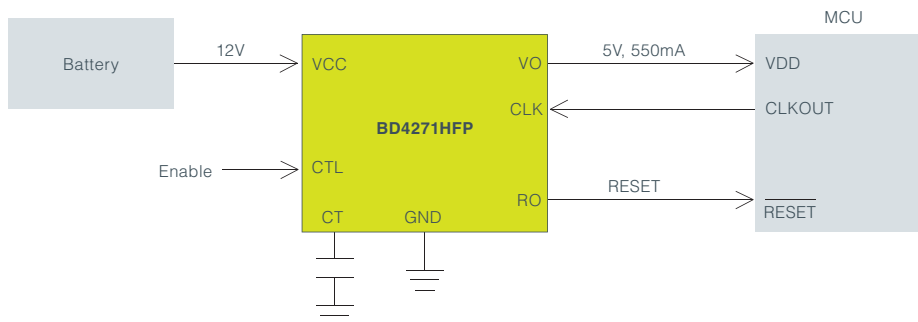

Product Example

BD4271HFP-C/BD4271FP2-C

- Ultra-low quiescent current : 75 μ A(Typ)
- Output transistor : Pch DMOS low saturation type
- Max. rated voltage : 45V
- Output current : 550mA
- Output voltage : 5.0V \pm 2%(over entire temp. range)
- Supports low ESR ceramic capacitors for output phase compensation
- Built-in watchdog timer detects MCU hangups and performs reset to enable system restart
- Enables adjustment of the watchdog monitoring time using an external capacitor
- Integrated output low voltage reset circuit (power ON reset) enables adjustable startup delay time setting
- Output ON/OFF control possible using the CTL pin
- Built-in overcurrent protection circuit prevents IC damage (i.e. due to output shorts)
- Integrated thermal shutdown circuit prevents IC damage (i.e. due to overload conditions)

BD4271HFP-C
HRP7

9.395mm \times 10.54mm \times 2.005mm



BD4271FP2-C
TO263-7

10.16mm \times 15.10mm \times 4.70mm



Power Supply Monitoring Solutions

The BD4269FJ-C, BD4269EFJ-C, BD42754FP2-C, and BD42754FPJ-C are AEC-Q100 qualified 45V rated 200mA to 500mA output regulators that integrate a power supply voltage monitoring reset circuit on a single chip.

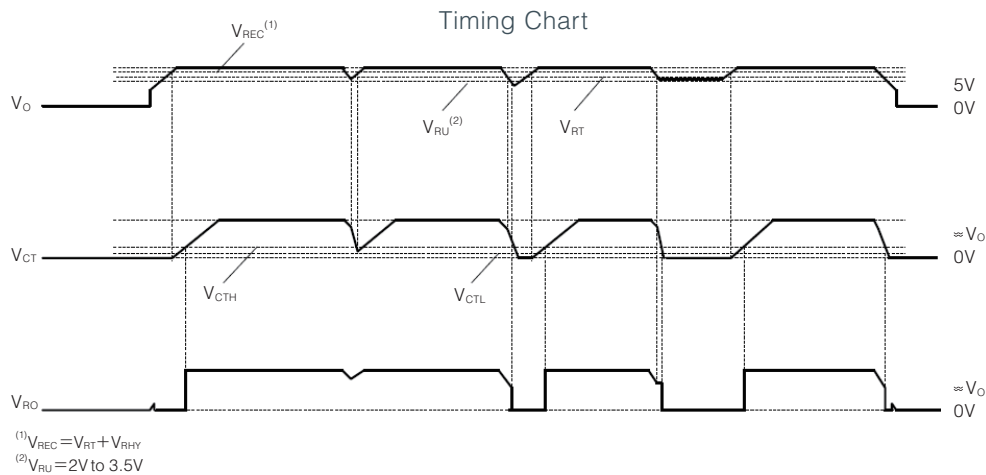
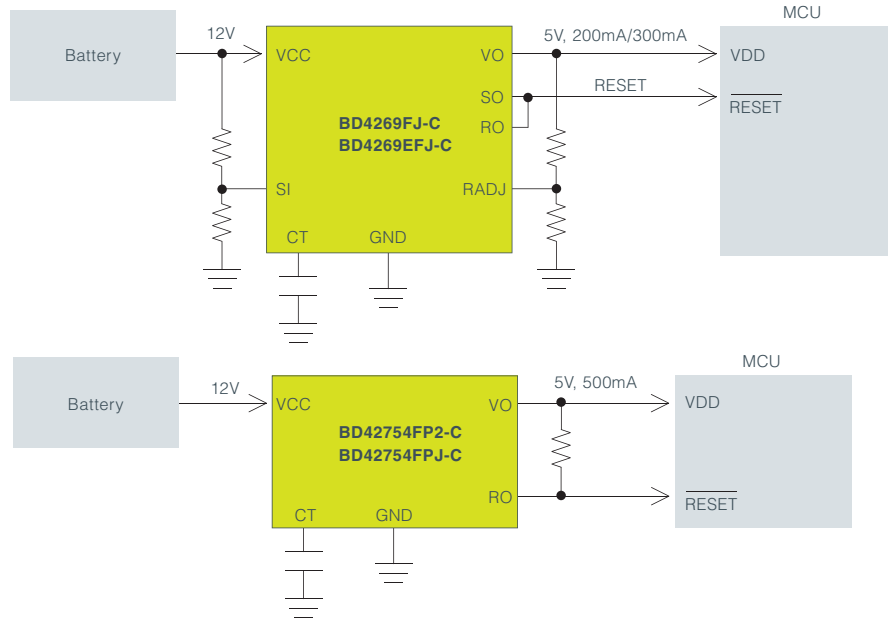

Product Example **BD4269FJ-C/BD4269EFJ-C/BD42754FP2-C/BD42754FPJ-C**

- Ultra-low quiescent current : 70 μ A(BD4269)/65 μ A(BD4275)
- Output transistor : Pch DMOS low saturation type
- Max. rated voltage : 45V
- Output current : 200mA(BD4269FJ), 300mA(BD4269EFJ), 500mA(BD42754)
- Output voltage : 5.0V \pm 2%(over entire temp. range)
- Supports low ESR ceramic capacitors at the output
- Integrated output low voltage reset circuit(power ON reset) enables setting of startup delay time
- Built-in power supply voltage detection reset circuit makes it possible to monitor the input power supply voltage or voltage of other power supplies(BD4269)
- Enables adjustment of the detection voltage of the power supply voltage detection reset circuit and output low voltage reset via external resistance(BD4269)
- Internal output current limiter circuit prevents IC damage(i.e. due to output shorts)
- Thermal shutdown circuit incorporated to prevent thermal damage to the IC caused by overload conditions



BD4269FJ-C
Io=200mA
| SOP-J8



BD4269EFJ-C
Io=300mA
| HTSOP-J8



BD42754FP2-C
Io=500mA
| TO263-5



BD42754FPJ-C
Io=500mA
| TO252-J5

For the full lineup of power supply ICs, please visit ROHM's website.



















Technical materials and tools are available, including datasheets, application notes, reference circuits, evaluation boards, and Spice models.



Tech Web, a dedicated technical site for power supply ICs, provides technical information useful for designers seeking basic knowledge on power ICs along with seminar information.







Package List

Surface Mount Packages





Surface Mount Packages	External Image	Package Code	Size(mm) W(Typ)×D(Typ)×H(Max)
HTSOP-J8		EFJ	4.90×6.00×1.00
SOP-J8		FJ	4.90×6.00×1.65
SOP8		F	5.00×6.20×1.71
SSOP-B20		FV	6.50×6.40×1.45
SSON004X1010		NVX	1.00×1.00×0.60
SSON004R1010		NVX	1.00×1.00×0.60
SSON004X1216		NVX	1.20×1.60×0.60
HVSOF5		HFV	1.60×1.60×0.60
HVSOF6		HFV	1.60×3.00×0.75
VSON008X2030		NUX	2.00×3.00×0.60
VSON010V3030		NUV	3.00×3.00×1.00
VSON010X3030		NUX	3.00×3.00×0.60
VQFN020V4040		MUV	4.00×4.00×1.00
SSOP5(SOT-23-5*)		G	2.90×2.80×1.25
SOT89-3K		FP3	4.50×4.095×1.60
SOT223-4F		FP3	6.53×7.00×1.80
TO252-3		FP	6.50×9.50×2.50
TO252S-3		FPS	6.50×9.50×1.30
TO252-5		FP	6.50×9.50×2.50

*JEDEC code

Surface Mount Packages

Surface Mount Packages	External Image	Package Code	Size(mm) W(Typ)×D(Typ)×H(Max)
TO252-J5/ TO252-J5F		FPJ	6.60×10.10×2.38
TO263-3(F)		FP2	10.16×15.10×4.70
TO263-5(F)		FP2	10.16×15.10×4.70
TO263-7		FP2	10.16×15.10×4.70
HRP5		HFP	9.395×10.54×2.005
HRP7		HFP	9.395×10.54×2.005

Through-Hole Packages

Surface Mount Packages	External Image	Package Code	Size(mm) W(Typ)×D(Typ)×H(Max)
TO220CP-3		CP	10.00×20.81×4.60
TO220FP-3		T	10.00×30.50×4.60
TO220CP-V5		CP	10.00×20.12×4.60
TO220FP-5		T	10.00×30.50×4.60

Wafer Level Chip Scale Packages

Surface Mount Packages	External Image	Package Code	Size(mm) W(Typ)×D(Typ)×H(Max)
VCSP60N1 UCSP30L1 UCSP50L1	Please refer to the individual product datasheets	GUT GWZ GWL	Please refer to the individual product datasheets

- 1) The information contained in this document is current as of October 1st, 2018.
- 2) The information contained herein is subject to change without notice. Before you use our Products, please contact our sales representative (as listed below) and verify the latest specifications.
- 3) Although ROHM is continuously working to improve product reliability and quality, semiconductors can break down and malfunction due to various factors. Therefore, in order to prevent personal injury or fire arising from failure, please take safety measures such as complying with the derating characteristics, implementing redundant and fire prevention designs, and utilizing backups and fail-safe procedures. ROHM shall have no responsibility for any damages arising out of the use of our Products beyond the rating specified by ROHM.
- 4) Examples of application circuits, circuit constants and any other information contained herein are provided only to illustrate the standard usage and operations of the Products. The peripheral conditions must be taken into account when designing circuits for mass production.
- 5) The technical information specified herein is intended only to show the typical functions of and examples of application circuits for the Products. ROHM does not grant you, explicitly or implicitly, any license to use or exercise intellectual property or other rights held by ROHM or any other parties. ROHM shall have no responsibility whatsoever for any dispute arising out of the use of such technical information.
- 6) The Products are intended for use in general electronic equipment (i.e. AV/OA devices, communication, consumer systems, gaming/entertainment sets) as well as the applications indicated in this document.
- 7) The Products specified in this document are not designed to be radiation tolerant.
- 8) For use of our Products in applications requiring a high degree of reliability (as exemplified below), please contact and consult with a ROHM representative: transportation equipment (i.e. cars, ships, trains), primary communication equipment, traffic lights, fire/crime prevention, safety equipment, medical systems, servers, solar cells, and power transmission systems.
- 9) Do not use our Products in applications requiring extremely high reliability, such as aerospace equipment, nuclear power control systems, and submarine repeaters.
- 10) ROHM shall have no responsibility for any damages or injury arising from non-compliance with the recommended usage conditions and specifications contained herein.
- 11) ROHM has used reasonable care to ensure the accuracy of the information contained in this document. However, ROHM does not warrant that such information is error-free and ROHM shall have no responsibility for any damages arising from any inaccuracy or misprint of such information.
- 12) Please use the Products in accordance with any applicable environmental laws and regulations, such as the RoHS Directive. For more details, including RoHS compatibility, please contact a ROHM sales office as listed below. ROHM shall have no responsibility for any damages or losses resulting non-compliance with any applicable laws or regulations.
- 13) When providing our Products and technologies contained in this document to other countries, you must abide by the procedures and provisions stipulated in all applicable export laws and regulations, including without limitation the US Export Administration Regulations and the Foreign Exchange and Foreign Trade Act.
- 14) This document, in part or in whole, may not be reprinted or reproduced without prior consent of ROHM.

ROHM Sales Offices

Contact us for further information about the products.

Santa Clara	+1-408-720-1900	Stuttgart	+49-711-7272370	Dalian	+86-411-8230-8549	Malaysia	+60-3-7931-8155
Atlanta	+1-770-754-5972	Nuremberg	+49-911-810452-26	Beijing	+86-10-8525-2483	India	+91-80-4125-0811
Boston	+1-781-565-1138	France	+33 (0) 1 40 60 87 30	Shanghai	+86-21-6072-8612	Kyoto	+81-75-365-1077
Chicago	+1-847-368-1006	United Kingdom	+44-1-908-272400	Shenzhen	+86-755-8307-3008	Yokohama	+81-45-476-2121
Detroit	+1-248-348-9920	Finland	+358-400-726 124	Hong Kong	+852-2740-6262		
San Diego	+1-858-625-3600	Spain	+34-9375-24320	Taiwan	+886-2-2500-6956		
Mexico	+52-33-3123-2001	Hungary	+36-1-950-5859	Singapore	+65-6436-5100		
Brazil	+55-11-3539-6320	Italy	+39-039-5783432	Philippines	+63-2-807-6872		
Germany	+49-2154-921-0	Seoul	+82-2-8182-700	Thailand	+66-2-254-4890		

Catalog No.61P7170E 02.2019 ROHM © PDF

R1098A

ROHM Co., Ltd.

21 Saini Mizosaki-cho, Ukyo-ku,
Kyoto 615-8585 Japan

TEL : +81-75-311-2121 FAX : +81-75-315-0172

www.rohm.com

