



# ML22Q374/ML22Q374P

## ADPCM Speech Synthesis LSI

### ■ GENERAL DESCRIPTION

ML22Q374/ML22Q374P is voice synthesis LSI with built-in Flash memory that stores speech data. This LSI includes edit ROM, ADPCM2 decoder, low pass filter and D-class speaker amplifier. Also, ML22Q374/ML22Q374P support the synchronous serial interface.

By integrating all the functions required for voice output into a single chip, this LSI can be more easily incorporated in compact portable devices.

- Built-in memory capacity and maximum playback time:

Product name	ROM capacity	Maximum playback time (sec) (at $f_s=8.0\text{kHz}$ )	
		4bitADPCM2	16bitPCM
ML22Q374 ML22Q374P	692 Kbits	22.1	5.5

Notes: ROM capacity shows the numerical value of only a voice area.

- Voice synthesis method: 4-bit ADPCM2  
8-bit Nonlinear PCM  
8-bit PCM , 16-bit PCM  
Can be specified for each phrase.
- Speech ROM capacity ML22Q374/ML22Q374P: 692-Kbit Flash
- Sampling frequency( $F_s$ ): 6.4 / 8.0 / 10.7 / 12.8 / 16.0 / 21.3 / 25.6 / 32.0 kHz  
 $f_s$  can be specified for each phrase.
- Analog output: Built-in D-class amplifier
- CPU command interface: Synchronous serial interface
- Maximum number of phrases: 30 phrases
- Disconnection detection function /Speaker pin short detection function
- Source oscillation frequency: 4.096 MHz(internal)
- Power supply voltage: 2.0 to 5.5V
- Flash memory rewritable time: 80 times
- Operating temperature range: -40 to +85°C (ML22Q374)  
-40 to +105°C (ML22Q374P)
- AEC-Q100 Compliant
- Product name: 16-pin plastic SSOP  
ML22Q374-NNNMB, ML22Q374-xxxMB(xxx: ROM code No.)  
20-pin plasticTSSOP  
ML22Q374-NNNTD/ML22Q374-xxxTD  
ML22Q374P-NNNTD/ML22Q374P-xxxTD  
(xxx: ROM code No.)



The following table shows the differences among the ML22Q394.

Parameter	ML22Q374	ML22Q374P	ML22Q394	ML22Q394P
CPU interface	Synchronous serial interface	←	I <sup>2</sup> C	←
Memory capacity	692Kbit	←	←	←
Playback method	4-bit ADPCM2 8-bit nonlinear PCM 8-bit straight PCM 16-bit straight PCM	←	←	←
Maximum number of phrases	30	←	←	←
Sampling frequency (kHz)	6.4/12.8/25.6 8.0/16.0/32.0 10.7/21.3	←	←	←
Clock frequency	4.096MHz (internal oscillation)	←	←	←
Low-pass filter	FIR interpolation filter	←	←	←
Speaker driving amplifier	Built-in D-Class 1.0W (8Ω, SPV <sub>DD</sub> = 5 V)	Built-in D-Class 0.8W (8Ω, SPV <sub>DD</sub> = 5 V)	Built-in D-Class 1.0W (8Ω, SPV <sub>DD</sub> = 5 V)	Built-in D-Class 0.8W (8Ω, SPV <sub>DD</sub> = 5 V)
Edit ROM function	Yes	←	←	←
Volume control	32 levels	←	←	←
Silence insertion	Yes 20 ms to 1024 ms (4 ms/step)	←	←	←
Repeat function	Yes	←	←	←
Power supply voltage	2.0 V to 5.5 V	←	←	←
Operating temperature range	-40 to +85°C	-40 to +105°C	-40 to +85°C	-40 to +105°C
Package	16-pin SSOP	20-pin TSSOP	16-pin SSOP	20-pin TSSOP
	20-pin TSSOP		20-pin TSSOP	

■ BLOCK DIAGRAMs

ML22Q374-NNNMB/ML22Q374-xxxMB/ ML22Q374-NNNTD/ML22Q374-xxxTD  
 ML22Q374P-NNNTD/ML22Q374P-xxxTD

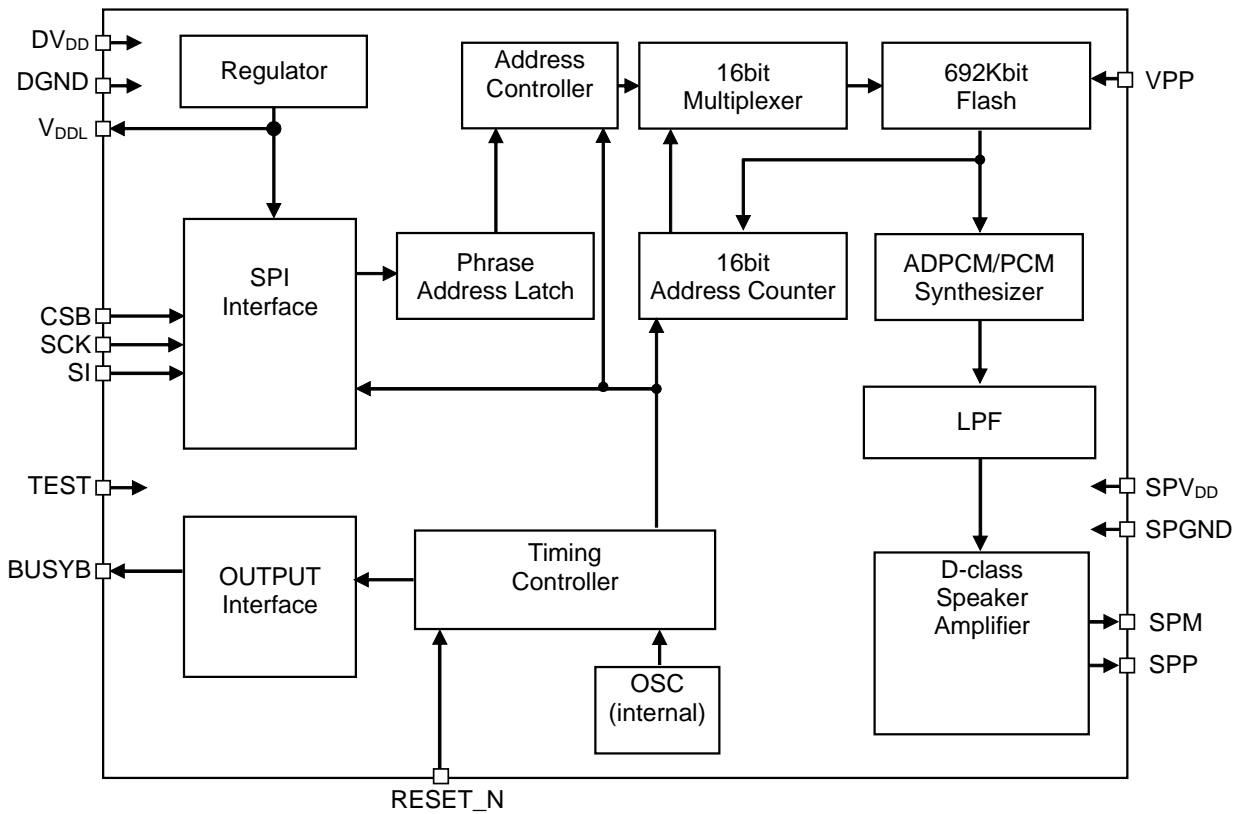

■ PIN CONFIGURATIONs (TOP VIEW)

ML22Q374-NNNMB/ML22Q374-xxxMB

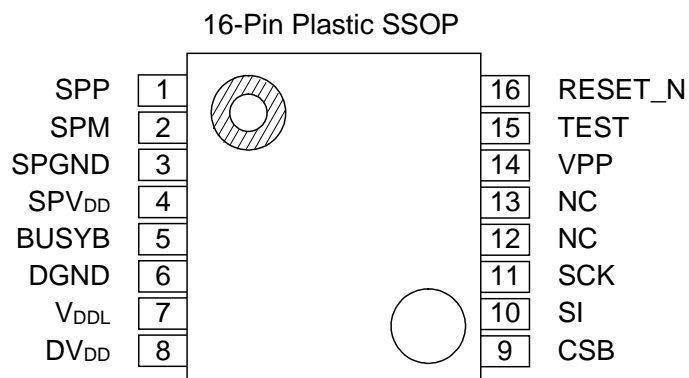

NC : Unused pin

ML22Q374-NNNTD/ML22Q374-xxxTD/ML22Q374P-NNNTD/ML22Q374P-xxxTD

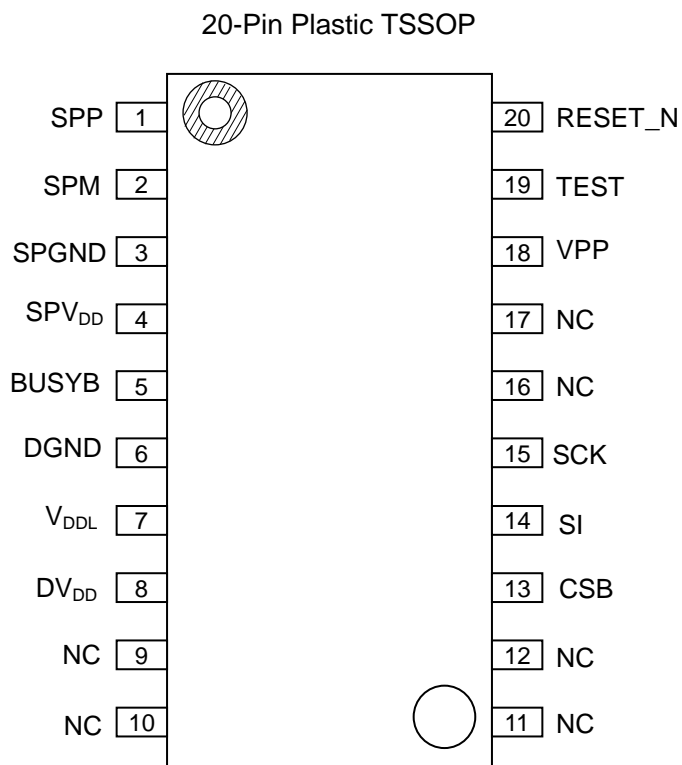

NC : Unused pin

## ■ PIN DESCRIPTION

Pin (20pin TSSOP)	Pin (16pin SSOP)	Symbol	I/O	Initial value (At the RESET_N Input)	Initial value (At standby)	Description
1	1	SPP	O	Hi-Z	Hi-Z	Positive(+) output pin of the speaker amplifier built-in
2	2	SPM	O	Hi-Z	Hi-Z	Negative(-) output pin of the speaker amplifier built-in.
3	3	SPGND	—	—	—	Ground pin for the speaker amplifier.
4	4	SPV <sub>DD</sub>	—	—	—	Power supply pin for the speaker amplifier. Connect a bypass capacitor of 1μF or more between this pin and SPGND pin.
5	5	BUSYB	O	Hi-Z	1	BUSY output pin. When BUSYB use mode is set, the "L" level is outputted during playback. At the time of a disconnection detection function, when disconnection is detected, the "L" level is outputted. Logical inversion can be set up with the Mask Option Setting screen of Speech Utility. In addition, when BUSYB use mode is not set, the initial value is outputted.
6	6	DGND	—	—	—	Digital ground pin.
7	7	V <sub>DDL</sub>	—	—	—	Regulator output pin for internal logic circuitry. Connect a capacitor of 10μF or more between this pin and DGND pin
8	8	DV <sub>DD</sub>	—	—	—	Power supply pins for logic circuitry. Connect a capacitor of 0.1μF or more between this pin and DGND pin.
13	9	CSB	I	1	1	Chip select pin, when CSB use mode is set. At the "L" level, data input is available. The pull-up resistor is built in.
14	10	SI	I	1	1	Input pin for the synchronous serial data.
15	11	SCK	I	1	1	Clock input pin for the synchronous serial interface.
18	14	VPP	—	—	—	Power supply pin for rewriting Flash memory. Fix this pin to DGND except when rewriting Flash memory.
19	15	TEST	I	0	0	Test pin. Fix this pin to a DGND level.
20	16	RESET_N	I	0	1	At the "L" level, the LSI enters initial state. After the power supply voltage is stable, drive this pin to "H" level.

## ■ ABSOLUTE MAXIMUM RATINGS

(DGND = SPGND = 0 V)

Parameter	Symbol	Condition	Rating	Unit
Power supply voltage	DV <sub>DD</sub>	Ta=25°C	-0.3 to +7.0	V
Speaker power supply voltage	SPV <sub>DD</sub>		-0.3 to +7.0	V
Internal logic power supply voltage	V <sub>DDL</sub>		-0.3 to +3.6	V
Flash power supply voltage	V <sub>PP</sub>		-0.3 to +9.5	V
Input voltage	V <sub>IN</sub>		-0.3 to DV <sub>DD</sub> +0.3	V
Power dissipation	P <sub>D</sub>		1	W
Output short-circuit current	I <sub>SC1</sub>	except SPP pin, SPM pin	-12 to +11	mA
	I <sub>SC2</sub>	SPP pin, SPM pin	300	mA
Storage temperature	T <sub>STG</sub>	—	-55 to +150	°C

## ■ RECOMMENDED OPERATING CONDITIONS

(DGND = SPGND = 0 V)

Parameter	Symbol	Condition	Range	Unit
Power supply voltage	DV <sub>DD</sub>	—	2.0 to 5.5	V
		Flash memory write	2.7 to 5.5	
Speaker power supply voltage	SPV <sub>DD</sub>	—	2.0 to 5.5	V
Flash power supply voltage	V <sub>PP</sub>	Flash memory write	7.7 to 8.3	V
Flash memory rewrite cycles	N	—	80	—
Operating temperature	T <sub>OP1</sub>	ML22Q374	-40 to +85	°C
		ML22Q374P	-40 to +105	
	T <sub>OP2</sub>	Flash memory write	0 to +40	

## ■ ELECTRICAL CHARACTERISTICS

### ● DC Characteristics

 $DV_{DD} = SPV_{DD} = 2.0 \text{ to } 5.5 \text{ V}, DGND = SPGND = 0 \text{ V}, Ta = -40 \text{ to } +85^\circ\text{C} \text{ (ML22Q374)}$ 
 $Ta = -40 \text{ to } +105^\circ\text{C} \text{ (ML22Q374P)}$ 

Parameter	Symbol	Condition	Min.	Typ.	Max.	Unit
"H" input voltage	$V_{IH}$	—	$0.7 \times DV_{DD}$	—	$DV_{DD}$	V
"L" input voltage	$V_{IL}$	—	0	—	$0.3 \times DV_{DD}$	V
"H" output voltage 1	$V_{OH1}$	$I_{OH} = -0.5 \text{ mA}$	$DV_{DD} - 0.5$	—	—	V
"L" output voltage 1	$V_{OL1}$	$I_{OL} = 0.5 \text{ mA}$	—	—	0.5	V
"H" input current 1	$I_{IH1}$	$V_{IH} = DV_{DD}$	—	—	1	$\mu\text{A}$
"H" input current 2	$I_{IH2}$	$V_{IH} = DV_{DD}$ TEST pin	0.02	0.3	1.5	mA
"L" input current 1	$I_{IL1}$	$V_{IL} = DGND$	-1	—	—	$\mu\text{A}$
"L" input current 2	$I_{IL2}$	$V_{IL} = DGND$ RESET_N, CSB pin	-1.5	-0.3	-0.02	mA
"H" output current 1	$I_{oOH1}$	$V_{OH} = DV_{DD} = SPV_{DD}$ (High impedance) BUSYB pin, SPP pin, SPM pin	—	—	1	$\mu\text{A}$
"H" output current 2	$I_{oOH2}$	$V_{OH} = DV_{DD}$ (Nch Open drain) BUSYB pin	—	—	1	$\mu\text{A}$
"L" output current 1	$I_{oOL1}$	$V_{OL} = DGND = SPGND$ (High impedance) BUSYB pin, SPP pin, SPM pin	-1	—	—	$\mu\text{A}$
"L" output current 1	$I_{oOL2}$	$V_{OL} = DGND$ (Pch Open drain) BUSYB pin	-1	—	—	$\mu\text{A}$
Supply current during playback	$I_{DD1}$	No output load, $DV_{DD} = 3.0\text{V}$	—	4.0	6.0	mA
	$I_{DD2}$	No output load, $DV_{DD} = 5.0\text{V}$	—	6.0	10	
Awaiting command supply current	$I_{DDC1}$	$DV_{DD} = SPV_{DD} = 5.0\text{V}$	—	3.0	5.0	mA
Standby supply current	$I_{DSS1}$	$Ta \leq +40^\circ\text{C}$	—	0.5	3.0	$\mu\text{A}$
	$I_{DSS2}$	$Ta \leq +85^\circ\text{C}$	—	0.5	8.0	
	$I_{DSS3}$	$Ta \leq +105^\circ\text{C}$	—	0.5	16.0	
Source oscillation frequency	$f_{OSC}$	$Ta = -10 \text{ to } +50^\circ\text{C}$	4.034	4.096	4.158	MHz
		$Ta = -40 \text{ to } +85^\circ\text{C}$	3.973	4.096	4.219	
		$Ta = -40 \text{ to } +105^\circ\text{C}$	3.973	4.096	4.219	

### ● Characteristics of Analog Circuitry

 $DV_{DD} = SPV_{DD} = 2.0 \text{ to } 5.5 \text{ V}, DGND = SPGND = 0 \text{ V}, Ta = -40 \text{ to } +85^\circ\text{C} \text{ (ML22Q374)}$ 
 $Ta = -40 \text{ to } +105^\circ\text{C} \text{ (ML22Q374P)}$ 

Parameter	Symbol	Condition	Min.	Typ.	Max.	Unit
SPM, SPP output load resistance	$R_{LSP}$	—	8	—	—	$\Omega$
Speaker amplifier output power	$P_{SPO}$	$SPV_{DD} = 5.0\text{V}$ , Sin wave $f = 1\text{kHz}$ $R_{LSP} = 8\Omega$ , THD $\geq 10\%$ (ML22Q374)	—	1.0	—	W
		$SPV_{DD} = 5.0\text{V}$ , Sin wave $f = 1\text{kHz}$ $R_{LSP} = 8\Omega$ , THD $\geq 10\%$ (ML22Q374P)	—	0.8	—	W

## ● AC Characteristics

DV<sub>DD</sub> = SPV<sub>DD</sub> = 2.0 to 5.5 V, DGND = SPGND = 0 V, Ta = -40 to +85°C (ML22Q374)

Ta = -40 to +105°C (ML22Q374P)

Parameter	Symbol	Condition	Min.	Typ.	Max.	Unit
RESET_N input pulse width	t <sub>RST</sub>	—	100	—	—	μs
Start time SPV <sub>DD</sub> after starting DV <sub>DD</sub>	t <sub>VDD</sub>	—	0	—	—	ns
Initialization time after reset release	t <sub>INIT</sub>	—	—	—	20	ms
BUSYB change time to "Hi-Z", after RESET_N fall edge	t <sub>BSYR</sub>	—	—	—	500	ns
SCK input enable time from CSB fall edge	t <sub>ESCK1</sub>	Oscillation stop	2	—	—	ms
	t <sub>ESCK2</sub>	Oscillating	10	—	—	μs
SCK hold time from CSB rise edge	t <sub>CSH</sub>	—	200	—	—	ns
Data setup time from SCK rise edge	t <sub>DIS</sub>	—	50	—	—	ns
Data hold time from SCK rise edge	t <sub>DIH</sub>	—	50	—	—	ns
SCK cycle	t <sub>SCYC</sub>	—	500	—	—	ns
SCK "H" level pulse width	t <sub>SCKH</sub>	—	200	—	—	ns
SCK "L" level pulse width	t <sub>SCKL</sub>	—	200	—	—	ns
Playback time	t <sub>VCYC</sub>	—	20	—	—	ms
BUSYB change time from "H" to "L", after a command is inputted	t <sub>CB</sub>	—	—	—	400	μs
CSB "H" level pulse width	t <sub>CSW</sub>	—	1	—	—	ms
Oscillation stop time, after playback	t <sub>OSST</sub>	—	—	—	500	μs
Next command transmit time In the case of the playback	t <sub>NCM</sub>	—	—	—	10	ms
Disconnection judging time by the DISCONNECT command	t <sub>DCCD</sub>	—	100	—	—	ms
BUSYB change time from "L" to "H", after Over-current detection of a speaker amplifier	t <sub>SD</sub>	—	—	—	80	μs
Processing time before playback start	t <sub>PLBF</sub>	—	0.3	—	2.1	ms
Processing time after playback start	t <sub>PLAF</sub>	—	0.15	—	1.2	ms
Fade-out time at Change Immediately mode or Change Immediately Once mode	t <sub>FDO</sub>	—	—	22	—	ms

Note: Output pin load capacitance = 45 pF



■ TIMING DIAGRAMS

● Power-On Timing

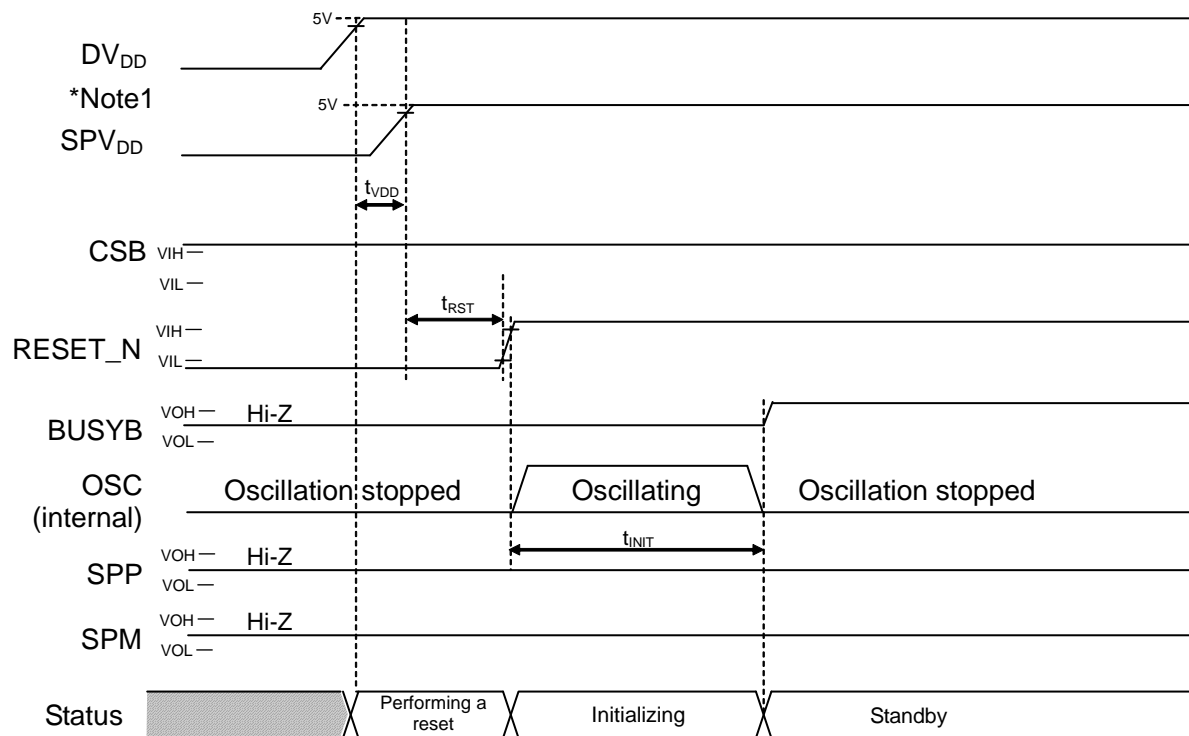

Note 1: Turn on DV<sub>DD</sub> and SPV<sub>DD</sub> simultaneously, or turn on SPV<sub>DD</sub> after turning on DV<sub>DD</sub>.

● Power-Down Timing (At the RESET\_N Input)

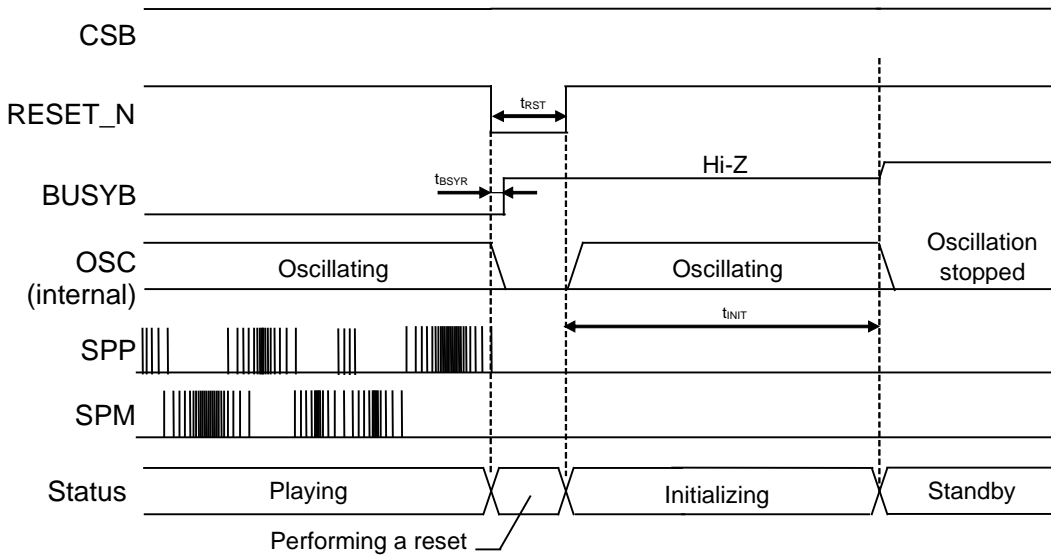

● Synchronous Serial Interface Timing

When "Normal("H"Level)" is chosen as mask option, the initial value of SCK is "H" level.

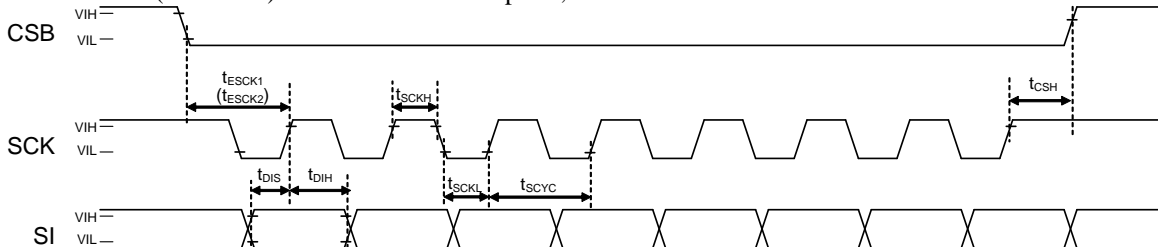

When "Reversal("L"Level)" is chosen as mask option, the initial value of SCK is "L" level.

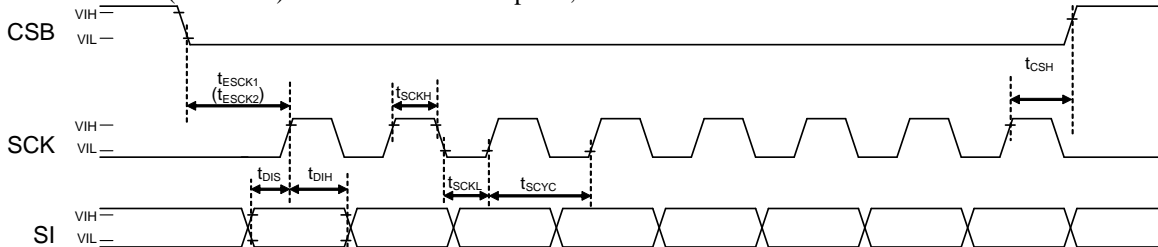

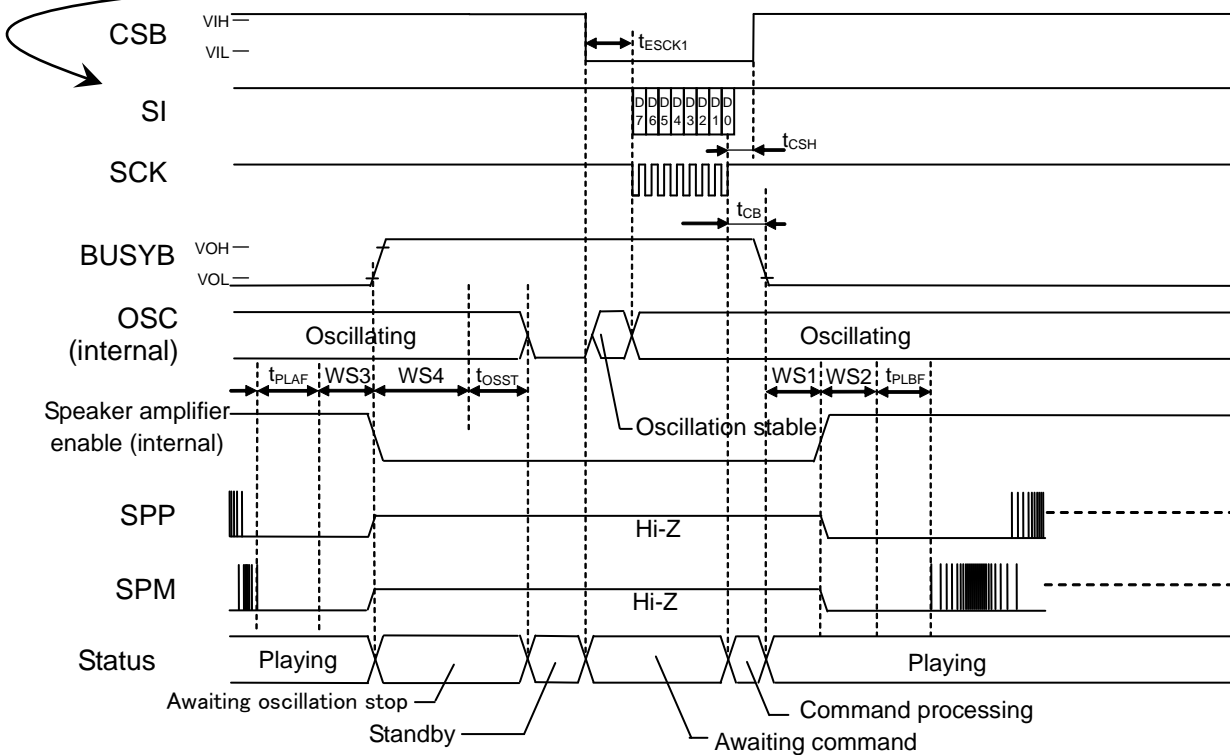
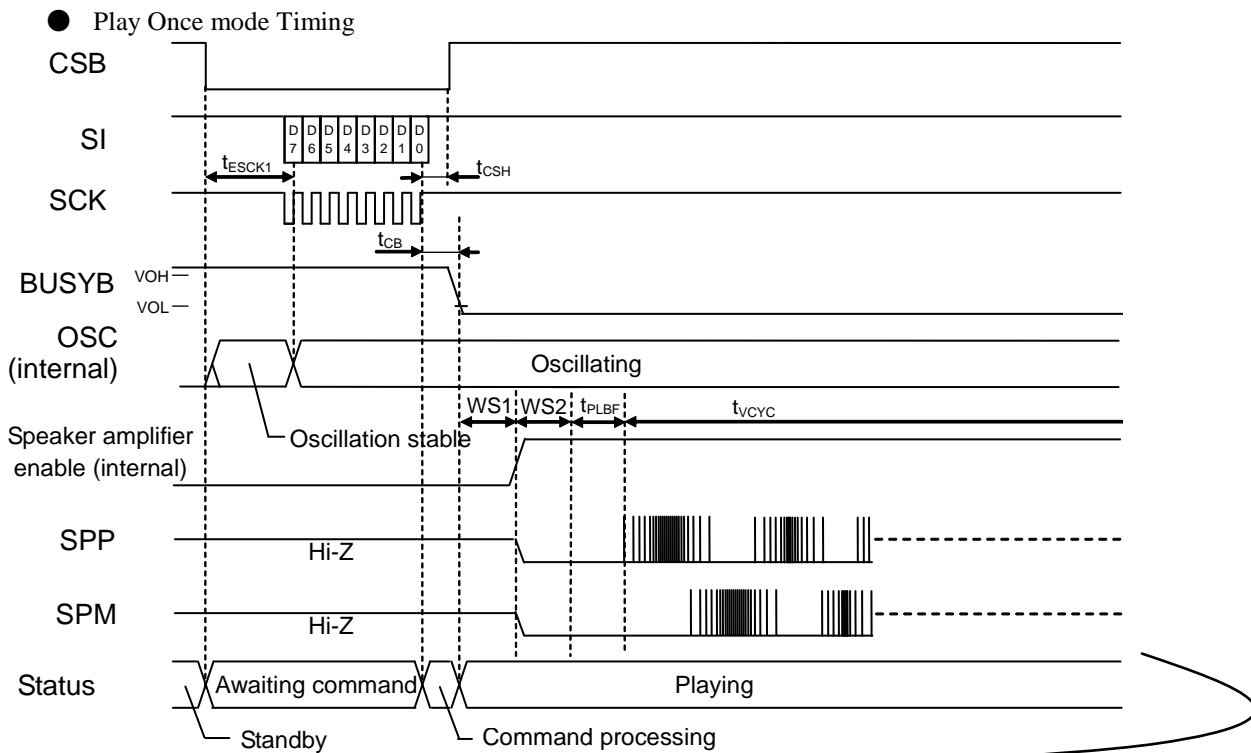

- The wait time of WS1, WS2, WS3, and WS4 can be set up for every phrase, when creating sound data using Speech LSI Utility.

- About this function, refer to “3. PHRASEn command” in “Description of Command Functions”

● Scheduled Play Once mode and Scheduled Play mode Timing (Continuous Play)

After inputting the next PHRASEn command(Phrase(n)), a phrase(Phrase(m)) is played back to the last and thePhrase(n) playback is started.

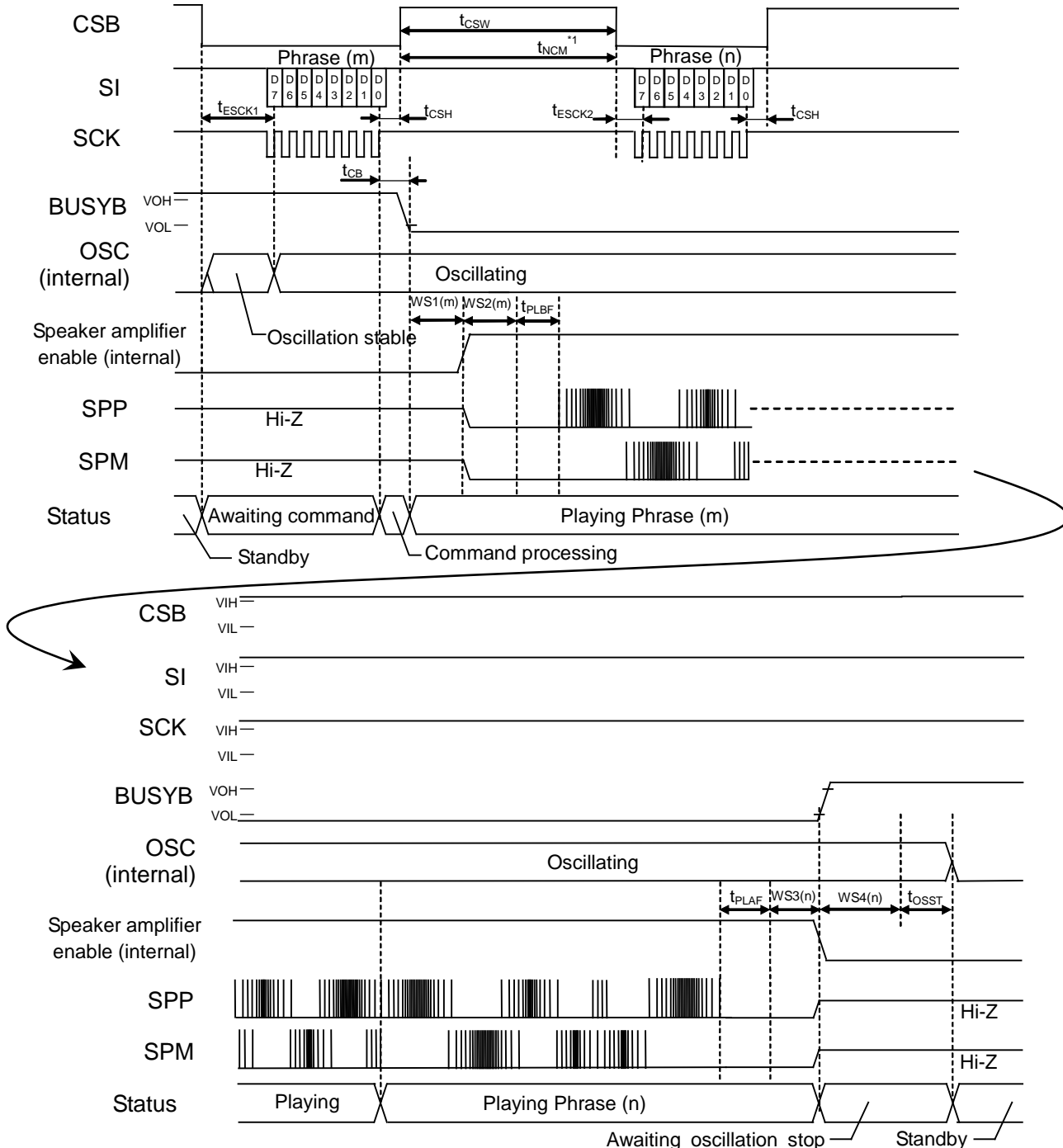

- The wait time of WS1, WS2, WS3, and WS4 can be set up for every phrase, when creating sound data using Speech Utility.
- About this function, refer to “3. PHRASEn command” in “Description of Command Functions”

\*1: It is applied to the Scheduled Play Once mode. Start the next PHRASEn command within the  $t_{NCM}$ . When it can't start, confirm the completion (BUSYB= "H") of the playback. Next, input the next command (PHRASEn command).

● Change Immediately Once mode and Change Immediately mode Timing (Continuous Play)

After inputting the next PHRASEn command(Phrase(n)), fade-out of the playback(Phrase(m)) is carried out and thePhrase(n) playback is started.

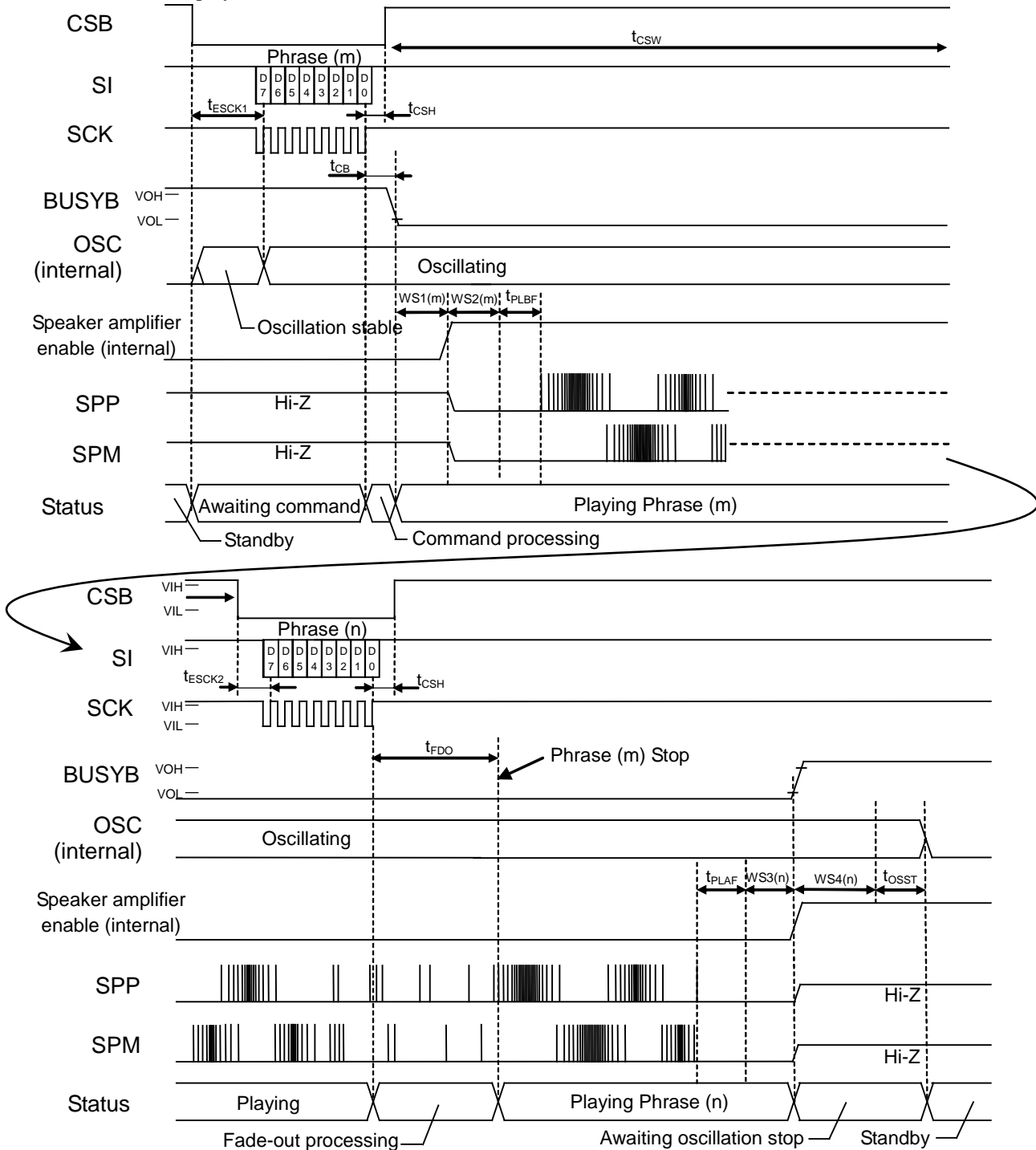

- The wait time of WS1, WS2, WS3, and WS4 can be set up for every phrase, when creating sound data using Speech Utility.
- About this function, refer to "3. PHRASEn command" in "Description of Command Functions"

● Timing which stops the playback in Scheduled Play mode

After inputting the STOP command, a phrase is played back to the last and the playback is stopped.

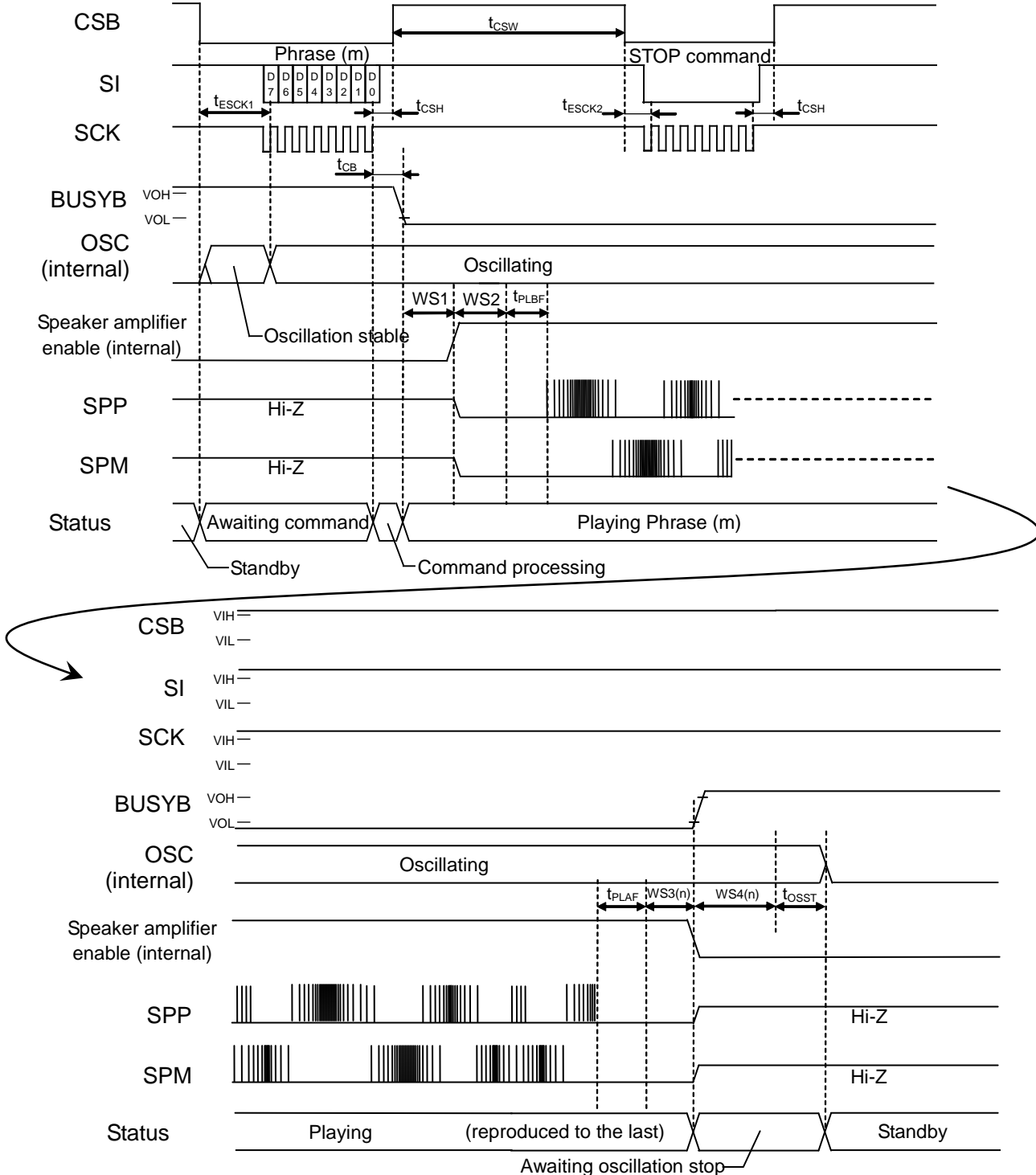

- The wait time of WS1, WS2, WS3, and WS4 can be set up for every phrase, when creating sound data using Speech Utility.
- Confirm the completion (BUSYB= "H") of the playback after input of a STOP command. Next, input the next command (PHRASEn command).
- About this function, refer to "3. PHRASEn command" in "Description of Command Functions"

● Timing which stops the playback in Change Immediately mode and Change Immediately Once mode  
 After inputting the STOP command, fade-out of the playback is carried out and the playback is stopped.

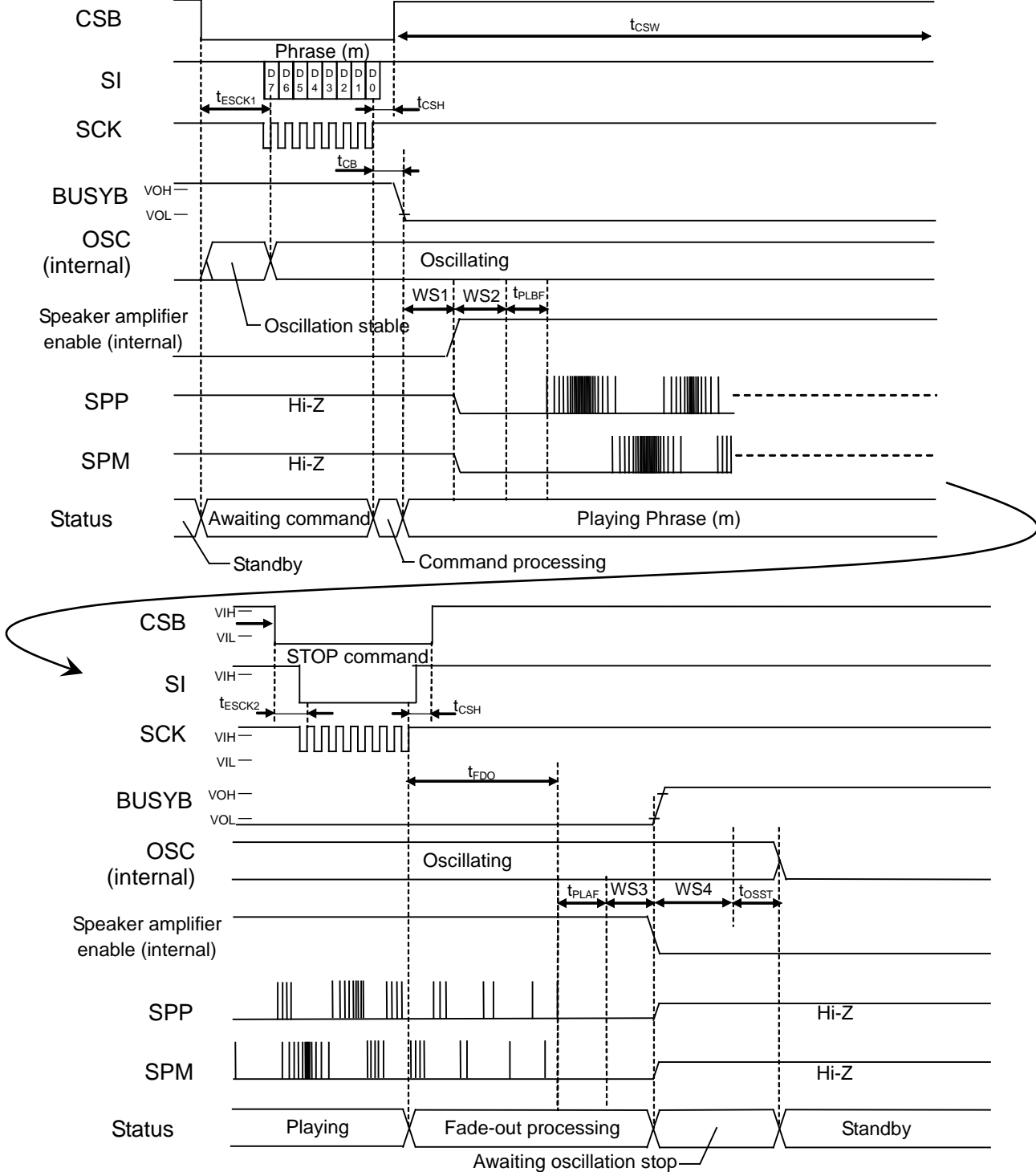

- The wait time of WS1, WS2, WS3, and WS4 can be set up for every phrase, when creating sound data using Speech Utility.
- Confirm the completion (BUSYB= "H") of the playback after input of a STOP command. Next, input the next command (PHRASEn command).
- About this function, refer to "3. PHRASEn command" in "Description of Command Functions"

● Disconnection detection Timing

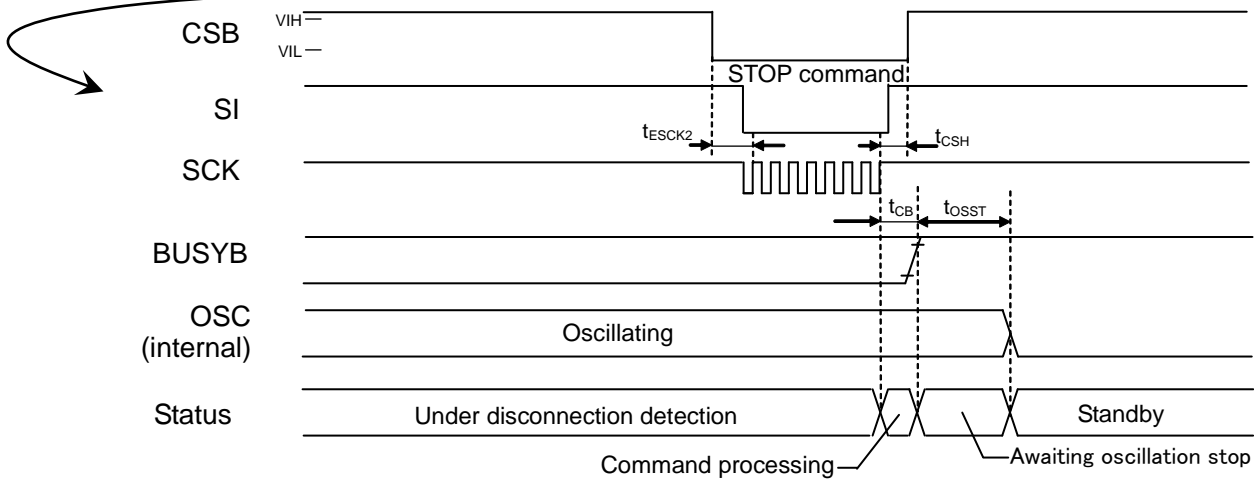
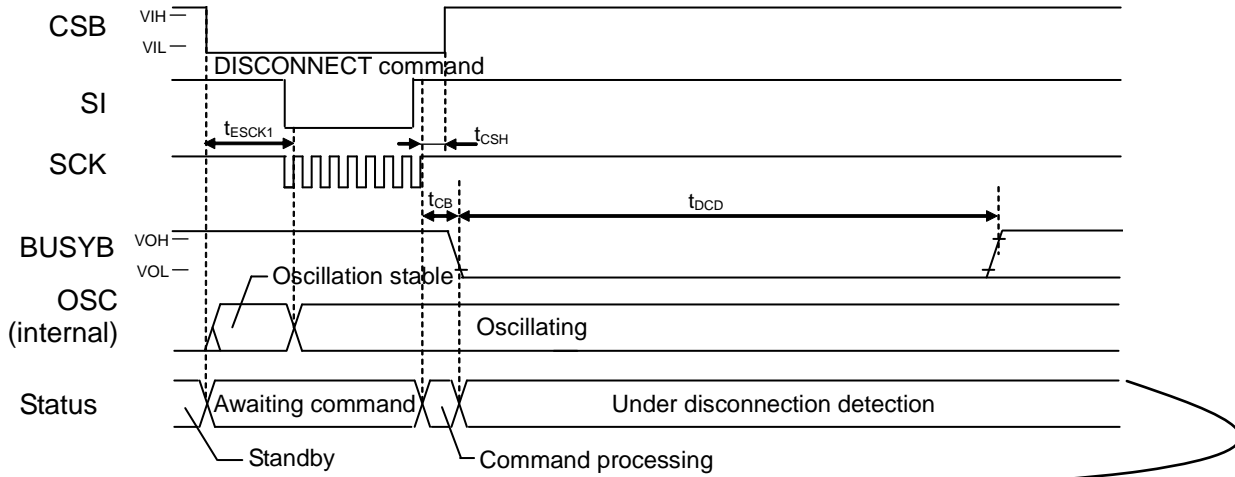

● Speaker pin short detection Timing

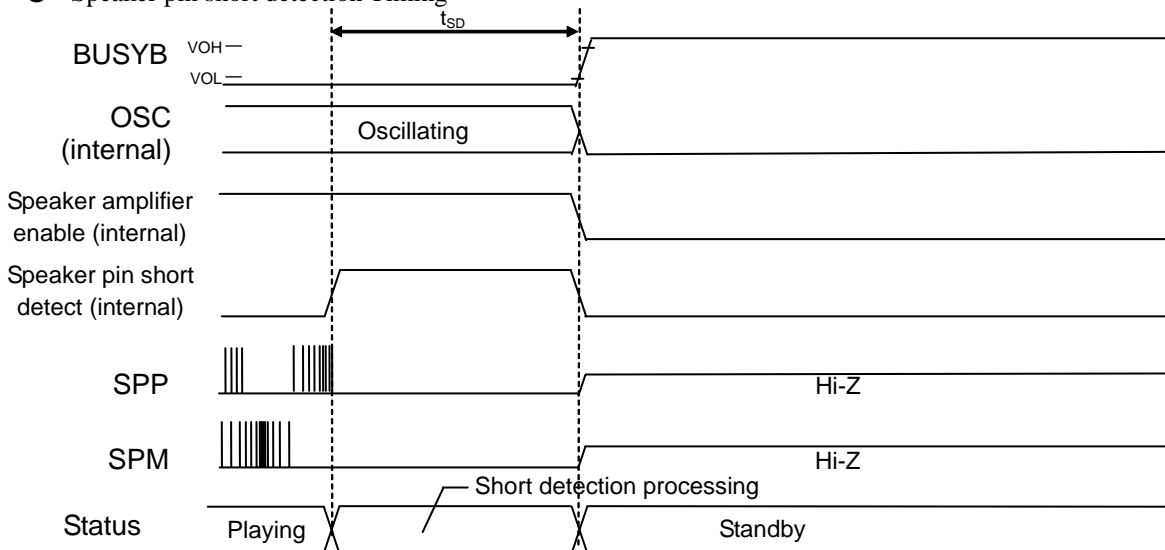



■ FUNCTIONAL DESCRIPTION

● Synchronous Serial Command Interface

The CSB, SCK, SI pins are used to input the command data. Driving the CSB pin to “L” level enables the serial CPU interface. After the CSB pin is driven to “L” level, the command data are input through the SI pin from the MSB or LSB synchronized with the SCK clock. The command data shifts in through the SI pin at the rising edge of the SCK clock pulse. Then, a command is executed at the rising edge of the eighth pulse of the SCK clock.

The initial value of the SCK pin can be chosen by the mask option of Speech Utility. When setting the initial value of the SCK pin as "H" level, please choose “Nomal ("H" Level)” as a mask option. When setting the initial value of the SCK pin as "L" level, please choose “Reversal("L" Level)” as a mask option.

After a command input should return the CSB pin to "H" level.

Data input timing

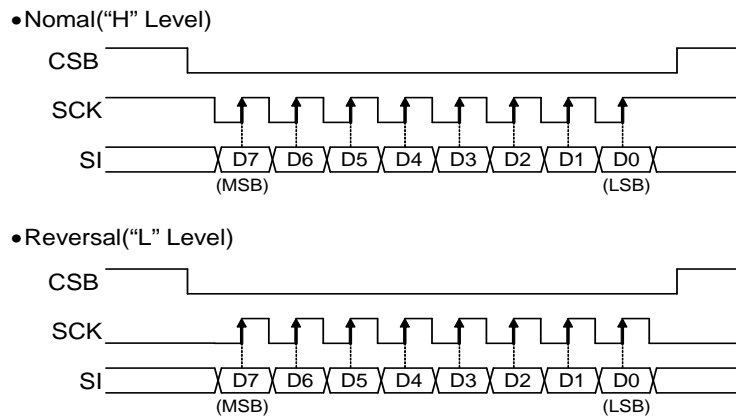

The synchronous serial interface option can be set up on the option screen of Speech Utility shown in figure .1.

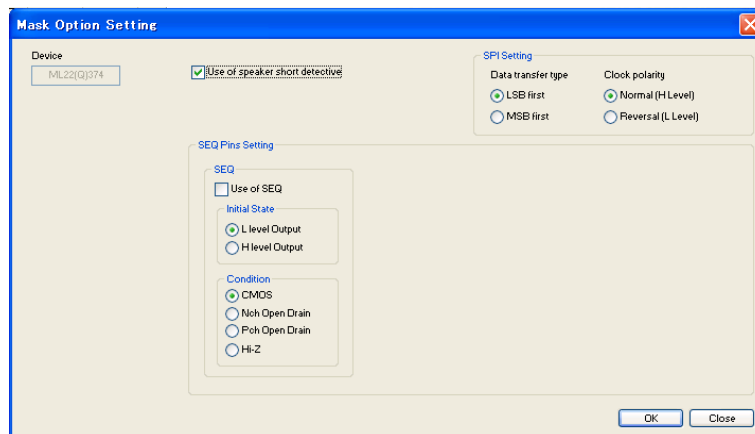

Figure .1 The option screen of Speech Utility

● Command List

Each command is configured by the unit of byte (8-bit).

Command	D7	D6	D5	D4	D3	D2	D1	D0	Description
STOP	0	0	0	0	0	0	0	0	Stop command. The STOP command becomes effective except the phrase in Play Once mode and Scheduled Play Once mode.
DISCONNECT	0	0	0	0	0	0	0	1	Disconnection detection command. Please input the STOP command, after you use the DISCONNECT command.
PHRASE2	V2	V1	V0	0	0	0	1	0	Phrase command
PHRASE3	V2	V1	V0	0	0	0	1	1	
PHRASE31	V2	V1	V0	1	1	1	1	1	

● Voice Synthesis Algorithm

Four types of voice synthesis algorithm are supported. They are 4-bit ADPCM2, 8-bit non-linear PCM, 8-bit straight PCM and 16-bit straight PCM. Select the best one according to the characteristics of voice.

The following table shows key features of each algorithm.

Voice synthesis algorithm	Applied waveform	Feature
4-bit ADPCM2	Normal voice waveform	Up version of LAPIS Semiconductor's specific voice synthesis algorithm (: 4-bit ADPCM). Voice quality is improved.
8-bit Nonlinear PCM	Waveform including high frequency signals (sound effect, etc.)	Algorithm, which plays back mid-range of waveform as 10-bit equivalent voice quality.
8-bit straight PCM		Normal 8-bit PCM algorithm
16-bit straight PCM		Normal 16-bit PCM algorithm

● Memory Allocation and Creating Voice Data

The ROM is partitioned into four data areas: voice (i.e., phrase) control area, test area, voice area, and edit ROM area.

The voice control area manages the voice data in the ROM. It contains data for controlling the start/stop addresses of voice data for 1,024 phrases, use/non-use of the edit ROM function and so on.

The test area contains data for testing.

The voice area contains actual waveform data.

The edit ROM area contains data for effective use of voice data. For the details, refer to the section of “Edit ROM Function.”

The edit ROM area is not available if the edit ROM is not used.

The ROM data is created using a dedicated tool.

Configuration of ROM data

0x00000	Prohibition of use area (Fixed 64 Kbits)
0x01FFF	
0x02000	Voice area 2
max.0x0FBFF	
0x0FFFF	Edit ROM area Depends on creation of ROM data.
max.0x0FBFF	
0x0FC00	Test area
0x0FFFF	
0x10000	Voice control area (Fixed 4 Kbits)
0x101FF	
0x10200	Voice area 1
0x17FFF	

● Playback Time and Memory Capacity

The playback time depends on the memory capacity, sampling frequency, and the playback method.

The equation to know the playback time is shown below. But this is not applied if the edit ROM function is used.

$$\text{Playback time [sec]} = \frac{1.024 \times (\text{Voice area 1} + \text{Voice area 2}) \text{ [Kbits]}}{\text{Sampling frequency [kHz]} \times \text{Bit length}}$$

(Bit length is 4 at the 4-bit ADPCM2 and 8/16 at the PCM.)

Example) In the case that the sampling frequency is 8 kHz, algorithm is 4-bit ADPCM2, the playback time is approx. 22.1 seconds, as shown below.

$$\text{Playback time} = \frac{1.024 \times 692 \text{ [Kbits]}}{8 \text{ [kHz]} \times 4 \text{ [bits]}} \cong 22.1 \text{ [sec]}$$

Make the playback time of one phrase more than 20msec.

● Edit ROM Function

The edit ROM function makes it possible to play back multiple phrases in succession. The following functions are set using the edit ROM function:

- Continuous playback:                    There is no limit to set the number of times of the continuous playback. It depends on the memory capacity only.
- Silence insertion function:            20ms to 1,024 ms  
Note: Silent insertion time varies for  $\pm 1$ ms by the sampling frequency

It is possible to use voice ROM effectively to use the edit ROM function. Below is an example of the ROM structure, case of using the edit ROM function.

Example 1) Phrases using the Edit ROM Function

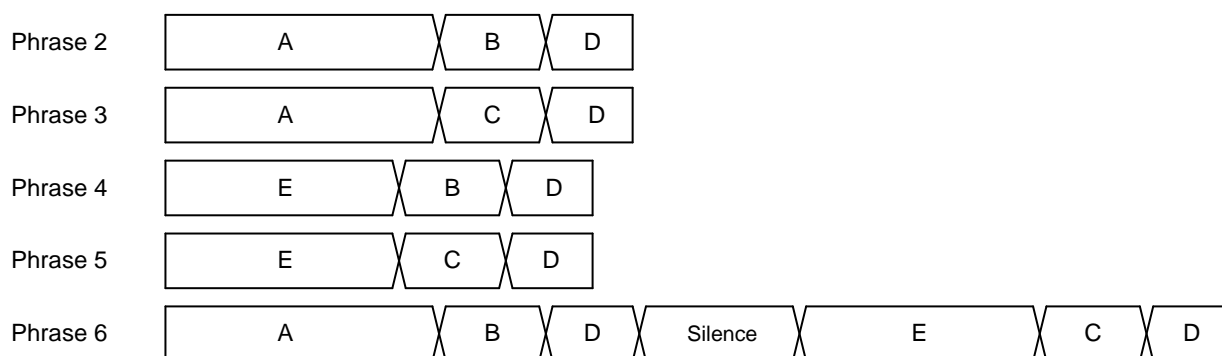

Example 2) Structure of the ROM that contents of Example 1 are stored

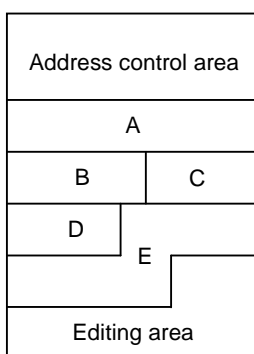

● Notice of silence insertion function

If it is only silence phrase registered, please put in order three or more silence phrase.  
The phrase which is constituted from one or two of silence phrase does not playback.

Example 3) Phrase composition in the case of using silence insertion function

The phrase to playback (The phrase 2 is played back twice on both sides of 1 sec silence.)

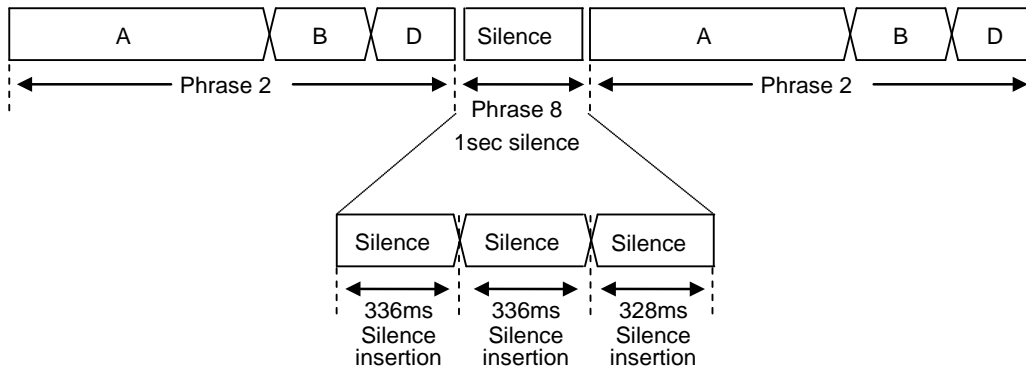

1 sec which is constituted by the three silences is registered as the phrase 8.

● Notice of the silence insertion function, which a "Mute Time" was used for.

When "Mute Time" is used at the end of phrase, the continuous playback of that phrase isn't done.

Modify it to the sound which "Mute Time" was used for and the silence voice data in the case of the continuous playback mode.

Example 4) Phrase composition in the case of continuous playback using silence insertion function

The case of continuous playback using Scheduled play mode.

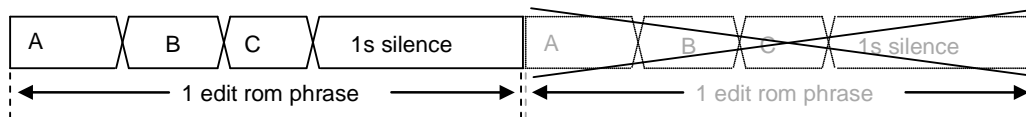

When "Mute Time"(1s silence) is used at the end of phrase, the continuous playback of that phrase isn't done.

Change "Mute Time"(1s silence) to the combination of "Mute Time"(980ms silence) and the silence voice data\*1 of 20ms".

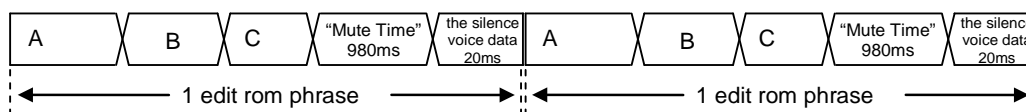

\*1 : The data that sound-less was made by the voice data are the silence voice data.

In the case of 20ms, it can be realized with 128Byte by choosing sampling frequency 6.4kHz, the 8bit PCM mode.

● Speaker Pin Short Detection Function

The speaker pin short detection function detect the short-circuit between SPP pin and SPM pin, or between SPP/SPM pin and GND during playback. When short-circuit of a speaker pin is detected, the playback will be stopped automatically, BUSYB pin will become "H" level, and LSI will become in a standby state.

In addition, this function can be set up with the option screen of Speech Utility.

Please refer to a "Mask Option Setting setting item" for the option screen of Speech Utility.

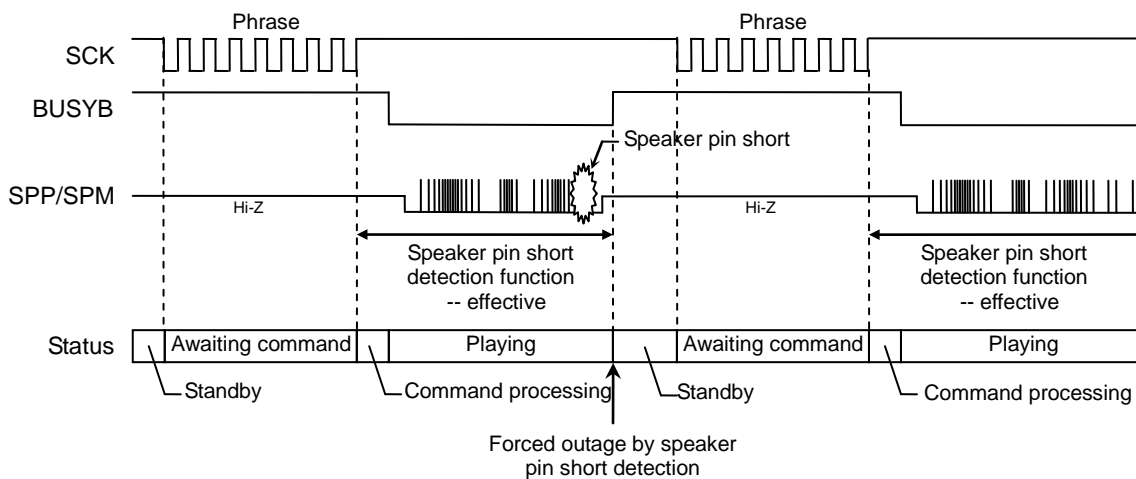

● Description of Command Functions

1. STOP command

• command 

0	0	0	0	0	0	0	0
---	---	---	---	---	---	---	---

The STOP command is used to stop the playback. BUSYB pin will become "H", if the playback is stopped. The STOP command becomes effective except the phrase in Play Once mode and Scheduled Play Once mode. When you use Play Once mode or Scheduled Play Once mode, the STOP command is ignored.

When you use Scheduled Play mode, a phrase is played back to the last and the playback is stopped, after the STOP command is inputted. Furthermore, when you use Change Immediately Once mode or Change Immediately mode, fade-out of the playback is carried out and the playback is stopped, after the STOP command is inputted.

Confirm the completion (BUSYB= "H") of the playback after input of a STOP command. Next, input the next command (PHRASEn command).

• STOP command operation in the case of Scheduled Play mode

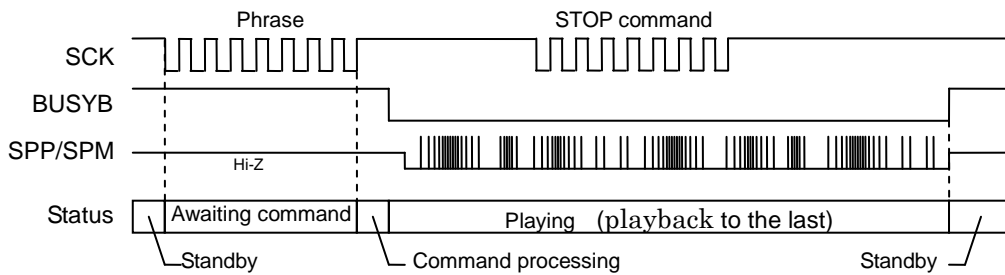

• STOP command operation in the case of Change Immediately Once mode or Change Immediately mode

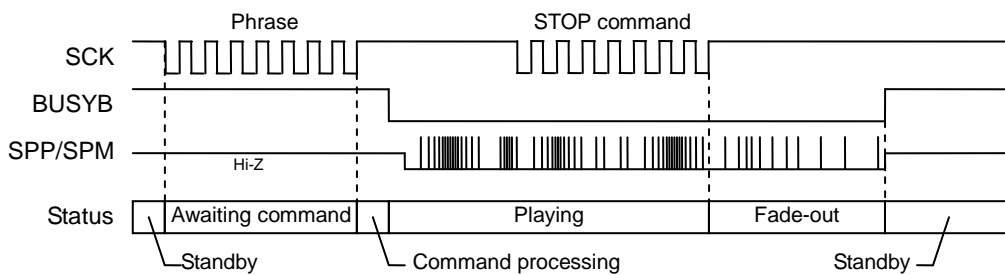

2. DISCONNECT command

• command 

0	0	0	0	0	0	0	0	1
---	---	---	---	---	---	---	---	---

The DISCONNECT command is used to diagnose whether the speaker is disconnected or not. When the speaker is disconnected, BUSYB pin outputs "L". Please input the STOP command, after you use the DISCONNECT command.

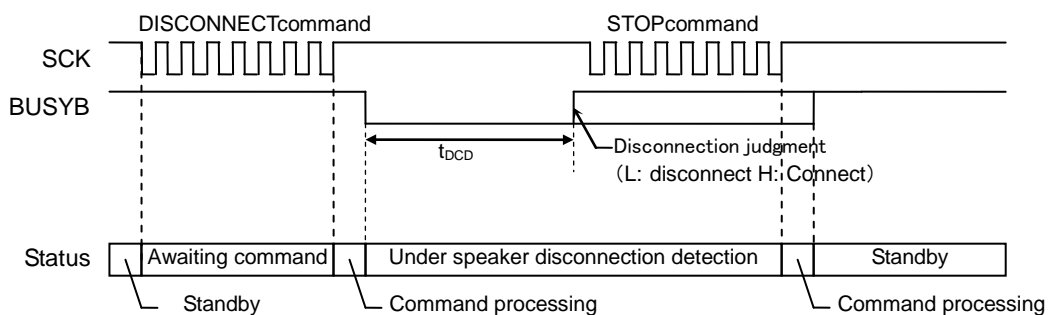



3. PHRASEn (n = 2 to 31) command

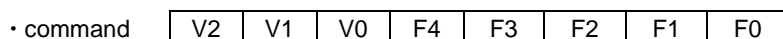

The PHRASEn (n = 2 to 31) command is used to start playback phrase. When you create the voice data, please set up the phrase address using Speech Utility.

The timing in the case of the playback a phrase address below is shown.

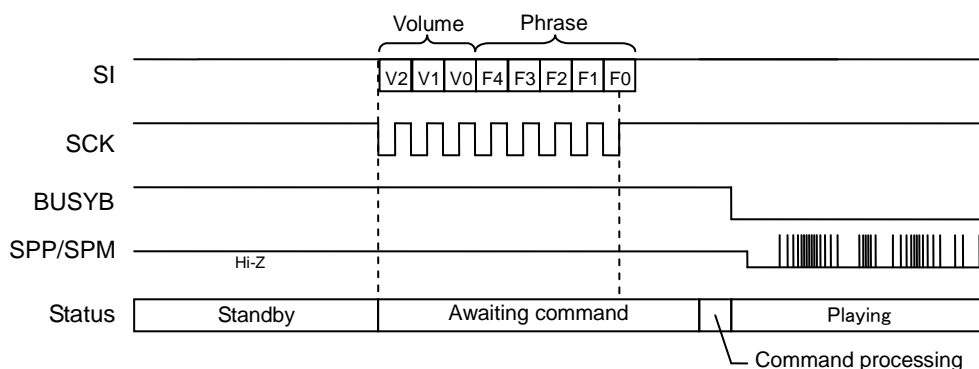

The PHRASEn(n=2 to 31) command can perform a volume setup. When V2-V0 is "000", the volume setup of voice control area is used.

V2	V1	V0	Volume [dB]
0	0	0	The volume setup of voice control area is used.*1
0	0	1	+2.98
0	1	0	+1.78
0	1	1	0
1	0	0	-2.25
1	0	1	-5.28
1	1	0	-9.99
1	1	1	-21.04

\*Note 1: For edited phrase, volume set for each registered phrase is used

Each phrase can set up the wait time before and after playback, a volume setup, and playback mode using Speech Utility.



Figure .2 The option screen for every phrase of Speech Utility

1) Wait time setting before and after playback (WS1, WS2, WS3, WS4)

Each phrase can set up the wait time before and after playback. Since it is an option setup, change will be impossible once it sets up.

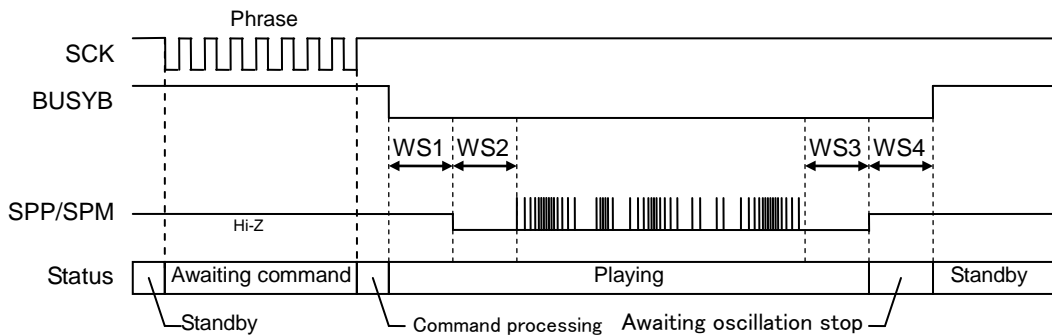

WS1: Time after inputting a phrase address, until SPP/SPM pins are enabled.

WS2: Time after SPP/SPM pins are enabled, until playback is started.

WS3: Time after playback is completed, until SPP/SPM pins are disabled.

WS4: Time after SPP/SPM pins are disabled, until it will be in a standby state.

WS1-WS4 can be arbitrarily set up between 0 to 1020ms (4ms unit).

2) Volume setup (Volume)

Each phrase can set up the volume setup. Since it is an option setup, change will be impossible once it sets up.

Value [hex]	Volume [dB]	Value [hex]	Volume [dB]	Value [hex]	Volume [dB]
00h	+2.98	0Ah	-0.41	15h	-6.87
01h	+2.70	0Bh	-0.83	16h	-7.79
02h	+2.40	0Ch	-1.28	17h	-8.82
03h	+2.10	0Dh	-1.75	18h	-9.99
04h	+1.78	0Eh	-2.25	19h	-11.34
05h	+1.45	0Fh	-2.77	1Ah	-12.94
06h	+1.11	10h	-3.34	1Bh	-14.90
07h	+0.76	11h	-3.94	1Ch	-17.44
08h	+0.39	12h	-4.58	1Dh	-21.04
09h	+0.00	13h	-5.28	1Eh	-27.31
		14h	-6.04	1Fh	OFF

3) Playback mode setup

Playback mode can be set up for every phrase. Since it is an option setup, change will be impossible once it sets up.

Playback mode	Operation
Play Once	This mode is playback once. All the commands become invalid during playback.
Scheduled Play Once	When the following phrase is inputted into playback, after playback of the present phrase is completed, playback of the following phrase starts. Even if STOP command is inputted during playback, it will be ignored.
Change Immediately Once	When the following phrase is inputted into playback, playback of the present phrase is ended on the way, and playback of the following phrase starts.
Scheduled Play	The playback continues until the following command will be inputted, if playback starts. When the following command is inputted into playback, after playback of the present phrase is completed, the following command is executed.
Change Immediately	The playback continues until the following command will be inputted, if playback starts. When the following phrase is inputted into playback, playback of the present phrase is ended on the way, and playback of the following phrase starts.

• Play Once mode

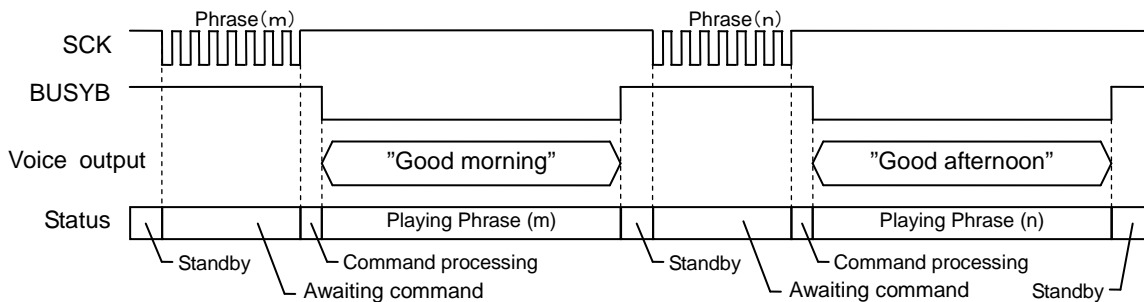

• Scheduled Play Once mode

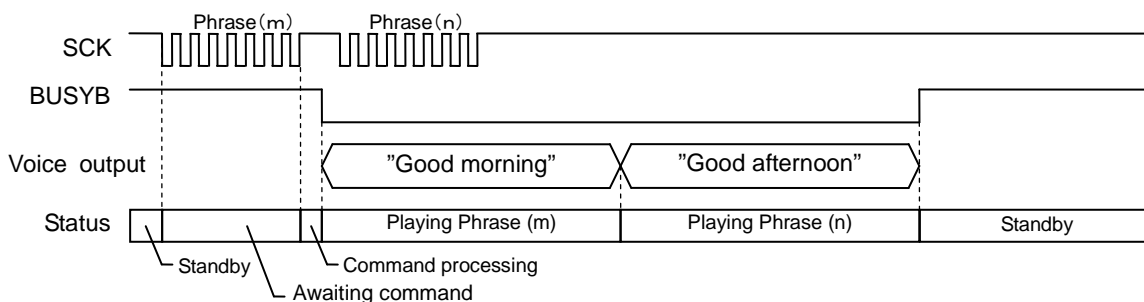

Start the next PHRASEn command within the tNCM. When it can't start, confirm the completion (BUSYB= "H") of the playback. Next, input the next command (PHRASEn command).

• Change Immediately Once mode

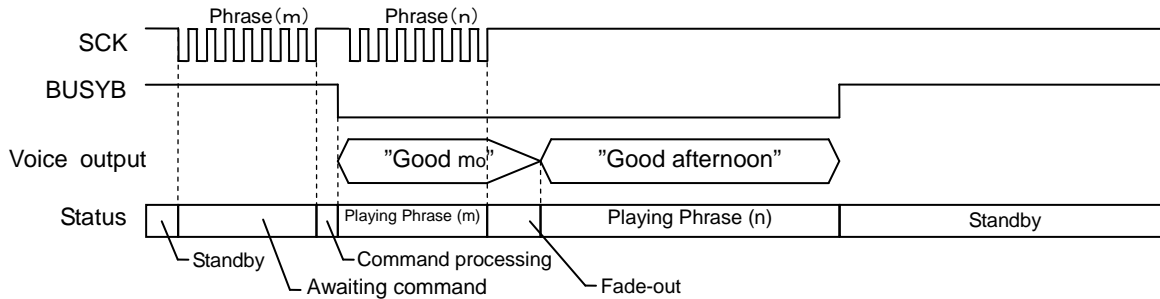

• Scheduled Play mode

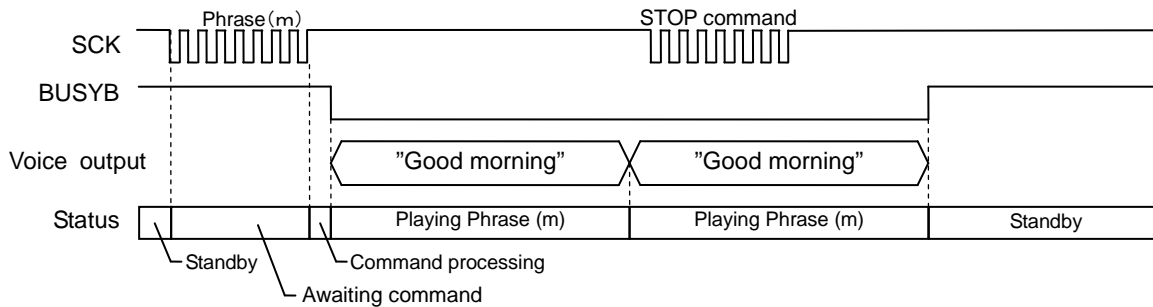

Confirm the completion (BUSYB= "H") of the playback after input of a STOP command. Next, input the next command (PHRASEn command).

• Change Immediately mode

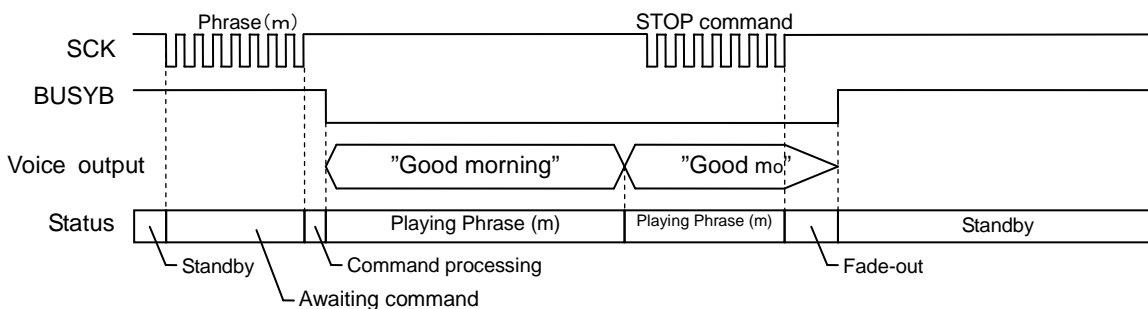

Confirm the completion (BUSYB= "H") of the playback after input of a STOP command. Next, input the next command (PHRASEn command).

● Mask Option Setting

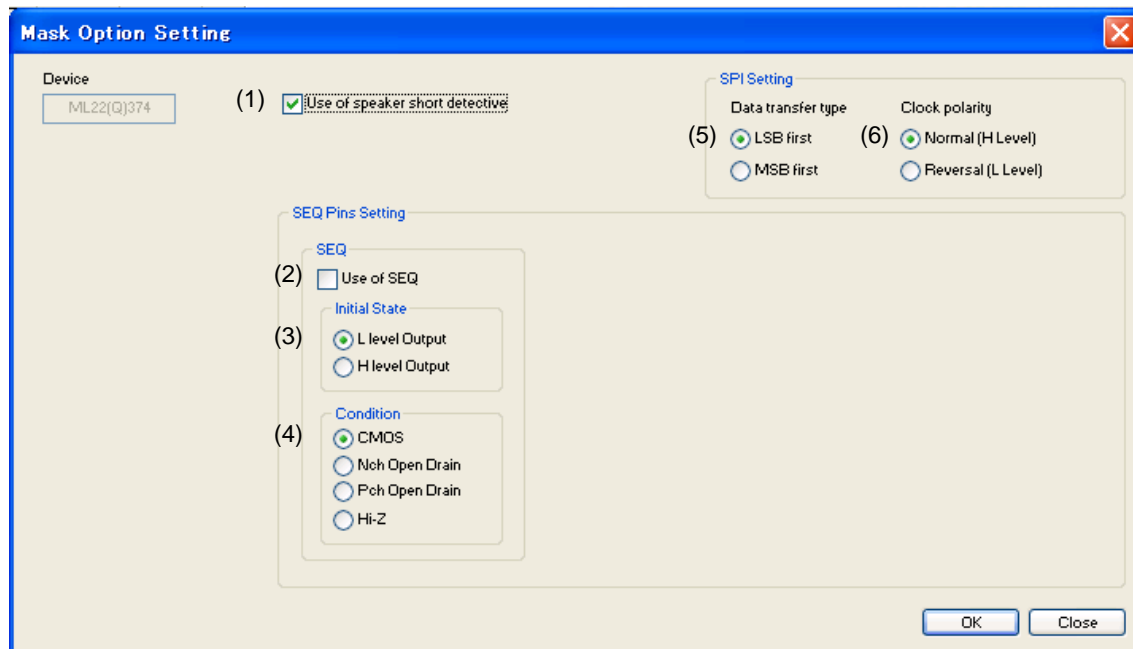

Figure .3 The Mask Option Setting screen of Speech Utility

Explanation of each option is shown in the following page.

Parameter	Function	Explanation
(1) Use of speaker short detective	ON or OFF selection of a short detection function	If a check box is turned on, a short detection circuit will become effective.
SEQ Pins Setting	Interface setup	
SEQ	BUSYB setup	
(2) Use SEQ	Use or unuse selection of BUSYB	If a check box is turned on, a BUSYB pin can be used. If a check box is turned off, a BUSYB pin does not function but the fixed output of the initial value is carried out.
(3) Initial State	Initial output level selection of BUSYB	The initial value of a BUSYB pin at voice stop can be chosen.
L Level Output	L Level Output	The "L" level is outputted at voice stop. "H" level is outputted at speech playback.
H Level Output	H Level Output	The "H" level is outputted at voice stop. "L" level is outputted at speech playback.
(4) Condition	BUSYB condition setup	BUSYB condition can be chosen.
CMOS	CMOS output	A BUSYB pin become a CMOS output. <u>Usually, please use this setup.</u>
Nch Open Drain	Nch Open Drain output	The "L" level is outputted at the "L" level. High impedance is outputted at the H" level.
Pch Open Drain	Pch Open Drain output	The "H" level is outputted at the "H" level. High impedance is outputted at the L" level.
Hi-Z	High impedance output	High impedance is always outputted. When BUSYB use mode is set up, please do not use it.
SPI Setting	Synchronous Serial Interface	
(5) Data transfer type	Data input format	Data input format can be chosen from LSB first or MSB first.
LSB first	LSB first	Serial data is inputted at LSB first.
MSB first	MSB first	Serial data is inputted at MSB first.
(6) Clock polarity	Serial Clock setup	The initial value of the SCK pin can be chosen.
Nomal("H" Level)	An initial value is "H" level.	An initial value of the SCK pin is "H" level.
Reversal("L" Level)	An initial value is "L" level.	An initial value of the SCK pin is "L" level.

■ Termination of the  $V_{DDL}$  Pin

The  $V_{DDL}$  pin is the regulator output that is power supply pin for the internal logic circuits. Connect a capacitor between this pin and the ground in order to prevent noise generation and power fluctuation. The recommended capacitance value is shown below. However, it is important to evaluate and decide using the own board. Also, start the next operation after each output voltage is stabilized.

Pin	Recommended capacitance value	Remarks
$V_{DDL}$	10 $\mu$ F $\pm$ 20%	The larger the connection capacitance, the longer the settling time.

■ POWER SUPPLY WIRING

The power supplies of this LSI are divided into the following two:

- Power supply for logic circuitry (:  $DV_{DD}$ )
- Power supply for speaker amplifier (:  $SPV_{DD}$ )

The example of power connection is shown below.

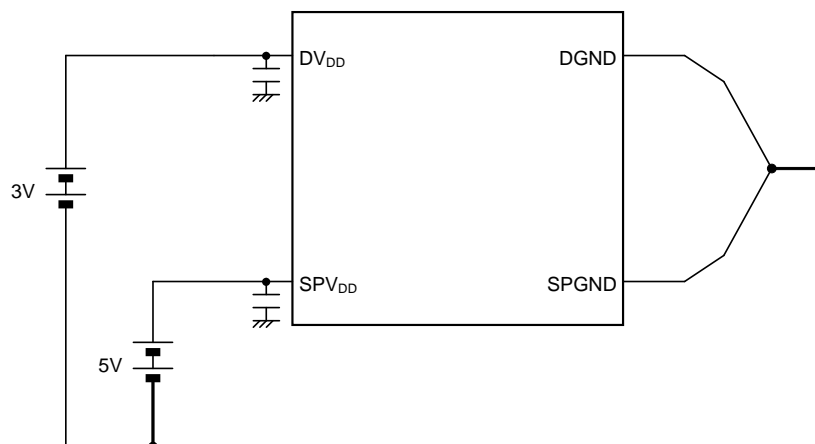
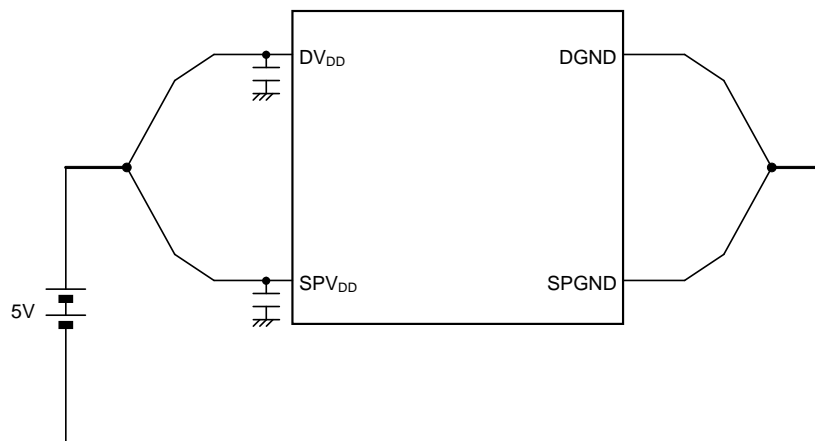

- Turn on  $DV_{DD}$  and  $SPV_{DD}$  simultaneously, or turn on  $SPV_{DD}$  after turning on  $DV_{DD}$ .
- Turn off  $DV_{DD}$  and  $SPV_{DD}$  simultaneously, or turn off  $DV_{DD}$  after turning on  $SPV_{DD}$ .

■ APPLICATION CIRCUIT

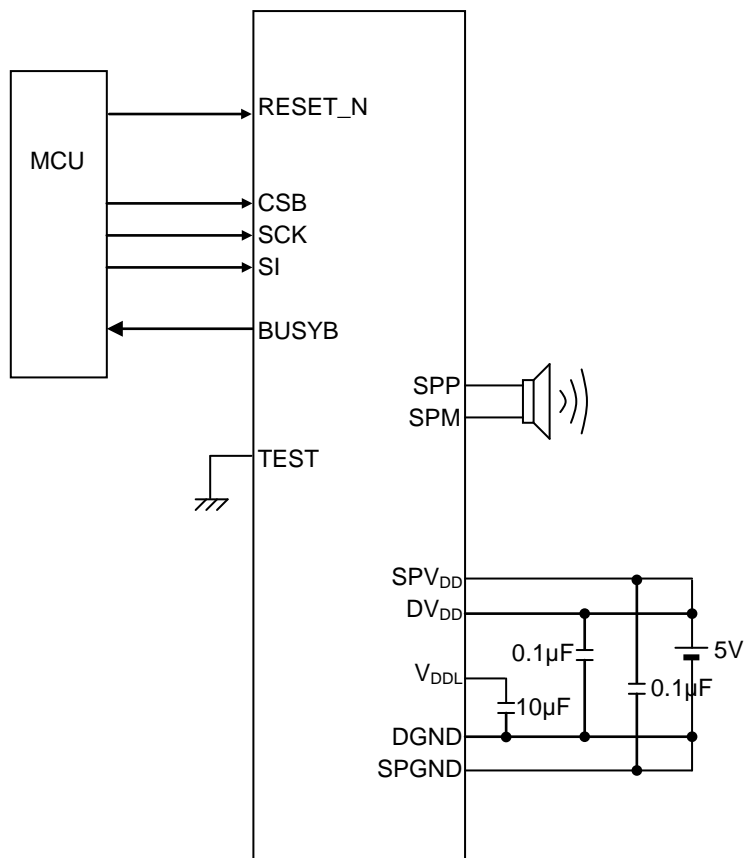



■ PACKAGE DIMENSIONS (16-pin plastic SSOP)

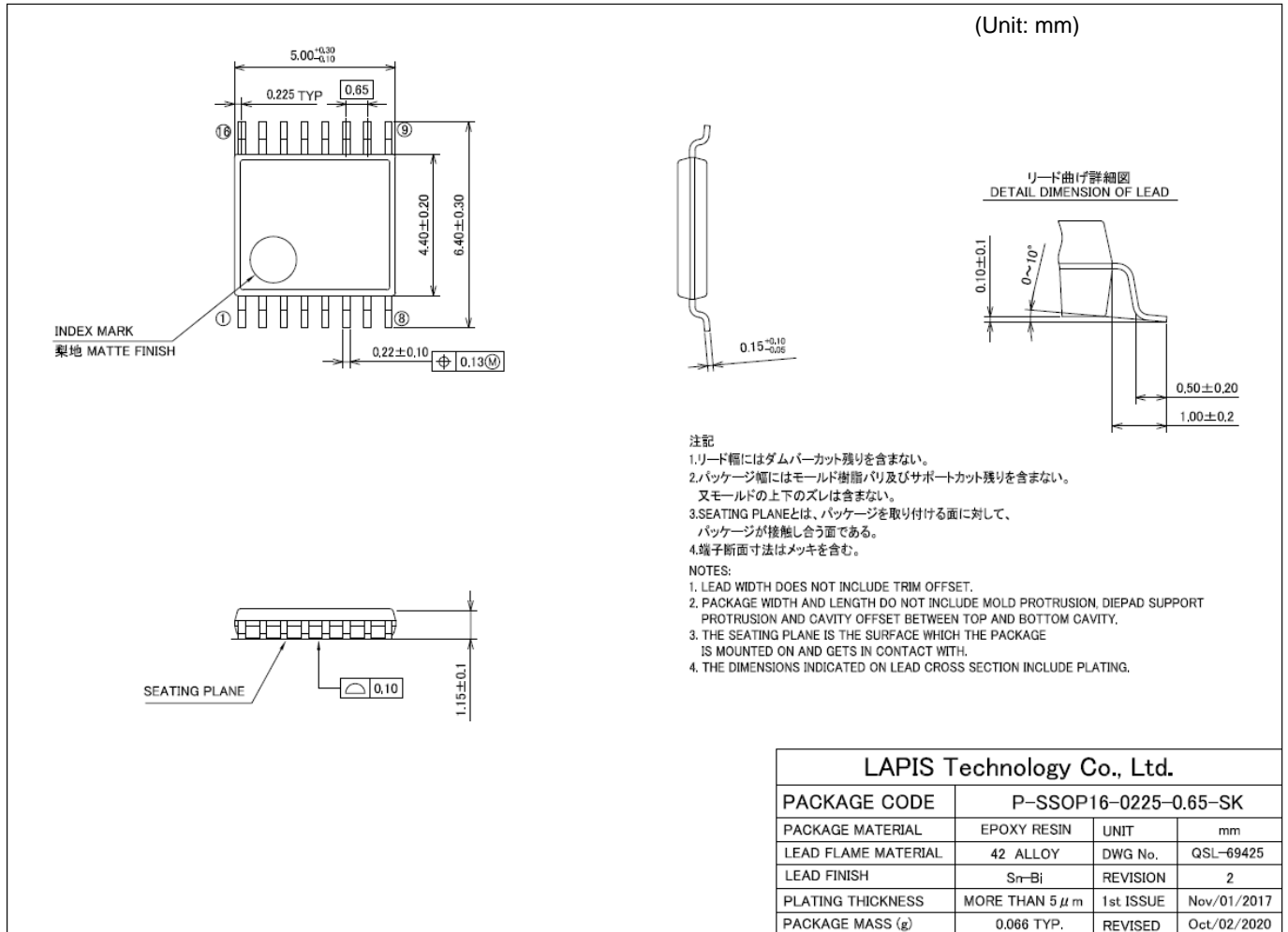

Notes for Mounting the Surface Mount Type Package

The surface mount type packages are very susceptible to heat in reflow mounting and humidity absorbed in storage. Therefore, before you perform reflow mounting, contact a ROHM sales office for the product name, package name, pin number, package code and desired mounting conditions (reflow method, temperature and times).

■ PACKAGE DIMENSIONS (20-pin plastic TSSOP)

(Unit: mm)

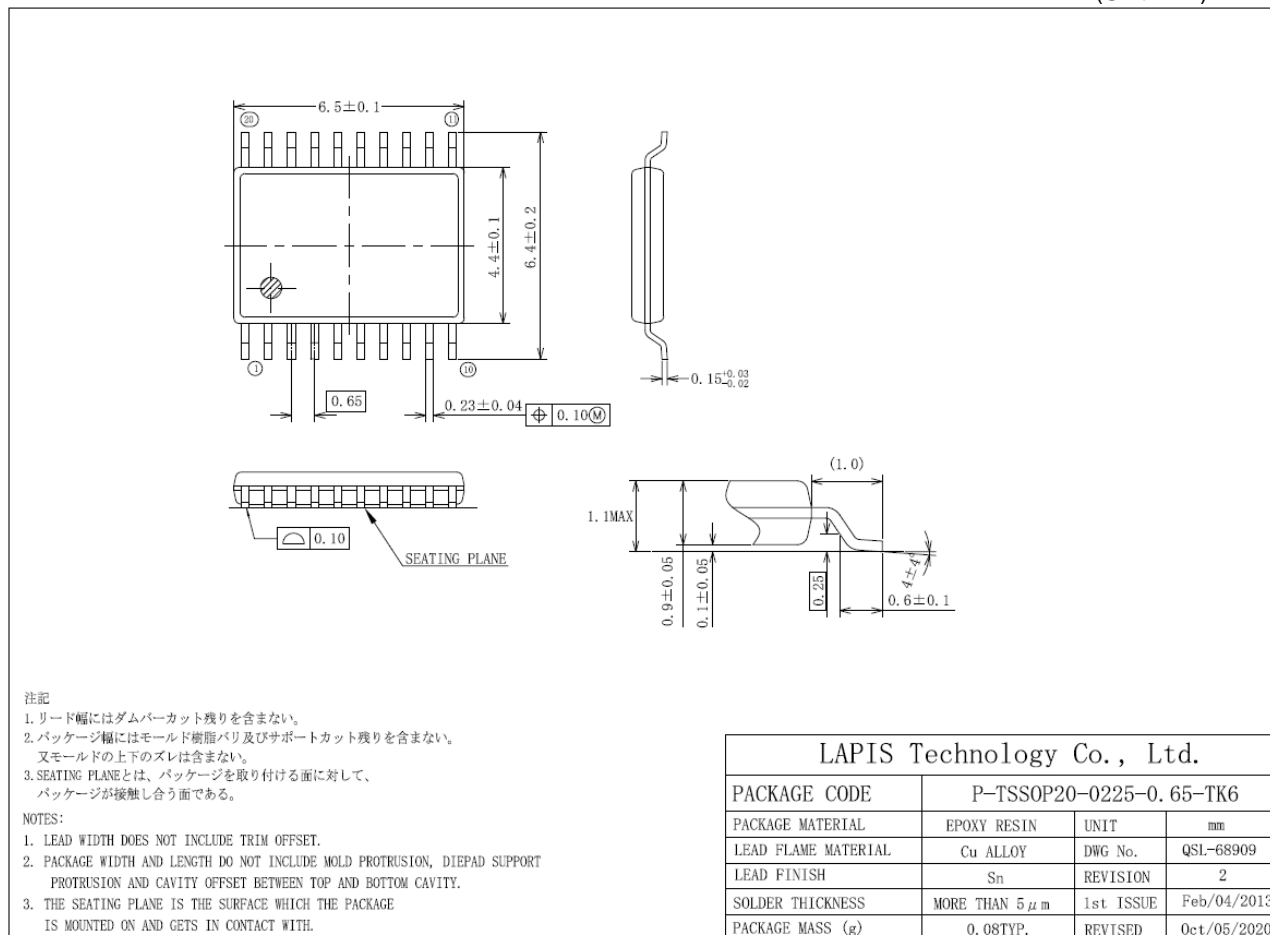

Notes for Mounting the Surface Mount Type Package

The surface mount type packages are very susceptible to heat in reflow mounting and humidity absorbed in storage. Therefore, before you perform reflow mounting, contact a ROHM sales office for the product name, package name, pin number, package code and desired mounting conditions (reflow method, temperature and times).

## ■ Revision History

Document No.	Date	Page		Description
		Previous Edition	Current Edition	
FEDL22Q374FULL-01	Oct. 23, 2012	–	–	Final edition 1
FEDL22Q374-02	Jun. 06, 2014	21	21	Add the Notice of silence insertion function
FEDL22Q374-03	Mar. 16, 2015	8	8	Modify the explanation of tNCM.
		12	12	Add the t <sub>CSW</sub> . Add the notice of the next PHRASEn command input.
		13	13	Add the t <sub>CSW</sub> .
		14	14	Add the t <sub>CSW</sub> . Add the notice of the next PHRASEn command input.
		15	15	Add the t <sub>CSW</sub> . Add the notice of the next PHRASEn command input.
		19	19	Add the notice of minimum playback time.
		21	21	Add the notice of the silence insertion function.
		23	23	Add the notice of the next PHRASEn command input.
FEDL22Q374-04	Apr. 01, 2016	27-28	27-28	Add the notice of the next PHRASEn command input.
FEDL22Q374-04	Apr. 01, 2016	2	2	Deleted ML22330/ML22Q330 and ML22Q384.
FEDL22Q374-05	Oct. 31, 2017	2	2	Modify the Sampling frequency.
		5	5	Modify the BUSYB.
		30	30	Modify the Initial output level selection of BUSYB.
FEDL22Q374-06	Jul. 31, 2019	1	1	Add 20pin TSSOP and ML22Q374-NNN/ML22Q374-xxxTD Add Plan to qualify AEC-Q100
		2	2	Add 20pin TSSOP
		3	3	Add ML22Q374-NNNTD/ML22Q374-xxxTD
		4	4	Add 20pin TSSOP
		5	5	Add 20pin assign
		33	33	Add 16pin SSOP
FEDL22Q374-07	May. 17, 2021	34	34	Add package dimensions to 20 PIN TSSOP
		1	1	Add ML22Q374P to Product name Add ML22Q374P to Operating temperature range Modify AEC-Q100 Plan to AEC-Q100 Compliant Add ML22Q374P-NNNTD/ML22Q374P-xxxTD to Product name
		2	2	Add ML22Q374P, ML22Q394P to a table
		3	3	Add ML22Q374P-NNNTD/ML22Q374P-xxxTD
		4	4	Add ML22Q374P-NNNTD/ML22Q374P-xxxTD to 20-Pin Plastic TSSOP
		6	6	Add ML22Q374P to Operating temperature of RECOMMENDED OPERATING CONDITIONS
		7	7	Add ML22Q374P to Operating Condition Add Ta ≤ +105°C to Standby supply current, Ta = -40 to +105°C to Source oscillation frequency Add ML22Q374P to Speaker amplifier output power
		8	8	Add ML22Q374P to Operating Condition
		25	25	Add the note of the volume
33	33	Modify P-SSOP16-0225-0.65-UK to P-SSOP16-0225-0.65-SK		

**■ Notes**

- 1) The information contained herein is subject to change without notice.
- 2) When using LAPIS Technology Products, refer to the latest product information (data sheets, user's manuals, application notes, etc.), and ensure that usage conditions (absolute maximum ratings, recommended operating conditions, etc.) are within the ranges specified. LAPIS Technology disclaims any and all liability for any malfunctions, failure or accident arising out of or in connection with the use of LAPIS Technology Products outside of such usage conditions specified ranges, or without observing precautions. Even if it is used within such usage conditions specified ranges, semiconductors can break down and malfunction due to various factors. Therefore, in order to prevent personal injury, fire or the other damage from break down or malfunction of LAPIS Technology Products, please take safety at your own risk measures such as complying with the derating characteristics, implementing redundant and fire prevention designs, and utilizing backups and fail-safe procedures. You are responsible for evaluating the safety of the final products or systems manufactured by you.
- 3) Descriptions of circuits, software and other related information in this document are provided only to illustrate the standard operation of semiconductor products and application examples. You are fully responsible for the incorporation or any other use of the circuits, software, and information in the design of your product or system. And the peripheral conditions must be taken into account when designing circuits for mass production. LAPIS Technology disclaims any and all liability for any losses and damages incurred by you or third parties arising from the use of these circuits, software, and other related information.
- 4) No license, expressly or implied, is granted hereby under any intellectual property rights or other rights of LAPIS Technology or any third party with respect to LAPIS Technology Products or the information contained in this document (including but not limited to, the Product data, drawings, charts, programs, algorithms, and application examples, etc.). Therefore LAPIS Technology shall have no responsibility whatsoever for any dispute, concerning such rights owned by third parties, arising out of the use of such technical information.
- 5) The Products are intended for use in general electronic equipment (AV/OA devices, communication, consumer systems, gaming/entertainment sets, etc.) as well as the applications indicated in this document. For use of our Products in applications requiring a high degree of reliability (as exemplified below), please be sure to contact a LAPIS Technology representative and must obtain written agreement: transportation equipment (cars, ships, trains, etc.), primary communication equipment, traffic lights, fire/crime prevention, safety equipment, medical systems, servers, solar cells, and power transmission systems, etc. LAPIS Technology disclaims any and all liability for any losses and damages incurred by you or third parties arising by using the Product for purposes not intended by us. Do not use our Products in applications requiring extremely high reliability, such as aerospace equipment, nuclear power control systems, and submarine repeaters, etc.
- 6) The Products specified in this document are not designed to be radiation tolerant.
- 7) LAPIS Technology has used reasonable care to ensure the accuracy of the information contained in this document. However, LAPIS Technology does not warrant that such information is error-free and LAPIS Technology shall have no responsibility for any damages arising from any inaccuracy or misprint of such information.
- 8) Please use the Products in accordance with any applicable environmental laws and regulations, such as the RoHS Directive. LAPIS Technology shall have no responsibility for any damages or losses resulting non-compliance with any applicable laws or regulations.
- 9) When providing our Products and technologies contained in this document to other countries, you must abide by the procedures and provisions stipulated in all applicable export laws and regulations, including without limitation the US Export Administration Regulations and the Foreign Exchange and Foreign Trade Act..
- 10) Please contact a ROHM sales office if you have any questions regarding the information contained in this document or LAPIS Technology's Products.
- 11) This document, in part or in whole, may not be reprinted or reproduced without prior consent of LAPIS Technology.

(Note) "LAPIS Technology" as used in this document means LAPIS Technology Co., Ltd.

Copyright 2020 – 2021 LAPIS Technology Co., Ltd.

---

**LAPIS Technology Co.,Ltd.**

2-4-8 Shinyokohama, Kouhoku-ku, Yokohama 222-8575, Japan  
<https://www.lapis-tech.com/en/>