



ML22Q234

ADPCM Speech Synthesis LSI

■ GENERAL DESCRIPTION

ML22Q234 is a speech synthesis LSI that incorporates Flash for storing sound code data, and can be controlled with a Clock synchronization Serial interface.

By integrating D-class speaker amplifier, solution required for sound output is made possible with single chip.

● Playback time

Product name	Flash capacity (bit)	Maximum playback time (sec) (at $f_s^{*1} = 6.4 \text{ kHz}$)	
		HQ-ADPCM	16-bit Straight PCM
ML22Q234	676K (when 30 phrases are selected)	33.8	6.88
	672K (when 62 phrases are selected)	33.6	6.72

Note: Flash capacity shows the numerical value of only a sound area

*1: Sampling frequency

- Speech synthesis algorithm: HQ-ADPCM
4-bit ADPCM2
8-bit Nonlinear PCM
8-bit / 16-bit Straight PCM
(Can be specified for each phrase)
- Flash capacity: 676 Kbit (30 phrases selection), 672 Kbit (62 phrases selection)
- Sampling frequency (Fs): 6.4kHz, 8.0kHz, 10.7kHz, 12.8kHz, 16.0kHz,
21.3kHz, 25.6kHz, 32.0kHz
(Can be specified for each phrase)
- Speaker driving amplifier: D-class amplifier (driven by 8 Ω)
- CPU command interface: Clock synchronization Serial interface
- Maximum number of phrases: 30 phrases or 62 phrases
- Disconnection detection function
- Speaker pin short detection function
- Source oscillation frequency: 8.192MHz (Typ) (internal)
- Power supply voltage: 2.0 to 5.5 V
- Flash memory access function by MCU
- Flash memory rewritable time: 100 times
- Operating temperature range: -40°C ~ +85°C
- Package: 20-pin plastic TSSOP
ML22Q234-NNNTD/ML22Q234-xxxTD
(xxx: ROM code No.)



HQ-ADPCM is a high sound quality audio compression technology of "Ky's".
"Ky's" is a Registered trademark of National Universities corporate Kyushu
Institute of Technology



The following table shows the differences from ML22Q244, ML22Q254.

Parameter	ML22Q234 (This product)	ML22Q254	ML22Q244
MCU interface	Clock synchronization Serial	I ² C	Standalone
Flash capacity	676 Kbit (when 30 phrases are selected) 672 Kbit (when 62 phrases are selected)	←	692 Kbit (when 30 phrases are selected) 688 Kbit (when 62 phrases are selected)
Speech synthesis algorithm	HQ-ADPCM 4-bit ADPCM2 8-bit Nonlinear PCM 8-bit Straight PCM 16-bit Straight PCM	←	←
Maximum number of phrases:	30/62	←	←
Sampling frequency (kHz)	6.4/8.0/10.7/12.8/ 16.0/21.3/25.6/32.0	←	←
Clock frequency	8.192 MHz (internal oscillation)	←	←
Low-pass filter	FIR interpolation filter	←	←
Speaker driving amplifier	D-class amplifier	←	←
Speaker driving amplifier output load	8Ω	←	←
Speaker driving amplifier output voltage	1 W	←	←
Edit ROM function	Yes	←	←
Volume control	Code setting : 32 levels (Including Mute) Command setting : 31 levels	←	Code setting : 32 levels (Including Mute)
Silence insertion	4 ms to 1024 ms (4 ms/step)	←	←
Repeat function	Yes	←	←
Flash memory access function by MCU	Yes	←	No
Power supply voltage	2.0 to 5.5 V	←	←
Operating temperature range	-40 to +85°C	←	←
Package	20-pin plastic TSSOP	←	←

■ BLOCK DIAGRAMS

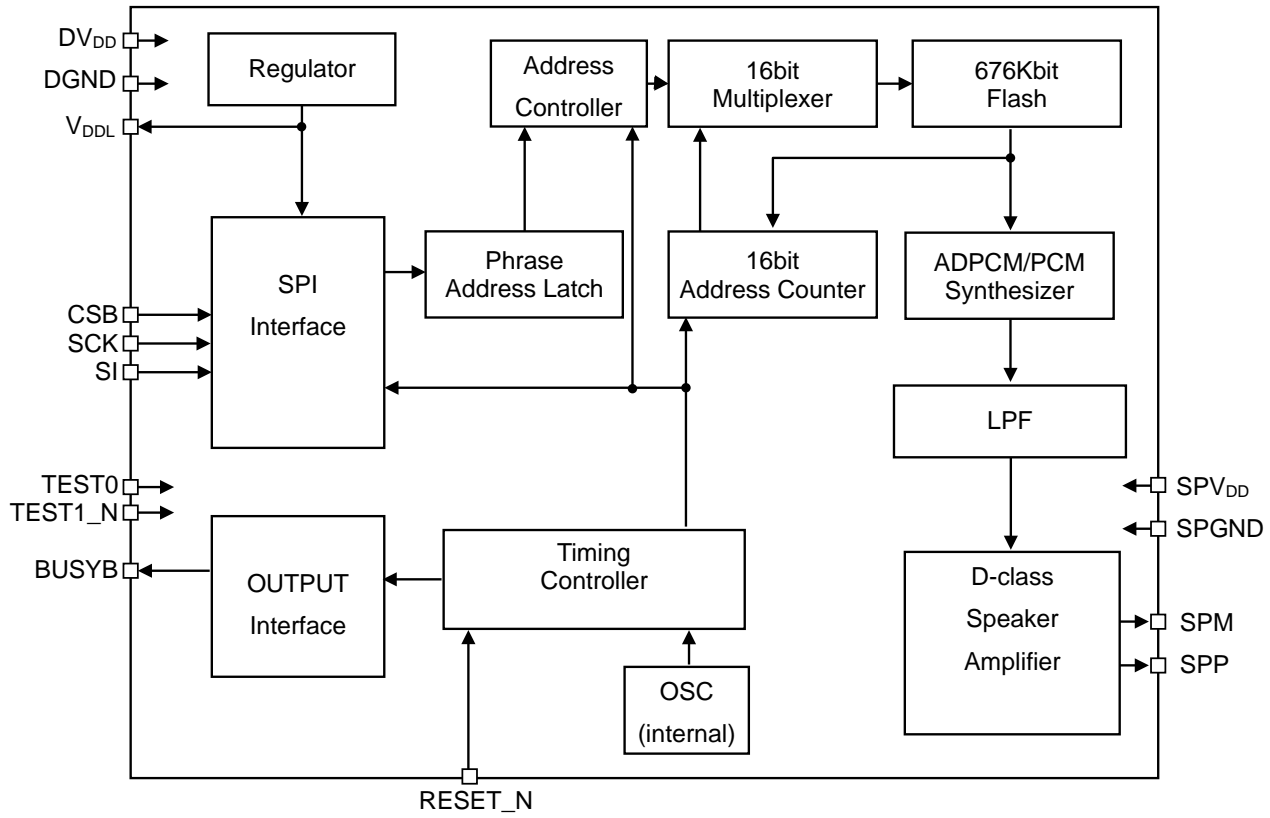

■ PIN CONFIGURATIONS (TOP VIEW)

20-Pin Plastic TSSOP

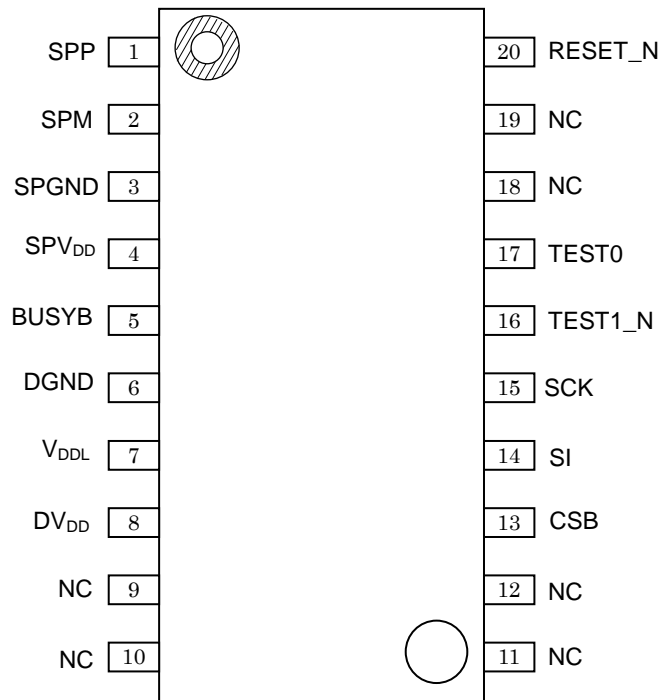

NC : Unused pin

■ PIN DESCRIPTION

Pin	Symbol	I/O	Initial value (At the RESET_N Input)	Initial value (At standby)	Description
1	SPP	O	Hi-Z	Hi-Z	Positive (+) output pin of the speaker amplifier built-in
2	SPM	O	Hi-Z	Hi-Z	Negative (-) output pin of the speaker amplifier built-in.
3	SPGND	-	-	-	Ground pin for the speaker amplifier.
4	SPV _{DD}	-	-	-	Power supply pin for the speaker amplifier Connect a bypass capacitor of 1 $\mu\text{F} \pm 30\%$ or more between this pin and SPGND pin.
5	BUSYB	O	Hi-Z	*1	BUSY output pin. When BUSYB use mode is set, the "L" level is outputted during playback. When disconnection is detected with disconnection detection function, and command processing in flash memory access mode, the "L" level is outputted. BUSYB unused mode and logic inversion can be set with Speech LSI Utility.
6	DGND	-	-	-	Digital ground pin.
7	V _{DDL}	-	-	-	Regulator output pin for internal logic circuitry. Connect a capacitor of 1 $\mu\text{F} \pm 30\%$ between this pin and DGND pin
8	DV _{DD}	-	-	-	Digital power supply pin. Connect a capacitor of 1 $\mu\text{F} \pm 30\%$ or more between this pin and DGND pin.
13	CSB	I	1	1	Chip select pin. Internal oscillation starts in response to turning "H" level down to "L" level, and input through Clock synchronization Serial interface becomes available. Pull-up resistor is built in.
14	SI	I	1	1	Input pin for Clock synchronization Serial interface data.
15	SCK	I	*1	*1	Input pin for Clock synchronization Serial interface clock. Initial value can be inverted by Speech LSI Utility.
16	TEST1_N	I	1	1	Input pin for testing. This pin has a pull-up resistor built in. Fix this pin to DV _{DD} .
17	TEST0	I/O	0	0	Input/output pin for testing. Leave this pin open.
20	RESET_N	I	0	1	Reset pin. Input "L" level for initialization, when power is turned on, or when voltage falls below recommended operation power supply voltage range. After the power supply voltage is stable, drive this pin to "H" level.
9 10 11 12 18 19	N.C.	-	-	-	Unused pin. Leave this pin open.

*1: This value depends on Speech LSI Utility setting. Please refer to a "Code Option Setting Item" for details.

■ ABSOLUTE MAXIMUM RATINGS

(DGND = SPGND = 0 V)

Parameter	Symbol	Condition	Rating	Unit
Power supply voltage	DV _{DD} SPV _{DD}	Ta = 25 °C	-0.3 to +6.5	V
Internal logic power supply voltage	V _{DDL}		-0.3 to +2.0	V
Input voltage	V _{IN}		-0.3 to V _{DD} +0.3	V
Power dissipation	P _D		1	W
Output short-circuit current	I _{SC1}	Applied to pin other than SPP or SPM	-12 to +11	mA
	I _{SC2}	SPP pin, SPM pin	600	mA
Storage temperature	T _{STG}	-	-55 to +150	°C

■ RECOMMENDED OPERATING CONDITIONS

(DGND = SPGND = 0 V)

Parameter	Symbol	Condition	Range	Unit
Power supply voltage	DV _{DD} SPV _{DD}	-	2.0 to 5.5	V
		Flash memory write	2.2 to 5.5	
Flash memory rewrite cycles ^{**1}	N	-	100	times
Operating temperature range	T _{OP1}	-	-40 to +85	°C
	T _{OP2}	Flash memory write	0 to +40	
Capacitor externally connected to DV _{DD} pin	C _V	-	1±30% or more	μF
Capacitor externally connected to SPV _{DD} pin	C _{SV}	-	1±30% or more	μF
Capacitor externally connected to V _{DDL} pin	C _L	-	1±30%	μF
FLASH Memory write cycle	Y _{DR}	-	15	years

^{**1}: It means one erase and one program. Even when erasing is interrupted, it counts as one time.

■ ELECTRICAL CHARACTERISTICS

● DC Characteristics

 $DV_{DD} = SPV_{DD} = 2.0 \text{ to } 5.5 \text{ V}, DGND = SPGND = 0 \text{ V}, Ta = -40 \text{ to } +85^{\circ}\text{C}$

Parameter	Symbol	Condition	Min.	Typ.	Max.	Unit
"H" input voltage	V_{IH}	-	$0.7 \times DV_{DD}$	-	DV_{DD}	V
"L" input voltage	V_{IL}	-	0	-	$0.3 \times DV_{DD}$	V
"H" output voltage 1	V_{OH1}	$I_{OH} = -0.5 \text{ mA}$	$DV_{DD} - 0.5$	-	-	V
"L" output voltage 1	V_{OL1}	$I_{OL} = 0.5 \text{ mA}$	-	-	0.5	V
"H" input current 1	I_{IH1}	$V_{IH} = DV_{DD}$	-	-	1	μA
"H" input current 2	I_{IH2}	$V_{IH} = DV_{DD}$ TEST0 pin	0.02	0.3	1.5	mA
"L" input current 1	I_{IL1}	$V_{IL} = DGND$	-1	-	-	μA
"L" input current 2	I_{IL2}	$V_{IL} = DGND$ RESET_N pin, TEST1_N	-1.5	-0.3	-0.02	mA
"L" input current 3	I_{IL3}	$V_{IL} = DGND$ CSB pin	-250	-30	-2	μA
"H" output current 1	I_{OOH1}	$VOH = DV_{DD} = SPV_{DD}$ (High impedance) BUSYB, SPP, SPM pin	-	-	1	μA
"H" output current 2	I_{OOH2}	$VOH = DV_{DD}$ (Nch Open drain) BUSYB pin	-	-	1	μA
"L" output current 1	I_{OOL1}	$VOL = DGND = SPGND$ (High impedance) BUSYB, SPP, SPM pin	-1	-	-	μA
"L" output current 2	I_{OOL2}	$VOL = DGND$ (Pch Open drain) BUSYB pin	-1	-	-	μA
Supply current during playback	I_{DD1}	No output load $DV_{DD} = SPV_{DD} = 3.0 \text{ V}$	-	3.0	6.0	mA
	I_{DD2}	No output load $DV_{DD} = SPV_{DD} = 5.0 \text{ V}$	-	5.0	9.0	
Supply current during stabilizing chattering	I_{DDC1}	$DV_{DD} = SPV_{DD} = 5.0 \text{ V}$	-	2.0	3.5	mA
Standby supply current	I_{DDs1}	$Ta \leq 50^{\circ}\text{C}$	-	0.5	3.0	μA
	I_{DDs2}	$Ta \leq 85^{\circ}\text{C}$	-	0.5	8.0	
Source oscillation frequency	f_{OSC}	-10 to +50 $^{\circ}\text{C}$	8.069	8.192	8.315	MHz
		-40 to +85 $^{\circ}\text{C}$	7.946	8.192	8.438	

● Characteristics of Analog Circuitry

 $DV_{DD} = SPV_{DD} = 2.0 \text{ to } 5.5 \text{ V}, DGND = SPGND = 0 \text{ V}, Ta = -40 \text{ to } +85^{\circ}\text{C}$

Parameter	Symbol	Condition	Min.	Typ.	Max.	Unit
SPM, SPP output load resistance	R_{LSP}	-	8	-	-	Ω
Speaker amplifier output voltage	P_{SPO}	$SPV_{DD} = 5.0 \text{ V}$, Sin wave $f = 1 \text{ kHz}$ $R_{LSP} = 8 \Omega$, THD $\geq 10\%$	-	1.0	-	W

● Power-on/Shutdown Sequence

 $DV_{DD} = SPV_{DD} = 2.0 \text{ to } 5.5 \text{ V}, DGND = SPGND = 0 \text{ V}, Ta = -40 \text{ to } +85^{\circ}\text{C}$

Parameter	Symbol	Condition	Min.	Typ.	Max.	Unit
RESET_N input pulse width at Power on	tr_{STR}	-	100	-	-	μs
RESET_N input pulse width at shut down	tr_{STF}	-	0	-	-	μs

- AC Characteristics

 $DV_{DD} = SPV_{DD} = 2.0 \text{ to } 5.5 \text{ V}, DGND = SPGND = 0 \text{ V}, T_a = -40 \text{ to } +85^\circ\text{C}$

Parameter	Symbol	Condition	Min.	Typ.	Max.	Unit
Initialization time after reset release	t_{INIT}	-	-	-	65	ms
SCK input enable time from CSB fall edge	t_{ESCK1}	Oscillation stop	2	-	-	ms
	t_{ESCK2}	Oscillating	10	-	-	μs
SCK hold time from CSB rise edge	t_{CSH}	-	200	-	-	ns
Data setup time from SCK rise edge	t_{DIS}	-	50	-	-	ns
Data hold time from SCK rise edge	t_{DIH}	-	50	-	-	ns
SCK cycle	t_{SCYC}	-	500	-	-	ns
SCK "H" level pulse width	t_{SCKH}	-	200	-	-	ns
SCK "L" level pulse width	t_{SCKL}	-	200	-	-	ns
Playback time	t_{VCYC}	-	20	-	-	ms
BUSYB change time from "H" to "L", after a command is inputted	t_{CB}	-	-	-	400	μs
CSB "H" level pulse width	t_{CSW}	-	1	-	-	ms
Oscillation stop time, after playback	t_{OSST}	-	-	-	500	μs
Next command transmit time□ In the case of the playback	t_{NCM}	-	-	-	10	ms
Disconnection judging by the DISCONNECT command start time	t_{DCDS}	-	1.5	-	-	ms
Disconnection judging by the DISCONNECT command end time	t_{DCDE}	-	-	-	1	s
BUSYB change time from "L" to "H", after over-current detection of a speaker amplifier	t_{SD}	-	-	-	80	μs
Processing time before playback start	t_{PLBF}	-	0.3	-	2.1	ms
Processing time after playback start	t_{PLAF}	-	0.15	-	1.2	ms
Fade-out time at Change Immediately mode or Change Immediately Once mode	t_{FDO}	-	-	22	-	ms

Note: Output pin load capacitance = 45 pF (max.)

- AC Characteristics (Flash memory access mode)

 $DV_{DD}=SPV_{DD}=2.2\sim 5.5V$, $DGND=SPGND=0V$, $T_a=0\sim +40^{\circ}C$

Parameter	Symbol	Condition	Min.	Typ.	Max.	Unit
BUSYB change time from "H" to "L", after a command is inputted	t_{FCB}	In Flash memory access mode	-	-	50	μs
Command execution time	t_{FCP}		-	-	15	μs
Flash memory erase time	t_{FER}		-	-	2.4	s
Checksum confirmation time	t_{FCS}		-	-	45	ms
Flash memory write verify processing time (256 bytes input)	t_{FWV}		-	-	9	ms
Flash memory verify time (256 bytes input)	t_{FV}		-	-	2.2	ms
Sound code data transmission interval	t_{FDI}		7	-	-	μs
CSB hold time after voice code data transmission	t_{FCSH}		7	-	-	μs
Wait time for accepting the next command after command processing	t_{FCE}		0	-	-	μs

Note: Output pin load capacitance = 45 pF (max.)

■ PLAYBACK FUNCTION

● Clock synchronization Serial interface data.

The CSB, SCK, SI pins are used to input the command data.

Driving the CSB pin from “H” to “L” level enables the serial MCU interface.

After the CSB pin becomes “L” level, the command is input through the SI pin from the MSB or LSB synchronized with the SCK clock. The command shifts in through the SI pin at the rising edge of the SCK clock pulse. Then, a command is executed at the rising edge of the eighth pulse of the SCK clock when 1-byte command is selected and the 16th pulse of the SCK clock when 2-byte command is selected.

After a command input, should return the CSB pin to "H" level.

The initial value of the SCK pin, MSB/LSB of the SI pin data input, and 1-byte command/2-byte command are all chosen with Speech LSI Utility.

Please refer to a "Code Option Setting Item" for details.

◆ Input timing when 1-byte command is selected

● Normal (“H” Level), MSB fast selected

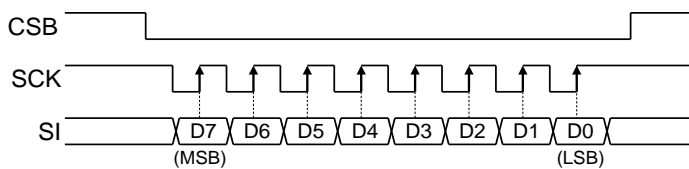

● Reversal (“L” Level), LSB fast selected

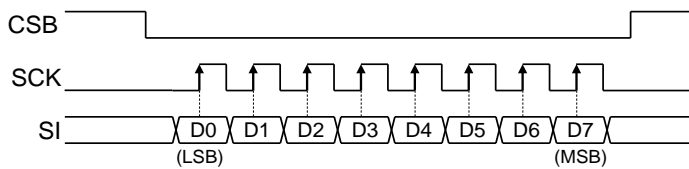

◆ Input timing when 2-byte command is selected

● Normal (“H” Level), MSB fast selected

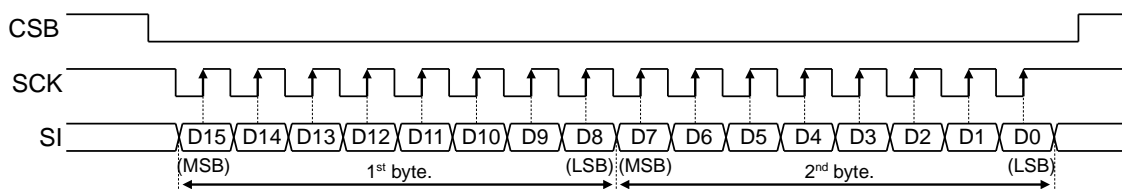

● Reversal (“L” Level), LSB fast selected

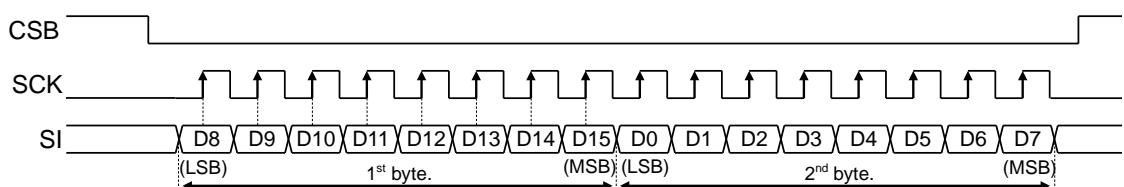

- Speech synthesis algorithm

Supporting four types of Speech Synthesis algorithms, which are HQ-ADPCM, 4bit ADPCM2, 8-bit nonlinear PCM, 8-bit Straight PCM, and 16-bit Straight PCM. Any of these can be selected based on the characteristics of the sound to be played back.

Speech Synthesis algorithm	Compression rate ^{*1}	Suitable waveform	Characteristics
HQ-ADPCM	1/5	Sound including high frequency components (such as sound effects)	4bit ADPCM2 algorithm is improved. Adopting variable bit length enables high sound quality and high data compression.
4-bit ADPCM2	1/4	Normal voice sound wave	Unique scheme which is a refined version of 4bit ADPCM Offers higher sound quality with better waveform followability.
8-bit Nonlinear PCM	1/2	Sound including high frequency components (such as sound effects)	A part around the center of the waveform is played back with a sound quality equivalent to 10 bits.
8-bit Straight PCM	1/2		Normal 8-bit Straight PCM.
16-bit Straight PCM	1		Normal 16-bit Straight PCM.

*1: When the same sampling frequency is used.

- Memory Allocation and Creating Sound code Data

The sound code data consists of a sound management area, a sound data area, and an edit ROM area.

The sound control area manages setting information of 30 phrases or 62 phrases.

The sound area contains actual waveform data.

The edit ROM area contains data for effective use of sound data. For the details, refer to the section of "Edit ROM Function". The edit ROM area only available when the edit ROM is used.

The ROM data is created using Speech LSI Utility.

The 30 or 62 phrases can be switched using the Speech LSI Utility.

Please refer to a "Code Option Setting Item" for details.

Sound code data configuration (30 phrase selection)

0x00000	Sound control area
0x001FF	
0x00200	
0x153FF	Sound data area / Edit ROM area ^{*1}

Sound code data configuration (62 phrase selection)

0x00000	Sound control area
0x003FF	
0x00400	
0x153FF	Sound data area / Edit ROM area ^{*1}

*1: Edit ROM area depends on creation of the data

- Playback Time and Flash Capacity

The playback time depends on the memory capacity, sampling frequency, and the playback method. The equation to know the playback time is shown below. But this is not applied if the edit ROM function is used.

$$\text{Playback time [sec]} = \frac{1.024 \times (\text{Voice data area/Edit ROM area}) (\text{Kbit})}{\text{Sampling frequency [kHz]} \times \text{Bit length}}$$

(Bit length is 3.2 at the HQ-ADPCM, 4 at the 4-bit ADPCM2 and 8/16 at the PCM.)

In the case that the sampling frequency is 8 kHz, algorithm is HQ-ADPCM, the playback time is as follows.

When 30 phrases are selected

$$\text{Playback time} = \frac{1.024 \times 676 (\text{Kbit})}{8 (\text{kHz}) \times 3.2 (\text{bit})} \approx 27.0 [\text{sec}]$$

When 62 phrases are selected

$$\text{Playback time} = \frac{1.024 \times 672 (\text{Kbit})}{8 (\text{kHz}) \times 3.2 (\text{bit})} \approx 26.9 [\text{sec}]$$

Make the playback time of one phrase more than 20 msec.

- Edit ROM function

The edit ROM function makes it possible to play back multiple phrases in succession. The following functions are set using the edit ROM function:

- Continuous playback: There is no limit to set the number of times of the continuous playback. It depends on the Flash capacity only.
- Silence insertion function: 4 ms to 1,024 ms
 *Note: Silent insertion time varies for ± 1 ms depends on the sampling frequency.
 An independent phrase generated by edit ROM shall be 20 ms or longer.

It is possible to use sound ROM effectively to use the edit ROM function.
 An example of the ROM structure, in a case of using the edit ROM function is as follows.

Example 1) Phrases using the Edit ROM Function

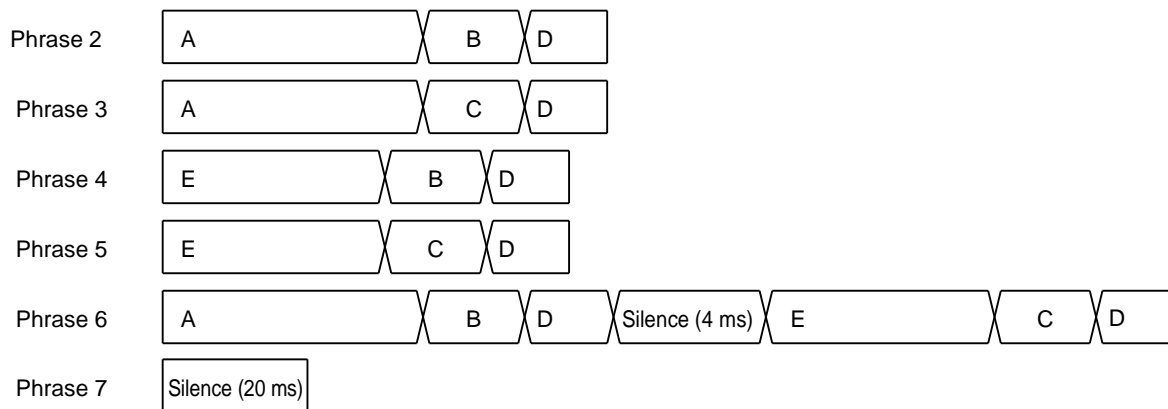

Example 2) Structure of the ROM storing contents of Example 1 (When 30 phrases are selected)

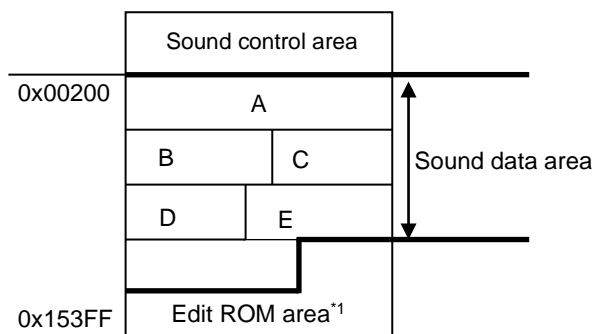

*1 : Information on phrases 2 to 7 stored

• Playback mode setup

Five playback modes are available. Can be set up for every phrase.
Set when the sound code data is generated.

◆ Play Once mode

This mode is playback once.
All the commands become invalid during playback.

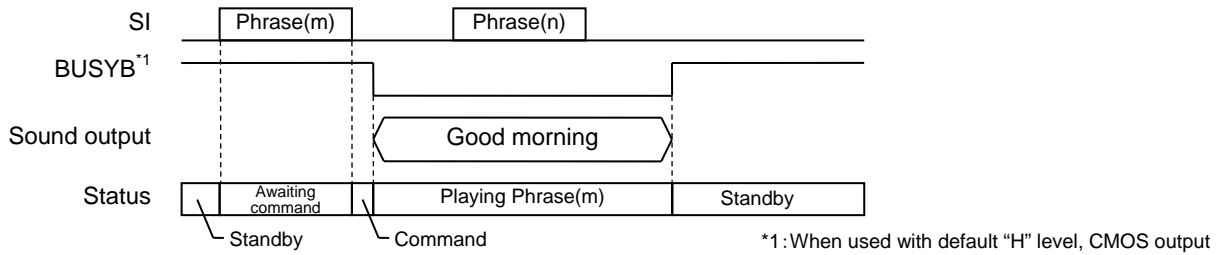

Next command must be input in the standby state after the playback ends.

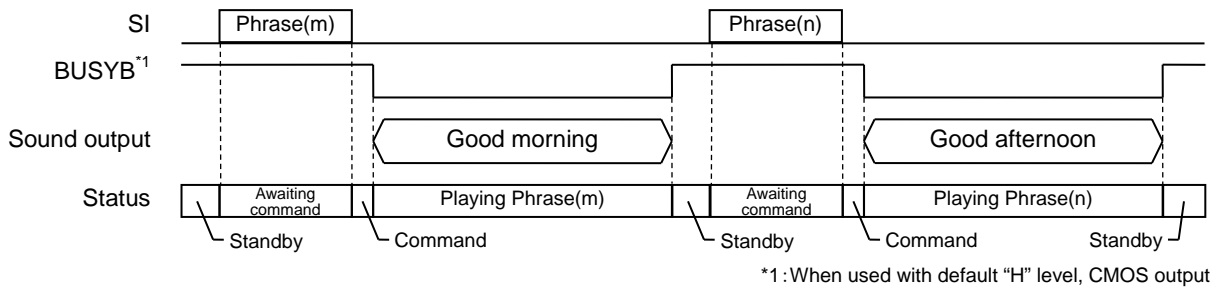

◆ Scheduled Play Once mode

This mode is playback once.
When the next command is inputted during playback, after playback of the present phrase ends, playback of the next command starts.

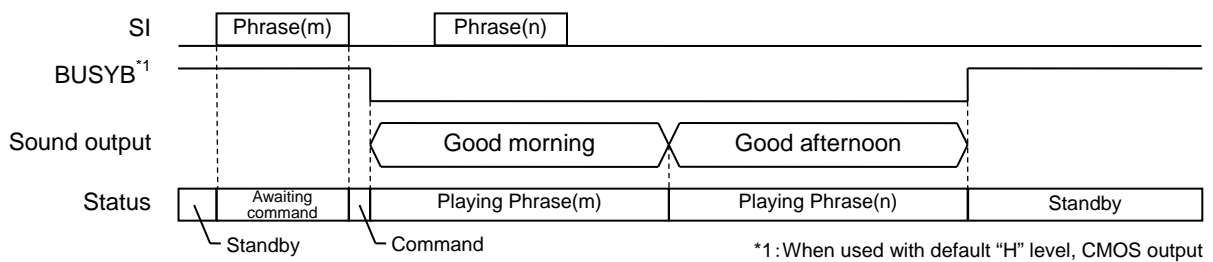

When a plurality of commands are inputted, the last command input at the end of the command is valid.
In the following case, the phrase (n) is not played back because the last command is STOP command.

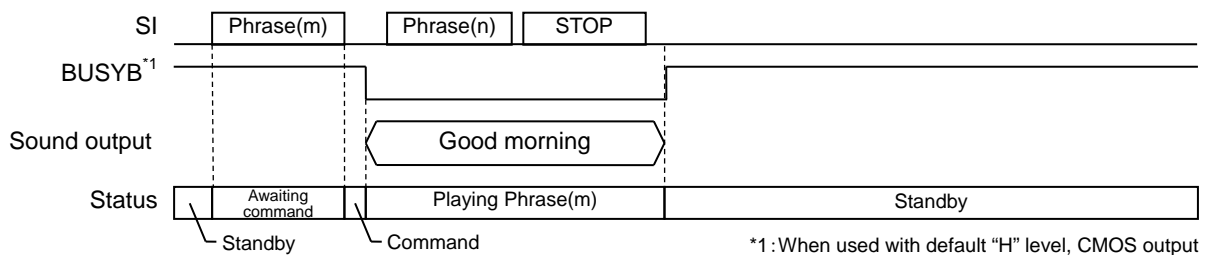

◆ Change Immediately Once mode

This mode is for playing back once.

When the following phrase is inputted into playback, playback of the present phrase is ended on the way, and playback of the following phrase starts.

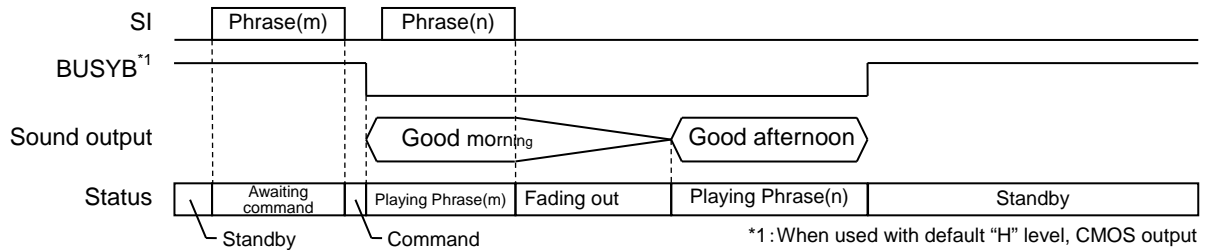

When a plurality of commands are inputted, the last command input at the end of the phrase is valid.

In the following case, the last input phrase (o) is played back.

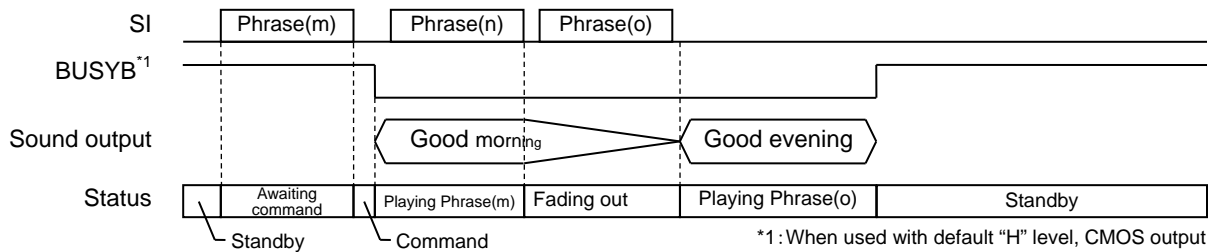

◆ Scheduled Play mode

Once the playback starts, it is repeated until the next command is input.

The next command input during the playback is executed after the playback ends.

When a plurality of commands are inputted, the last command input at the end of the phrase is valid, as in Scheduled Play Once.

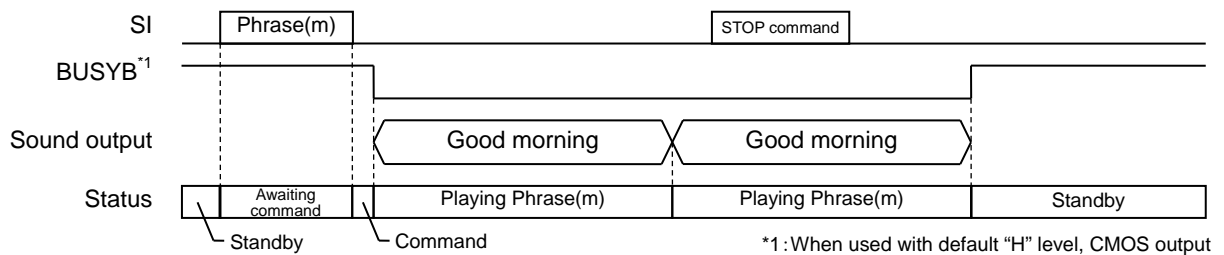

◆ Change Immediately mode

Once the playback starts, it is repeated until the next command is input.

When the next command is inputted, the phrase being played back is terminated, and the next command is executed.

When a plurality of commands are inputted, the last command input at the end of the phrase is valid, as in Change Immediately Once.

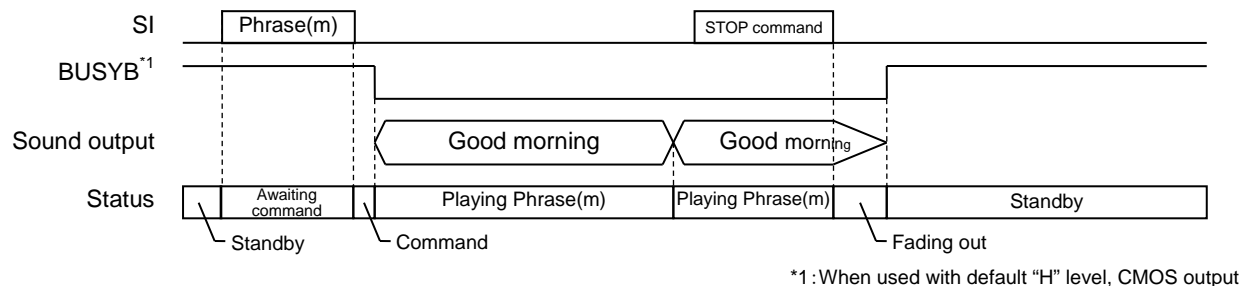

● Volume setup function

Each phrase can set up the volume setup.

The volume is set when sound code data is generated and when PHRASE command is input.

For the setting of volume when PHRASE command is input, refer to “PHRASE command” in Description of Command Functions.

The relationship between the setting and volume at the time of generating sound code data is as follows.

Value	Volume [dB]	Value	Volume [dB]	Value	Volume [dB]
00h	+2.98	0Ah	-0.41	15h	-6.87
01h	+2.70	0Bh	-0.83	16h	-7.79
02h	+2.40	0Ch	-1.28	17h	-8.82
03h	+2.10	0Dh	-1.75	18h	-9.99
04h	+1.78	0Eh	-2.25	19h	-11.34
05h	+1.45	0Fh	-2.77	1Ah	-12.94
06h	+1.11	10h	-3.34	1Bh	-14.90
07h	+0.76	11h	-3.94	1Ch	-17.44
08h	+0.39	12h	-4.58	1Dh	-21.04
09h	+0.00	13h	-5.28	1Eh	-27.31
		14h	-6.04	1Fh	OFF

- Function of setting wait time before and after playback (WS1, WS2, WS3, WS4)

Wait time before playback (WS1, WS2) and after playback (WS3, WS4) can be set for each phrase.

Set when the sound code data is generated.

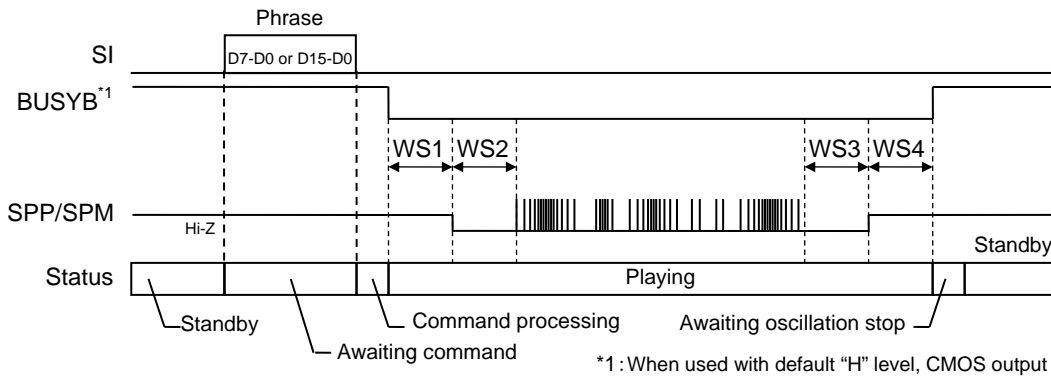

WS1: Time after inputting a phrase address, until SPP/SPM pins are enabled.

WS2: Time after SPP/SPM pins are enabled, until playback is started.

WS3: Time after playback is completed, until SPP/SPM pins are disabled.

WS4: Time after SPP/SPM pins are disabled, until it will be in a standby state.

WS1-WS4 can be arbitrarily set up between 0 to 1020 ms (4 ms unit).

• Speaker Pin Short Detection Function

The speaker pin short detection function detect the short-circuit between SPP pin and SPM pin, or between SPP/SPM pin and GND during playback.

When short-circuit of a speaker pin is detected, the playback will be stopped automatically, BUSYB pin will become "H" level, and LSI will become in a standby state.

Speaker short detection prevents IC destruction, but the detection circuit is effective to prevent destruction caused by sudden accidents, and is not intended for use in the condition like short detection occurs continuously.

This function can be set up with the option screen of Speech Utility.

Please refer to a "Code Option Setting Item" for details.

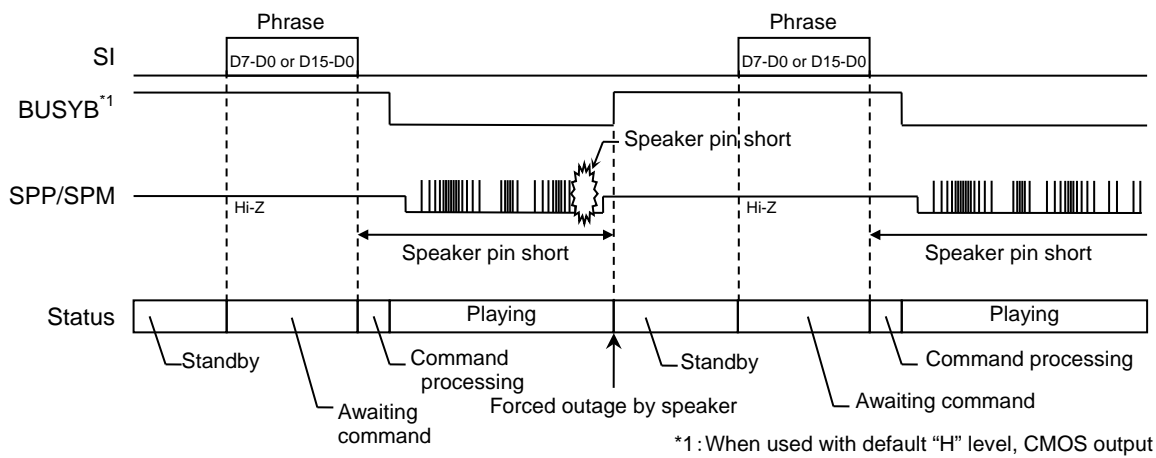

■ PLAYBACK COMMANDS

● Playback Commands List

The following playback commands are used for the LSI. Use the playback commands in the condition ensuring that the sound code data is set on the flash memory of this LSI.

Command	Description
STOP	Stop command. The STOP command becomes effective for phrase other than those in Play Once mode and Scheduled Play Once mode.
DISCONNECT	Disconnection detection command. Speaker disconnection is detected. The STOP command must be input after using the DISCONNECT command.
PHRASE	Playback command. Playback phrase is selected from 30 phrases.

● Playback Commands configuration

1-byte command and 2-byte command can be selected.

When the 2-byte command is selected, the volume can be expanded to 32 levels and the number of phrases can be expanded to 62 phrases.

PHRASE command is allocated with a bit sequence other than the set values for STOP command and DISCONNECT command.

These are set when the sound code data is generated.

Please refer to a "Code Option Setting Item" for details.

The command configuration when the initial value (STOP command is set to be 00b and DISCONNECT command is set to be 01b) is as follows.

(1) 1-byte command (8 levels of volume and 30 phrases)

Command	First byte							
	D7	D6	D5	D4	D3	D2	D1	D0
STOP	0	0	0	0	0	0	0	0
DISCONNECT	0	0	0	0	0	0	0	1
PHRASE	V2	V1	V0	0	0	0	1	0
	:							
	V2	V1	V0	1	1	1	1	1

(2) 2-byte command (initial value: 32 levels of volume and 62 phrases)

Command	First byte								Second byte							
	D15	D14	D13	D12	D11	D10	D9	D8	D7	D6	D5	D4	D3	D2	D1	D0
STOP	0	0	0	0	0	0	0	0	0	0	0	0	0	0	0	0
DISCONNECT	0	0	0	0	0	0	0	0	0	0	0	0	0	0	0	1
PHRASE	0	0	0	V4	V3	V2	V1	V0	0	0	0	0	0	0	1	0
	:								:							
	0	0	0	V4	V3	V2	V1	V0	0	0	1	1	1	1	1	1

Any bit sequence can be set for STOP command and DISCONNECT command.

The following shows examples of a case where a non-initial value is set.

When STOP command is changed from the initial value, the number of phrase available decreases by one.

(1) 1-byte command (when STOP command is set to be 1Fh and DISCONNECT command is set to be 01h)

Command	First byte							
	D7	D6	D5	D4	D3	D2	D1	D0
*1	0	0	0	0	0	0	0	0
DISCONNECT	0	0	0	0	0	0	0	1
PHRASE	V2	V1	V0	0	0	0	1	0
	:							
	V2	V1	V0	1	1	1	1	0
STOP	0	0	0	1	1	1	1	1

*1: 00h cannot be set to PHRASE command. 29 phrases from 02h to 1Eh can be set to PHRASE command.

(2) 2-byte command (when STOP command is set to be 3Eh and DISCONNECT command is set to be 02h)

Command	First byte								Second byte							
	D15	D14	D13	D12	D11	D10	D9	D8	D7	D6	D5	D4	D3	D2	D1	D0
*1	0	0	0	0	0	0	0	0	0	0	0	0	0	0	0	0
PHRASE	0	0	0	0	0	0	0	0	0	0	0	0	0	0	0	1
DISCONNECT	0	0	0	0	0	0	0	0	0	0	0	0	0	0	1	0
PHRASE	0	0	0	V4	V3	V2	V1	V0	0	0	0	0	0	0	1	1
	0	0	0	V4	V3	V2	V1	V0	0	0	:					
	0	0	0	V4	V3	V2	V1	V0	0	0	1	1	1	1	0	1
STOP	0	0	0	0	0	0	0	0	0	0	1	1	1	1	1	0
PHRASE	0	0	0	V4	V3	V2	V1	V0	0	0	1	1	1	1	1	1

*1: 00h cannot be set to PHRASE command. 61 phrases of 01h, from 03h to 3Dh and 3Fh can be set to PHRASE command.

• STOP command

(1) 1-byte command selection (initial value)

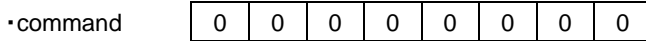

(2) 2-byte command selection (initial value)

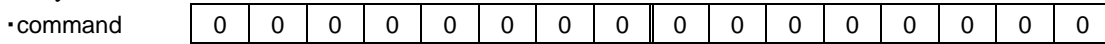

*: Since it is a bit that is not used to identify the command, it can be set to any value.

The STOP command is used to stop the playback. BUSYB pin will become “H”, if the playback is stopped. The STOP command becomes effective for the phrase waiting to be played in Scheduled Play Once mode, and in Scheduled Play modem, Change Immediately Once mode, and Change Immediately mode. STOP command used for phrases played back in Play Once mode or Scheduled Play Once mode, the STOP is ignored. When STOP command is input in Scheduled Play mode, the playback stops after the phrase is played back to the end. When STOP command is input in Change Immediately Once mode or Change Immediately mode, the sound fades out, and the playback stops.

Operations where STOP command is effective are described below.

◆ STOP command operation in the case of Scheduled Play Once mode

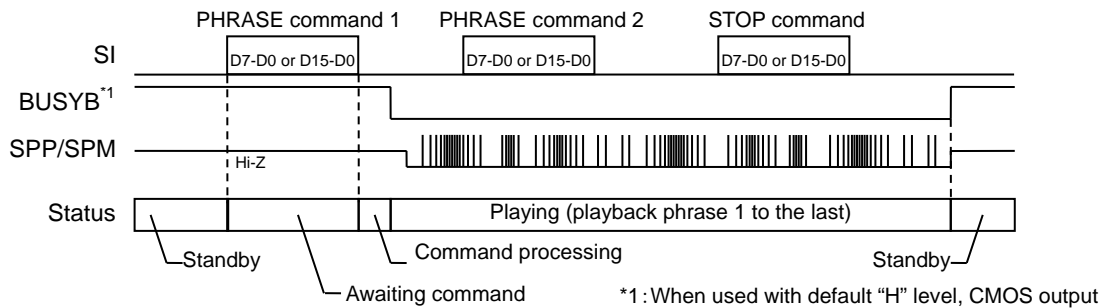

◆ STOP command operation in the case of Scheduled Play mode

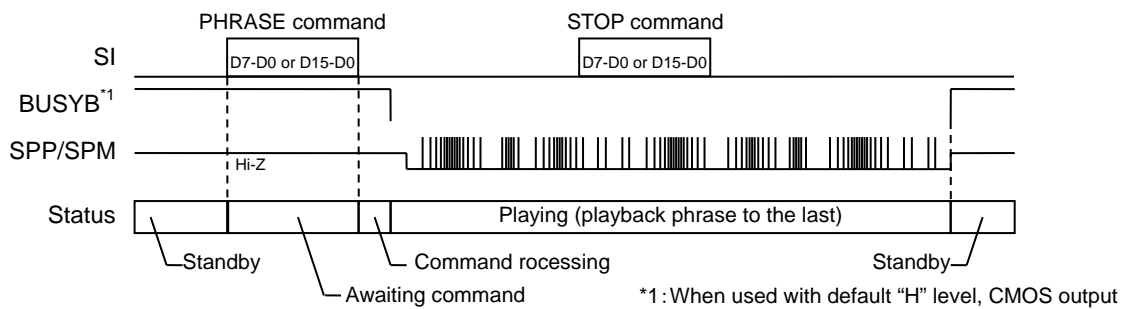

◆ STOP command operation in the case of Change Immediately Once mode or Change Immediately mode

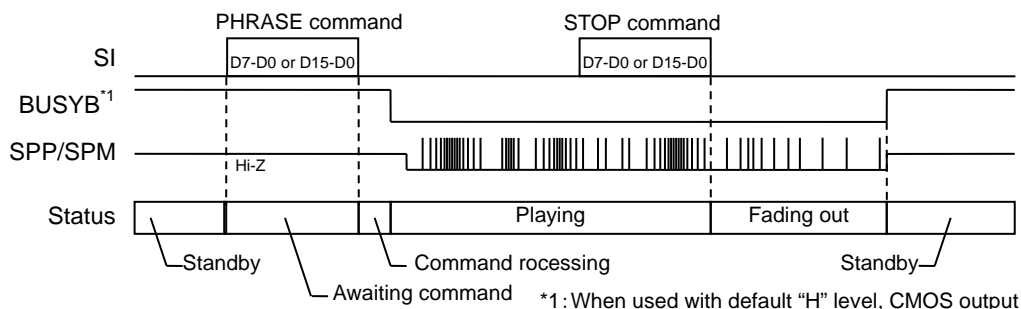

• DISCONNECT command

(1) 1-byte command selection (initial value)

•command

0	0	0	0	0	0	0	0	1
---	---	---	---	---	---	---	---	---

(2) 2-byte command selection (initial value)

•command

0	0	0	0	0	0	0	0	0	0	*	*	0	0	0	0	0	0	1
---	---	---	---	---	---	---	---	---	---	---	---	---	---	---	---	---	---	---

*: Since it is a bit that is not used to identify the command, it can be set to any value.

The DISCONNECT command is used to diagnose whether the speaker is disconnected or not. The command cannot be used during sound playback. The command shall be used during standby (no playback). Disconnection detection result is output to BUSYB pin. "L" is output when the speaker is disconnected, and outputs "H" when the speaker is not disconnected. Please input the STOP command to transition to standby state, after you use the DISCONNECT command.

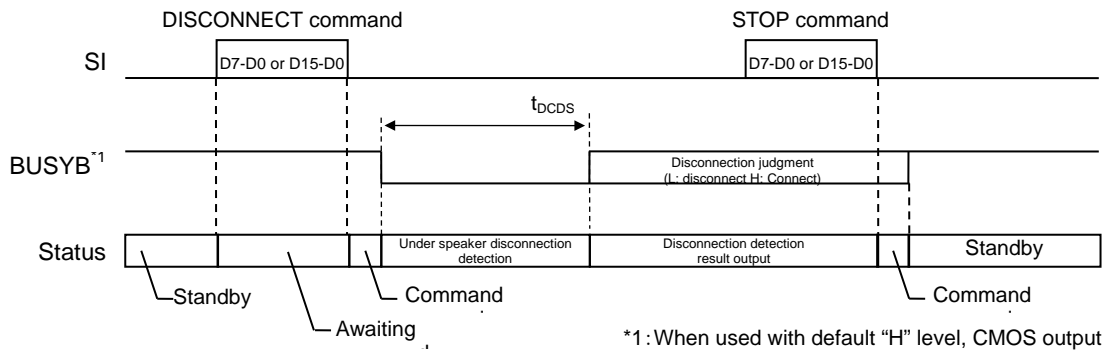

When no STOP command is input after the execution of DISCONNECT command, the disconnection detection automatically stops in one second, and transition to standby occurs.

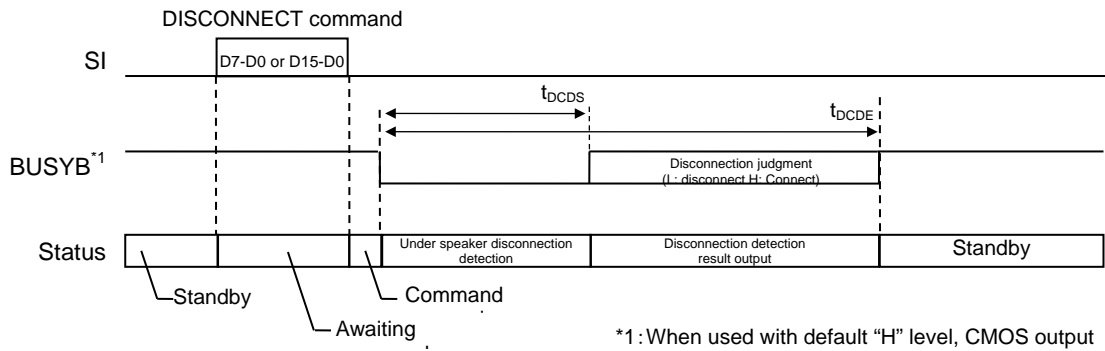

● PHRASE command

(1) 1-byte command selection

·command	V2	V1	V0	F4	F3	F2	F1	F0
----------	----	----	----	----	----	----	----	----

(2) 2-byte command selection

·command	0	0	0	V4	V3	V2	V1	V0	0	0	F5	F4	F3	F2	F1	F0
----------	---	---	---	----	----	----	----	----	---	---	----	----	----	----	----	----

*: Since it is a bit that is not used to identify the command, it can be set to any value.

PHRASE command is playback command. Specifies an address of a phrase to be played back. Command that is not set to be STOP command or DISCONNECT command is set to be PHRASE command. An address of phrase to be played back is set when sound code data is generated with Speech LSI Utility.

Timings of PHRASE command are shown below.

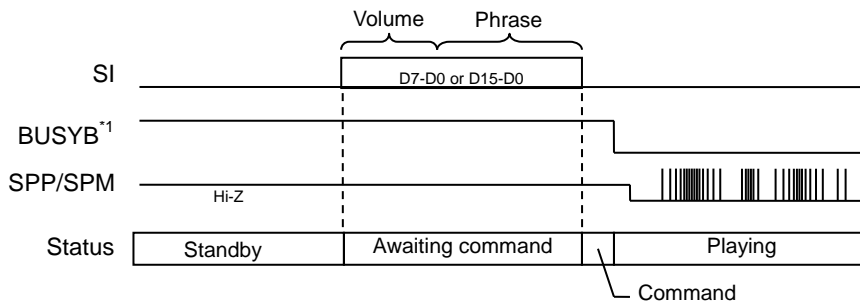

*1: When used with default "H" level, CMOS output

Set the playback Phrase with F4-F0 or F5-F0.

① 1-byte command selection (initial value)

No.	F4	F3	F2	F1	F0	Playing Phrase
1	0	0	0	1	0	Phrase 2
:	:					:
30	1	1	1	1	1	Phrase 1F

② 2-byte command selection (initial value)

No.	F5	F4	F3	F2	F1	F0	Playing Phrase
1	0	0	0	0	1	0	Phrase 2
:	:						:
62	1	1	1	1	1	1	Phrase 3F

The volume can be set up with V2-V0 or V4-V0 set.

This is used to playback sound with a volume other than one set when the sound code data is generated.

(1) When 1-byte command is selected.

V2	V1	V0	Volume [dB]
0	0	0	Volume set at the time of generating sound code data is used ^{*1}
0	0	1	+2.98
0	1	0	+1.78
0	1	1	0
1	0	0	-2.25
1	0	1	-5.28
1	1	0	-9.99
1	1	1	-21.04

*Note 1: For edited phrase, volume set for each registered phrase is used

(2) When 2-byte command is selected.

V4	V3	V2	V1	V0	Volume [dB]	V4	V3	V2	V1	V0	Volume [dB]
0	0	0	0	0	+2.98	1	0	0	0	0	-3.34
0	0	0	0	1	+2.70	1	0	0	0	1	-3.94
0	0	0	1	0	+2.40	1	0	0	1	0	-4.58
0	0	0	1	1	+2.10	1	0	0	1	1	-5.28
0	0	1	0	0	+1.78	1	0	1	0	0	-6.04
0	0	1	0	1	+1.45	1	0	1	0	1	-6.87
0	0	1	1	0	+1.11	1	0	1	1	0	-7.79
0	0	1	1	1	+0.76	1	0	1	1	1	-8.82
0	1	0	0	0	+0.39	1	1	0	0	0	-9.99
0	1	0	0	1	+0.00	1	1	0	0	1	-11.34
0	1	0	1	0	-0.41	1	1	0	1	0	-12.94
0	1	0	1	1	-0.83	1	1	0	1	1	-14.90
0	1	1	0	0	-1.28	1	1	1	0	0	-17.44
0	1	1	0	1	-1.75	1	1	1	0	1	-21.04
0	1	1	1	0	-2.25	1	1	1	1	0	-27.31
0	1	1	1	1	-2.77	1	1	1	1	1	Volume set at the time of generating sound code data is used ^{*1}

*Note 1: For edited phrase, volume set for each registered phrase is used

■ Flash memory access function by MCU interface

By sending dedicated commands to this function through the MCU interface, the following can be executed^{*1,*2}.

- Rewriting the sound code data in the Built-in flash memory.
- Verifying the sound code data in the Built-in flash memory.
- Checking the sound code data version^{*3}.

This function always rewrites and verifies data from the start data. Cannot be specified as any address. Also, data in the flash memory cannot be directly referenced.

● Flow of Flash memory access function by MCU interface

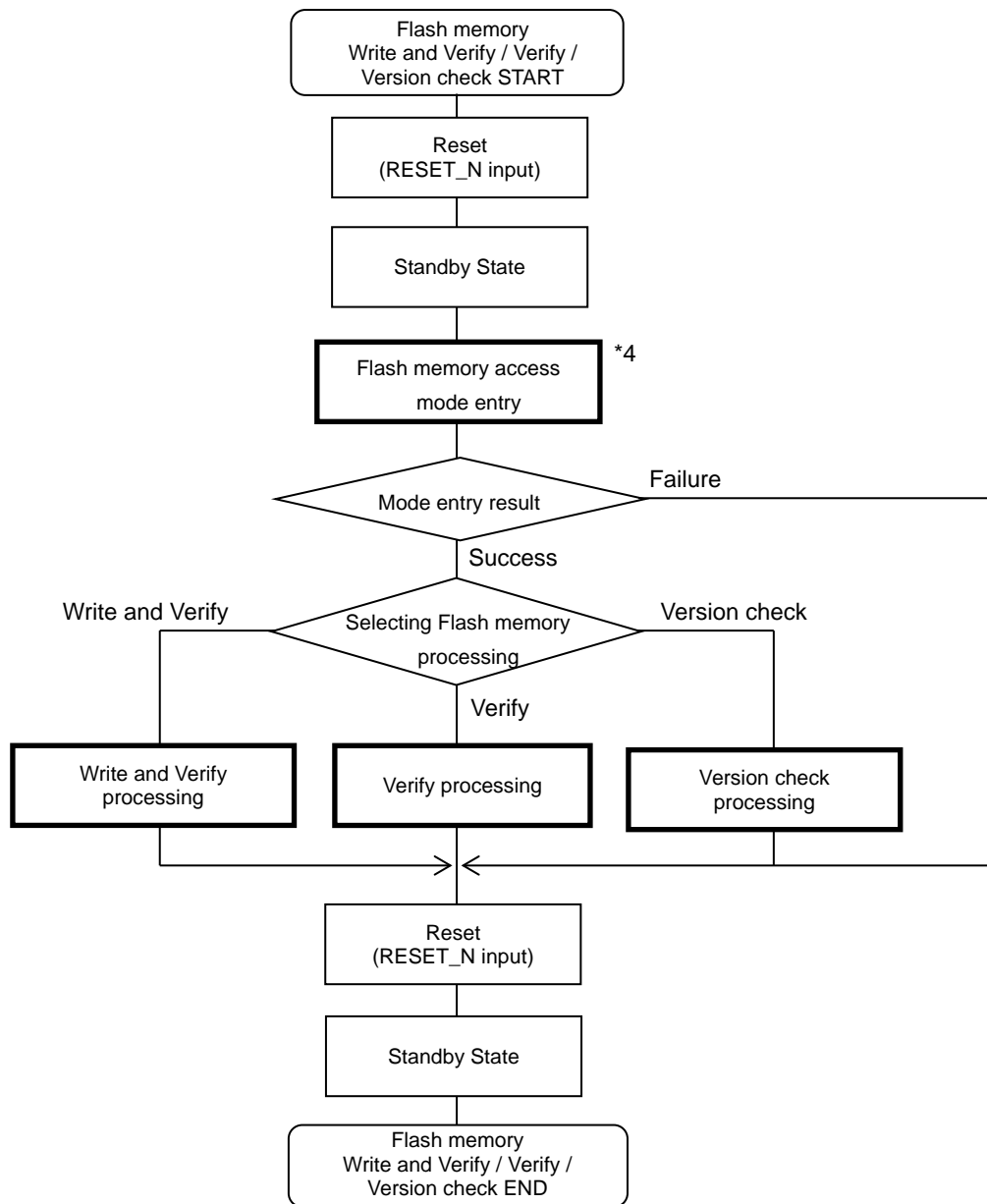

*Note 1: This function should be used under the conditions of $DV_{DD}=2.2$ to 5.5V and $T_a=0$ to +40°C.

*Note 2: The sound playback function cannot be used while this function is in use.

*Note 3: The code option information in the sound code data is reflected when the flash memory is rewritten, reset is input once, and initialization is performed. When checking the version of the new code data, execute it after initialization.

*Note 4: Detailed processing flow is shown on the later page for in the flow.

- Flow of Flash memory access function by MCU interface

The flash memory access function is controlled using the following dedicated commands.

Flash memory processing	Command name	Command value		Description
		1st byte	2nd byte	
Flash memory access mode entry	FLASH_ACCESS	1Fh	00h	Flash memory access mode command: This command can be input only for the first time after this reset. To cancel Flash memory access mode, input a reset.
	ACCESS_CODE	C0h	Access Code ^{*1}	Access code input command: When the access code input in the second byte matches the access code in the flash memory, entry to the flash memory access mode is completed.
Write and Verify or Verify	ERASE	A0h	40h	Flash memory erase command: After this command is input, the contents of the flash memory are erased. Rewrite the sound code data with the contents of the flash memory erased by this command. ^{*3}
	WRITE_VERIFY	80h	40h	Write and verify mode entry command: After this command is input, write and verify the input code simultaneously by setting CSB to L, continuously inputting the sound code data in even byte units, and then returning CSB to H. Up to 256 bytes can be input at a time.
	WRITE_END	80h	C0h	Write and verify mode exit command.
	VERIFY	60h	C0h	Verify mode entry command: After this command is input, verify the input code simultaneously by setting CSB to L, continuously inputting the sound code data in even byte units, and then returning CSB to H. Up to 256 bytes can be input at a time.
	VERIFY_END	60h	C0h	Verify mode exit command.
	CHECKSUM	Upper Byte	Lower Byte	Checksum command: The checksum of rewritten sound code data can be checked by inputting this command after inputting the WRITE_END or VERIFY_END commands.
Version check	CHECK_VER	40h	Version Code ^{*1}	Version check command: It is possible to check that the code input in the second byte matches the sound code data version in the flash memory.

*Note 1: Access Code and Version Code can be set up with the option screen of Speech Utility. Please refer to a "Code Option Setting Item" for details.

*Note 2: The checksum is the lower 16 bits of the sum of 8-bit units of the sound code data. In the .inf-file generated by Speech LSI Utility, the checksum information of the created sound code data is displayed.

*Note 3: After the flash memory is erased, use the playback commands in the condition ensuring that the sound code data is set on the flash memory of this LSI.

- Checking the processing status and results of control commands by BUSYB

The status and results of flash memory access control commands can be checked with BUSYB.

If the processing of each command fails, or if processing that deviates from the described processing flow is executed, BUSYB may not return to the default state even if each command execution time is passed. In that case, enter reset and try again from the flash memory access mode entry.

For the processing time of each command, see the timing chart for flash memory access mode and AC characteristics of electrical characteristics (flash memory access mode).

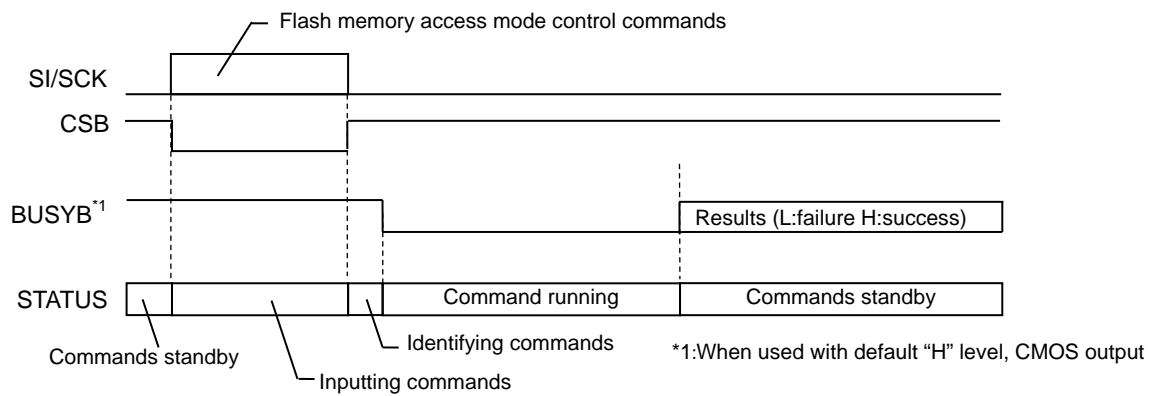

- Flow of Flash memory access mode entry processing

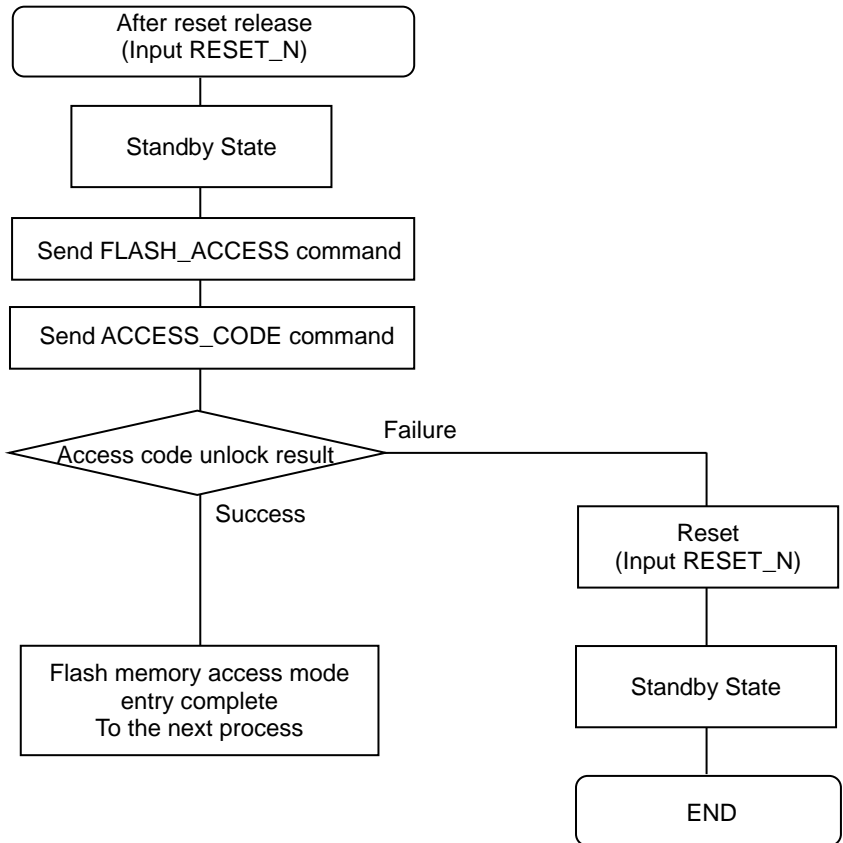

- Flow of "Write and verify" or "Verify" processing

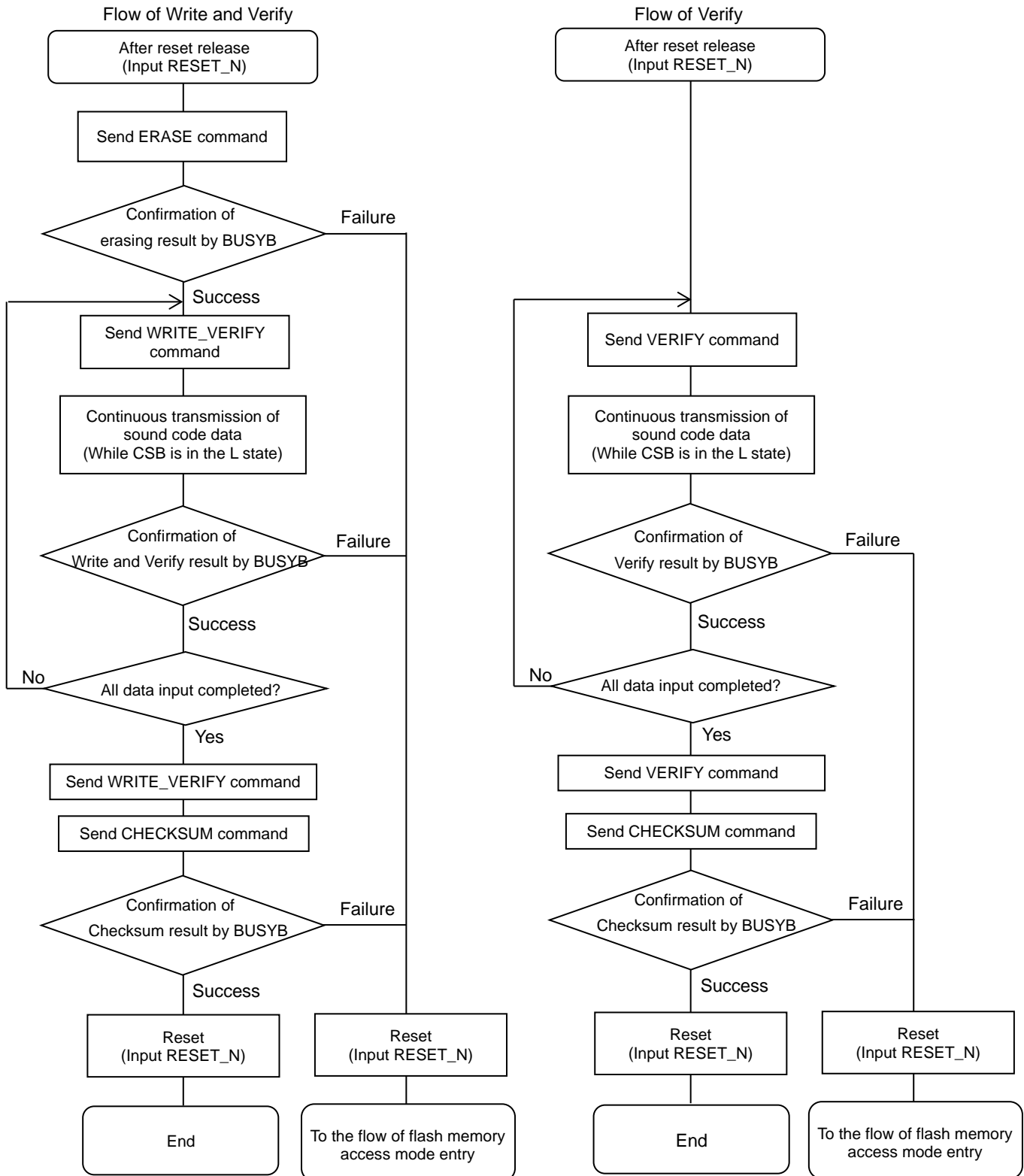

- Flow of Version check processing

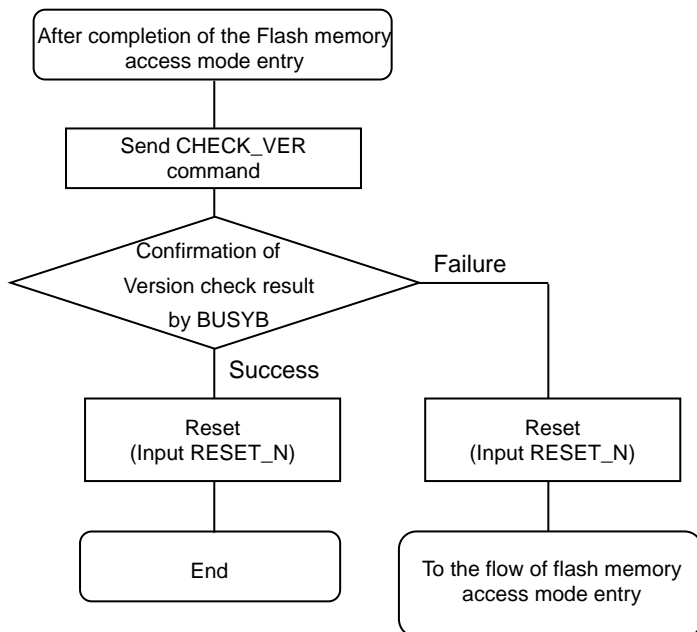

■ TIMING DIAGRAMS

● Power-On Timing

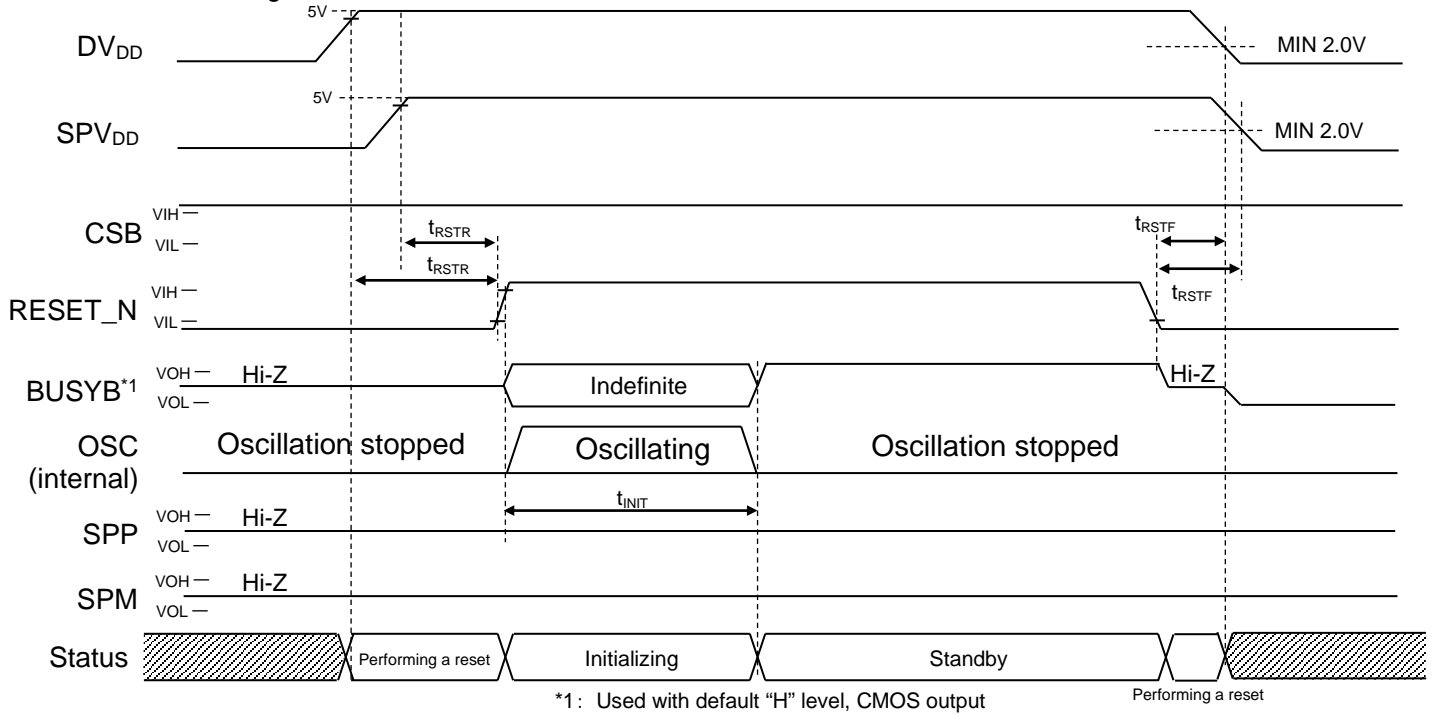

When the power is turned on and off, there is no restriction on the order of turning on DV_{DD} and SPV_{DD} . When DV_{DD} or SPV_{DD} falls below recommended operation power supply voltage range, "L" level must be input to $RESET_N$ pin.

● Power down timing (RESET_N pin)

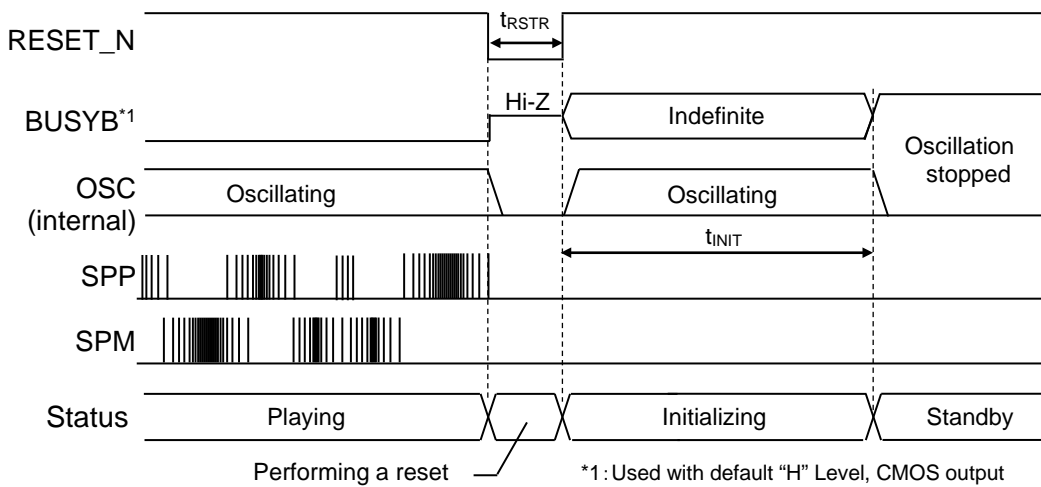

When DV_{DD} or SPV_{DD} falls below recommended operation power supply voltage range, "L" level must be input to $RESET_N$ pin.

• Clock synchronization Serial interface timing

◆ When 1-byte command is selected.

(When Normal (“H” level) is selected: SCK initial value is “H” level)

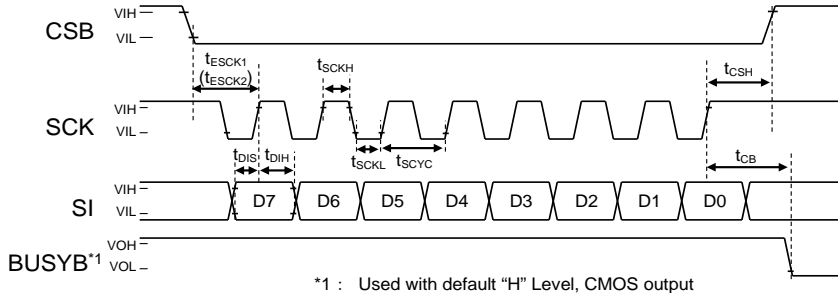

(When Reversal (“L” level) is selected: SCK initial value is “L” level)

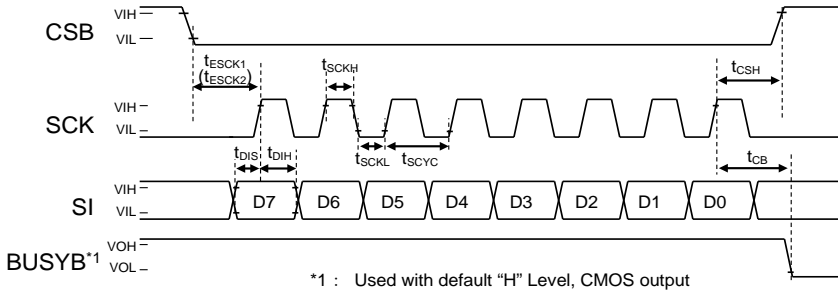

◆ When 2-byte command is selected.

(When Normal (“H” level) is selected: SCK initial value is “H” level)

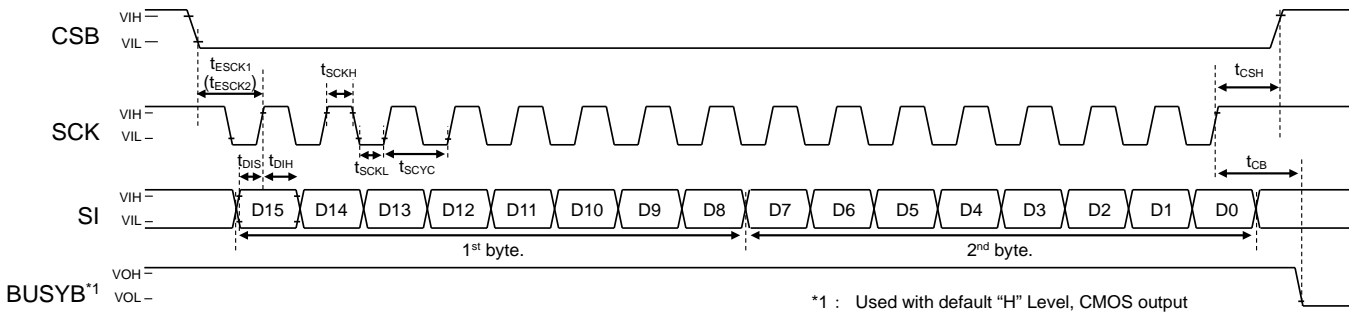

(When Reversal (“L” level) is selected: SCK initial value is “L” level)

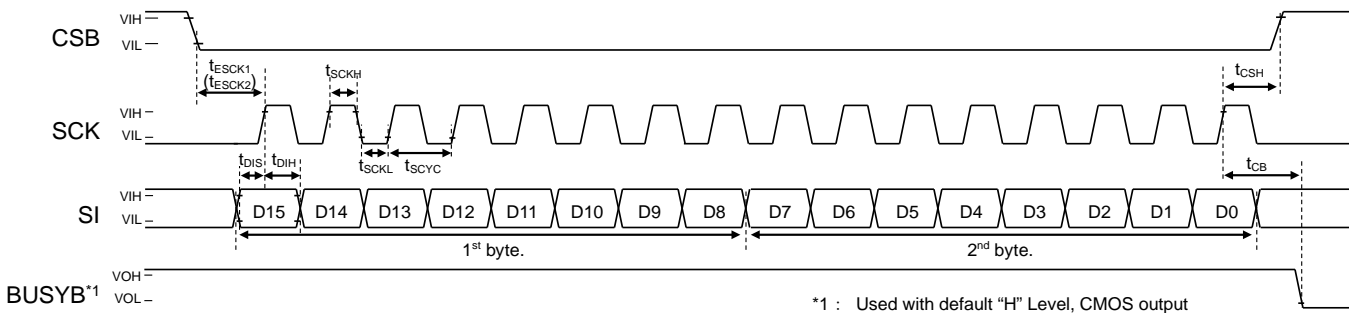

• Play Once/Scheduled Play Once/Change Immediately Once mode timing

After playback of phrase (m) ends, playback request for next phrase (n) is accepted and the phrase (n) is played back. All the commands become invalid during playback of phrase (m).

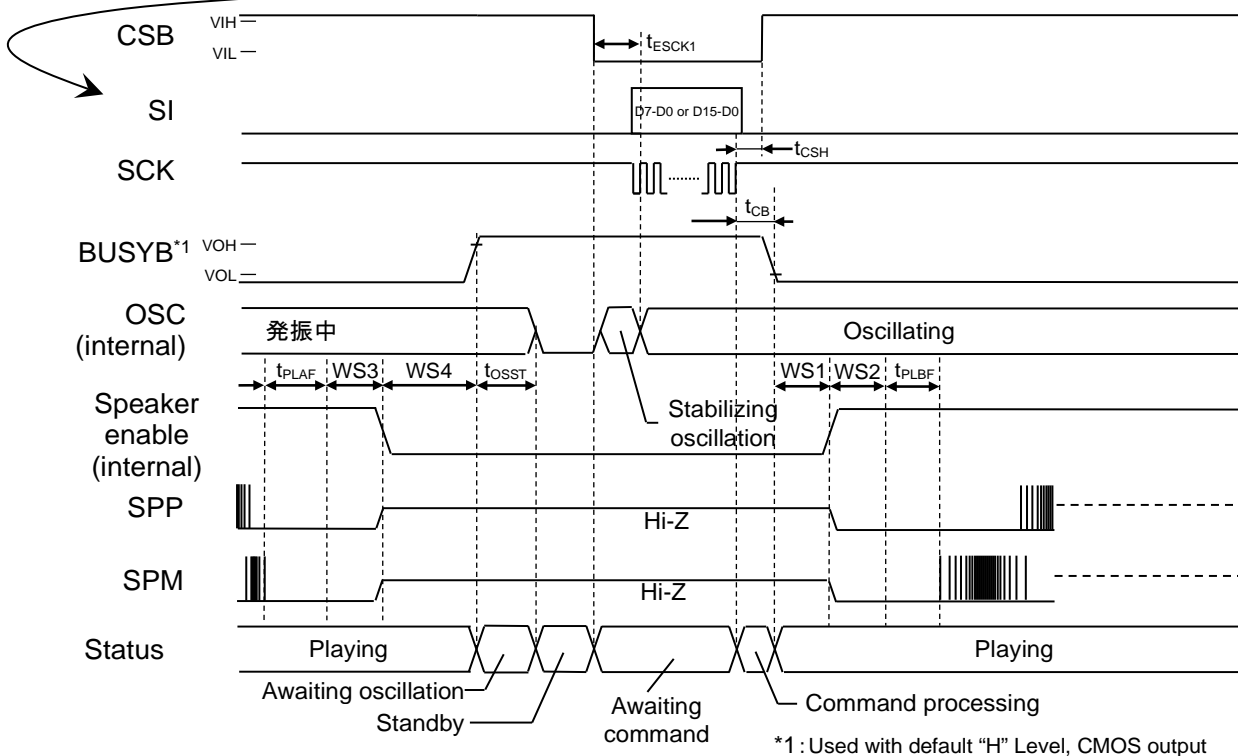
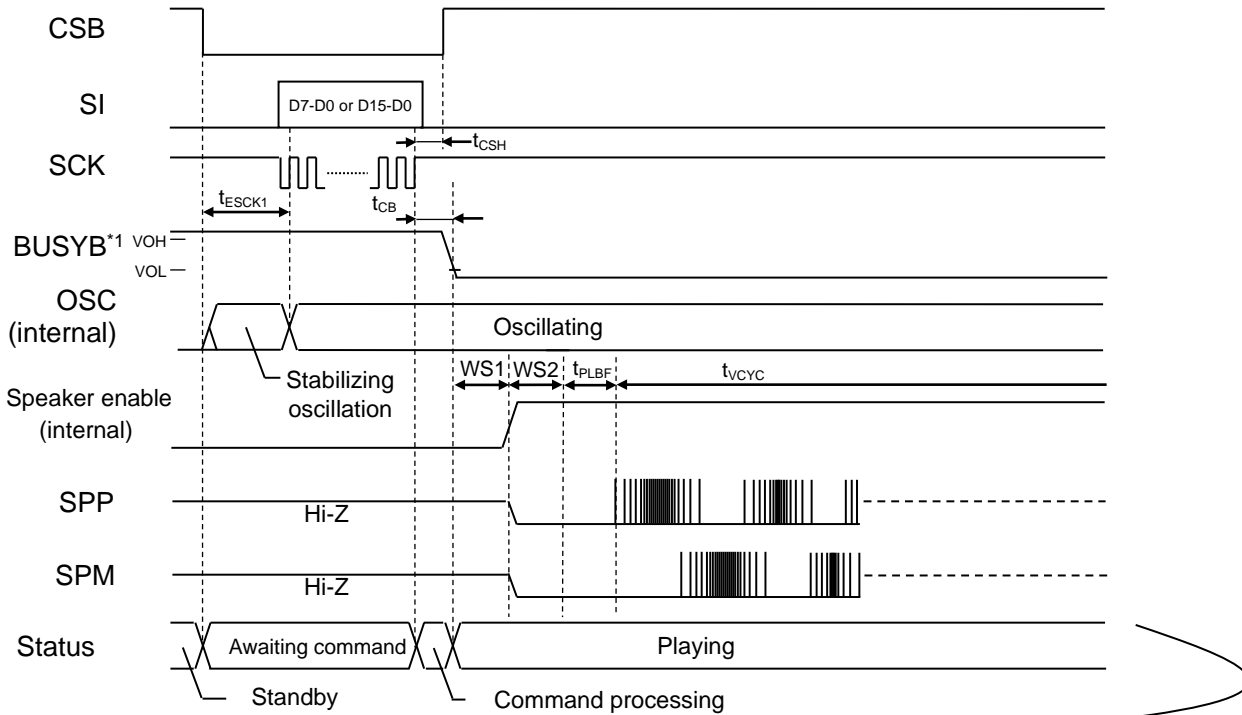

*1 : Used with default "H" Level, CMOS output

• Scheduled Play Once mode and Scheduled Play mode Timing (Continuous Play)

In response to playback request for the next phrase (n), the phrase (m) is played back to the end, and then playback of the phrase (n) starts.

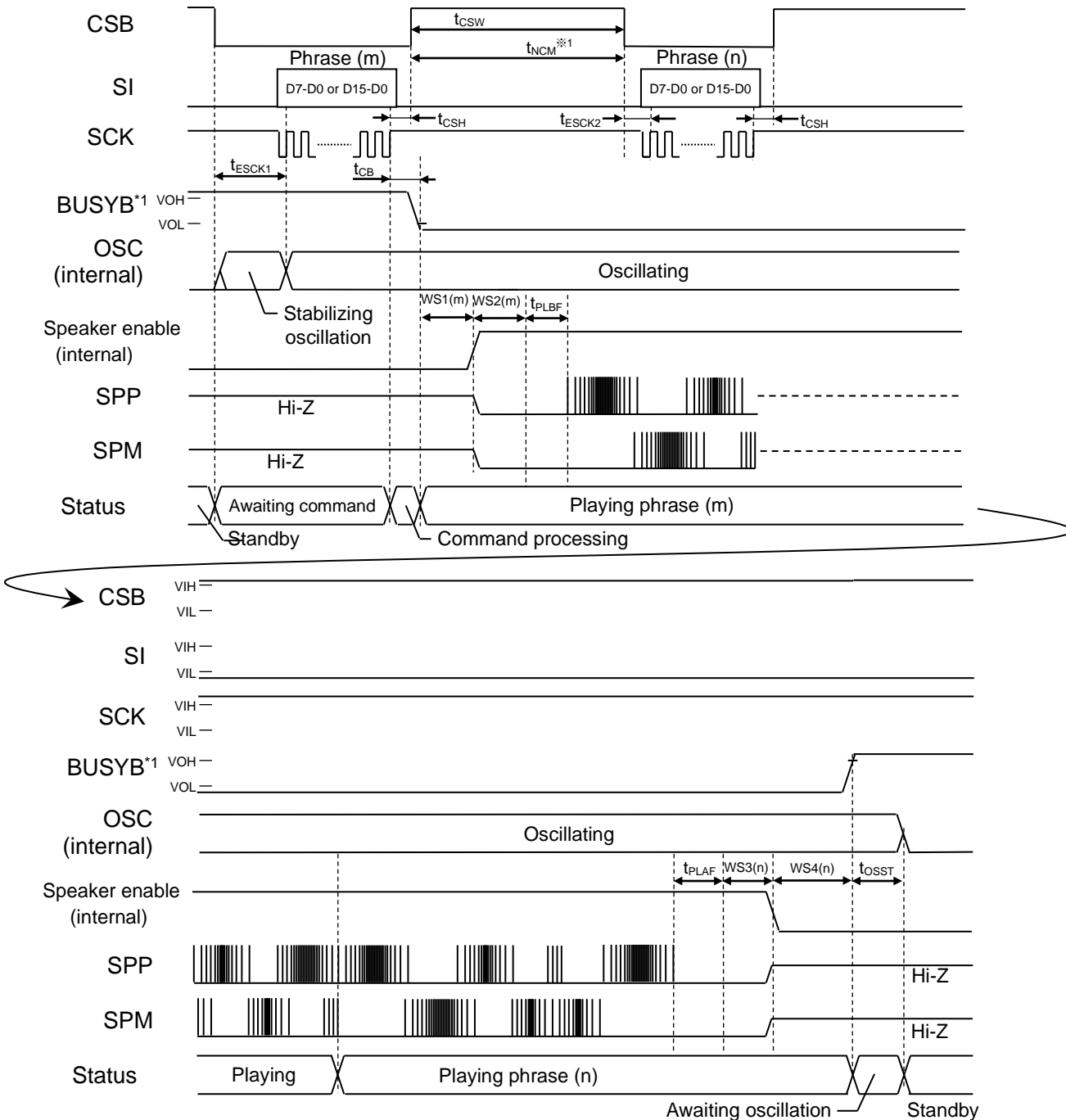

*1: Used with default "H" Level, CMOS output

*Under Scheduled Play mode, playback is stopped by STOP command.

Note 1: In Scheduled Play Once mode, the phrase (n) is played back immediately after the end of the playback of the phrase (m), in response to an input of a playback request (PHRASE command) for the next phrase (phrase (n)) within t_{NCM} .

- Change Immediately Once mode and Change Immediately mode Timing (Continuous Play)

After inputting the next PHRASEn command(Phrase(n)), fade-out of the playback(Phrase(m)) is carried out and thePhrase(n) playback is started.

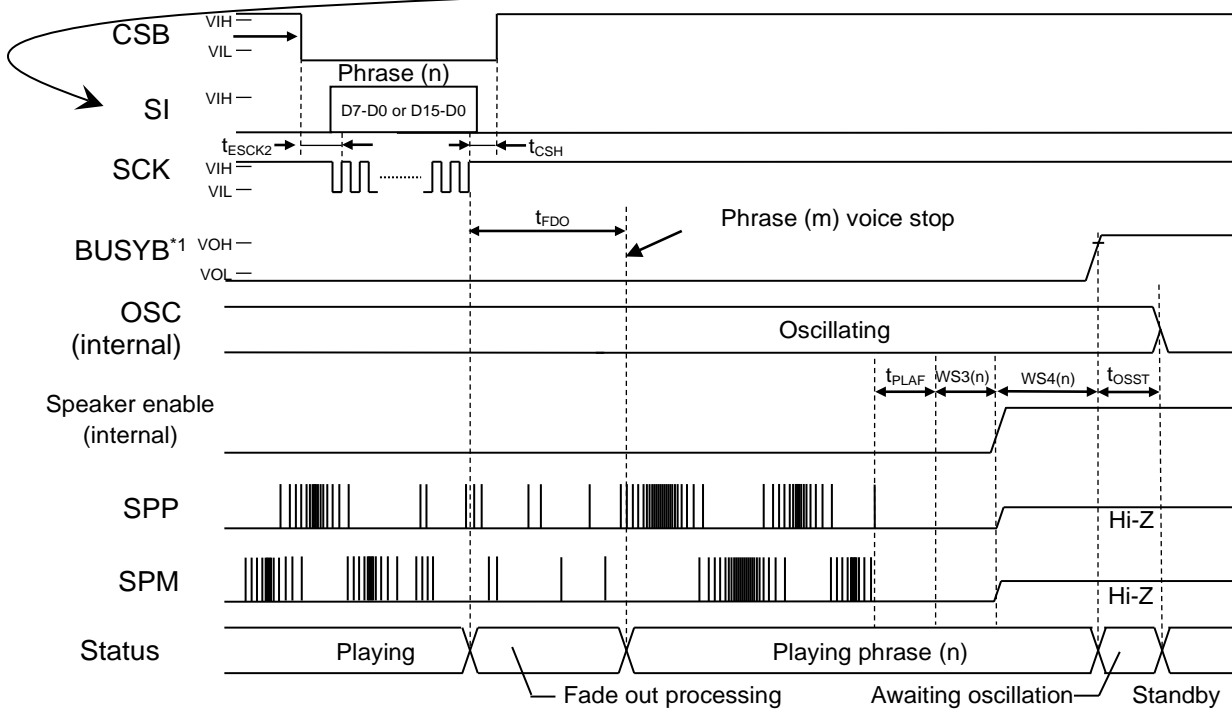
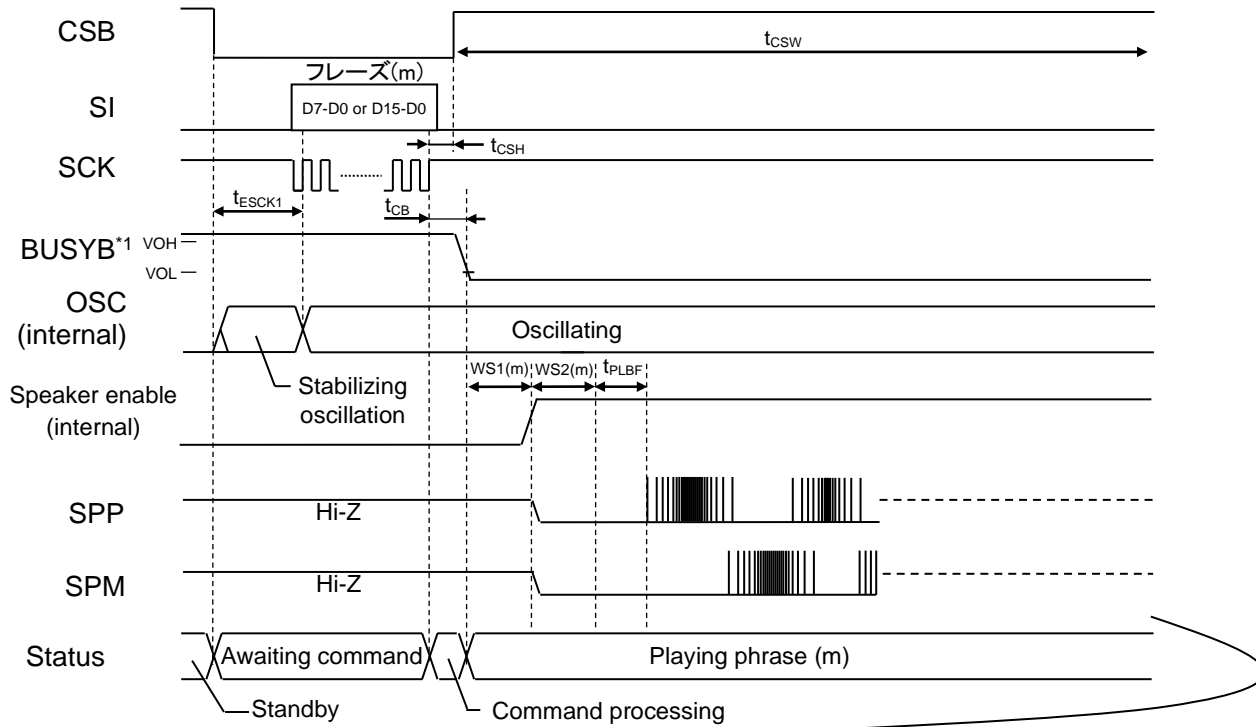

*1: Used with default "H" Level, CMOS output

- Under Change Immediately mode, playback is stopped by STOP command.

• Scheduled Play Once mode and Scheduled Play mode Timing sound stop timing

After STOP command is input, the phrase is played back until the end, and the playback stops.

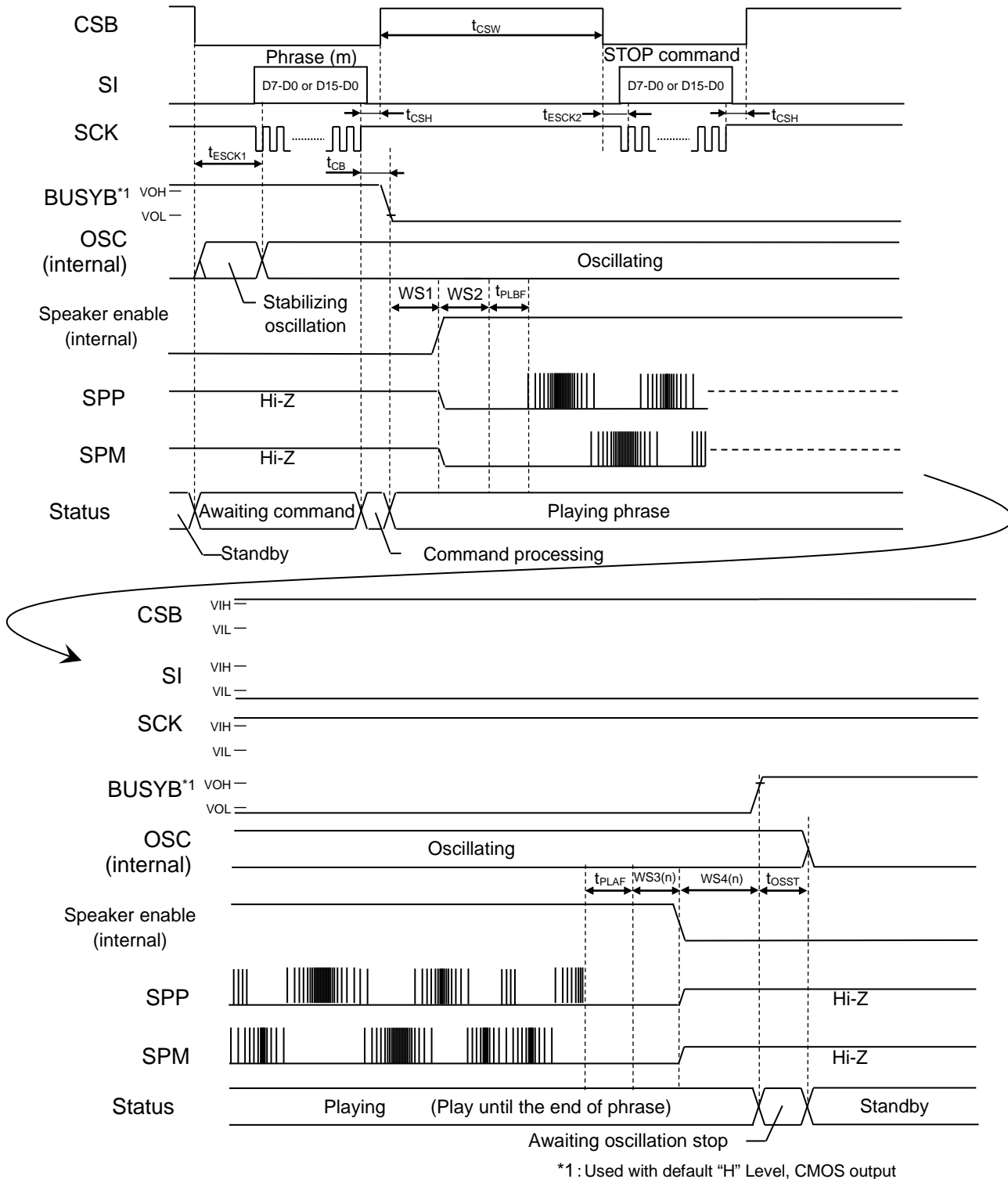

- Change Immediately Once mode and Change Immediately mode sound stop timing

After STOP command is input, the sound fades out, and the playback stops.

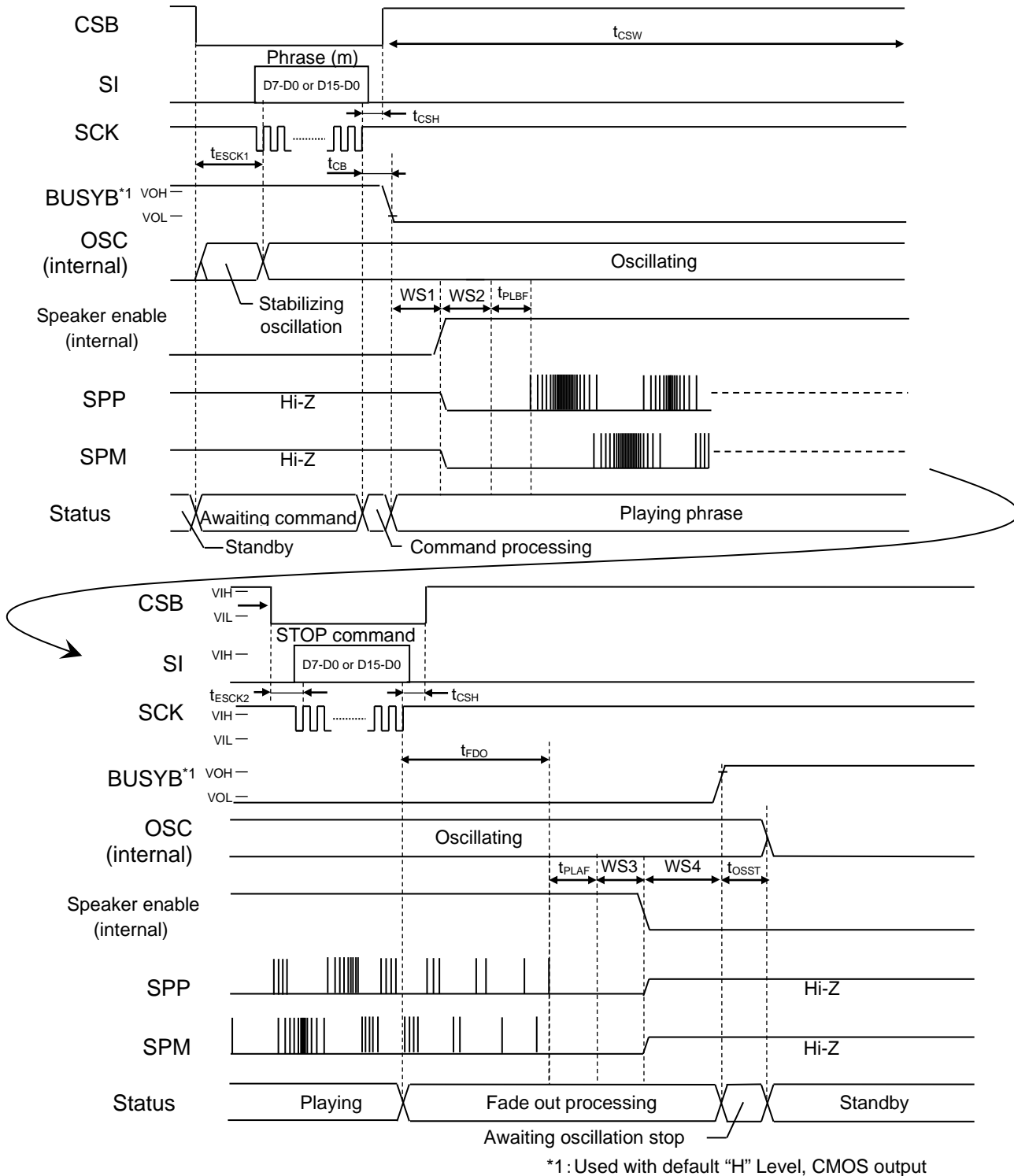

• Disconnection detection timing

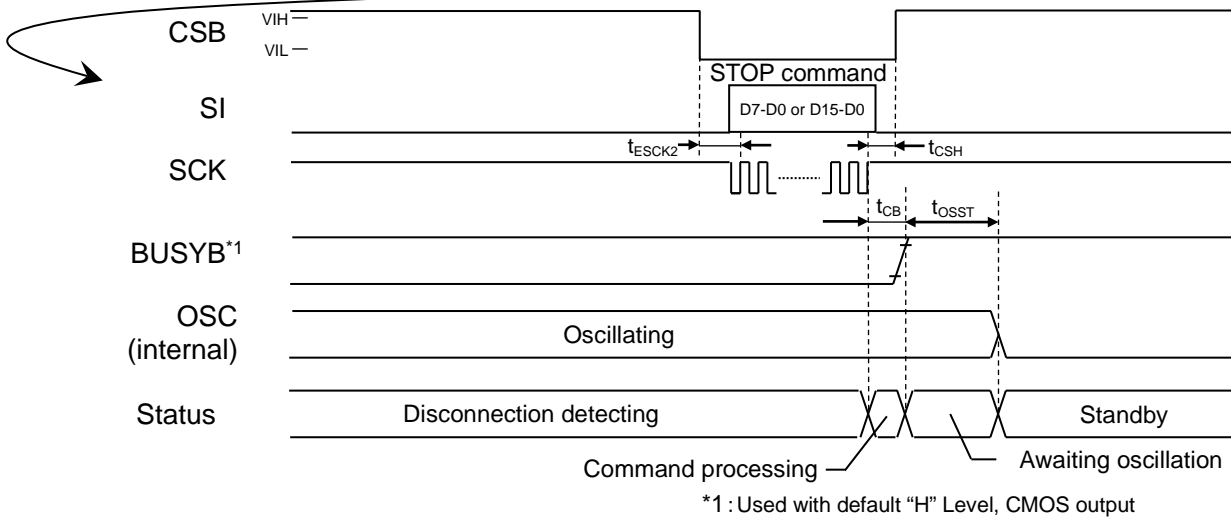
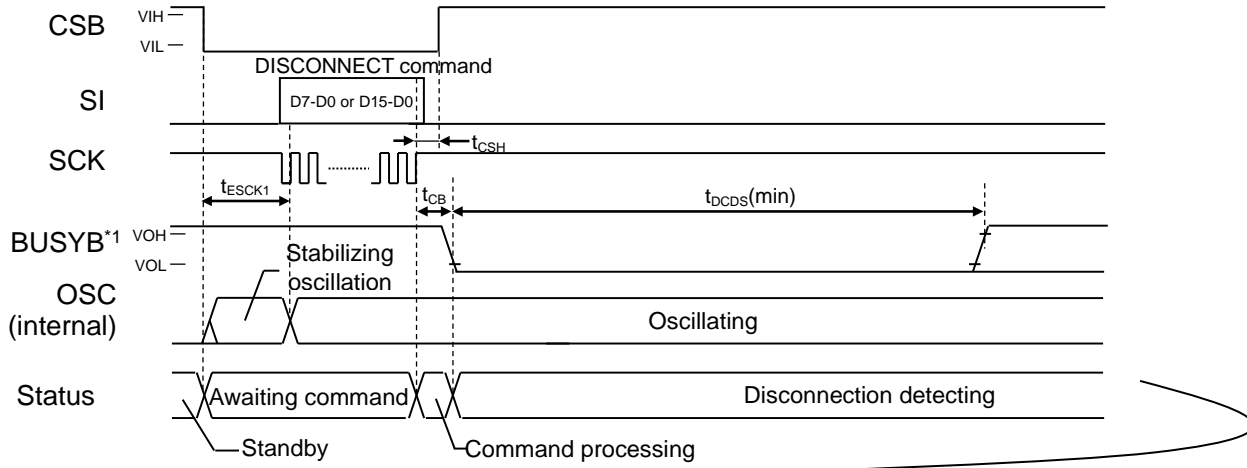

*1: Used with default "H" Level, CMOS output

• Speaker short detection timing

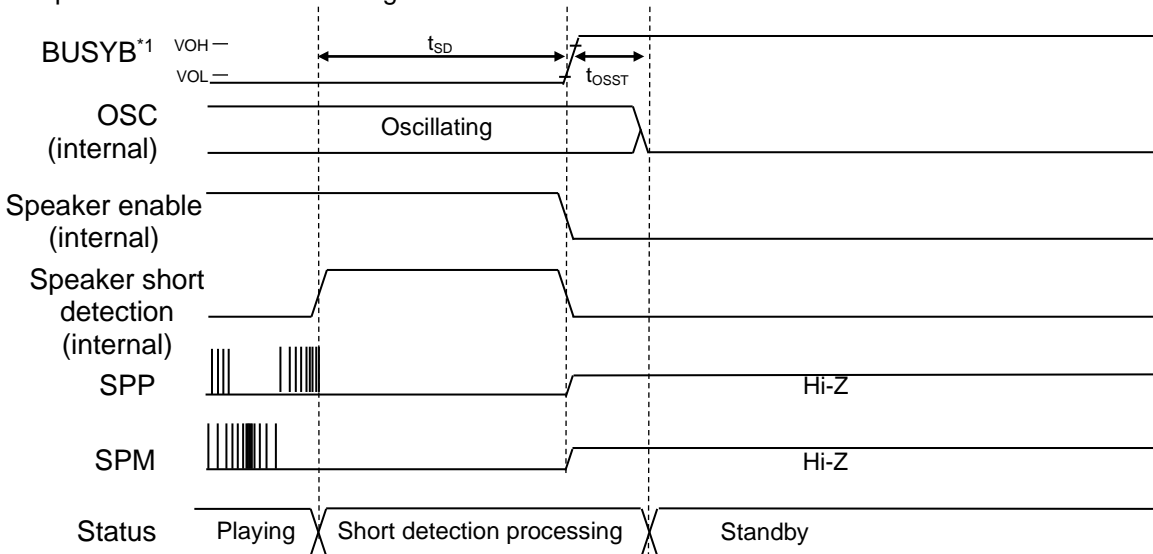

*1: Used with default "H" Level, CMOS output

- Flash memory access mode
- ◆ Flash memory access mode entry

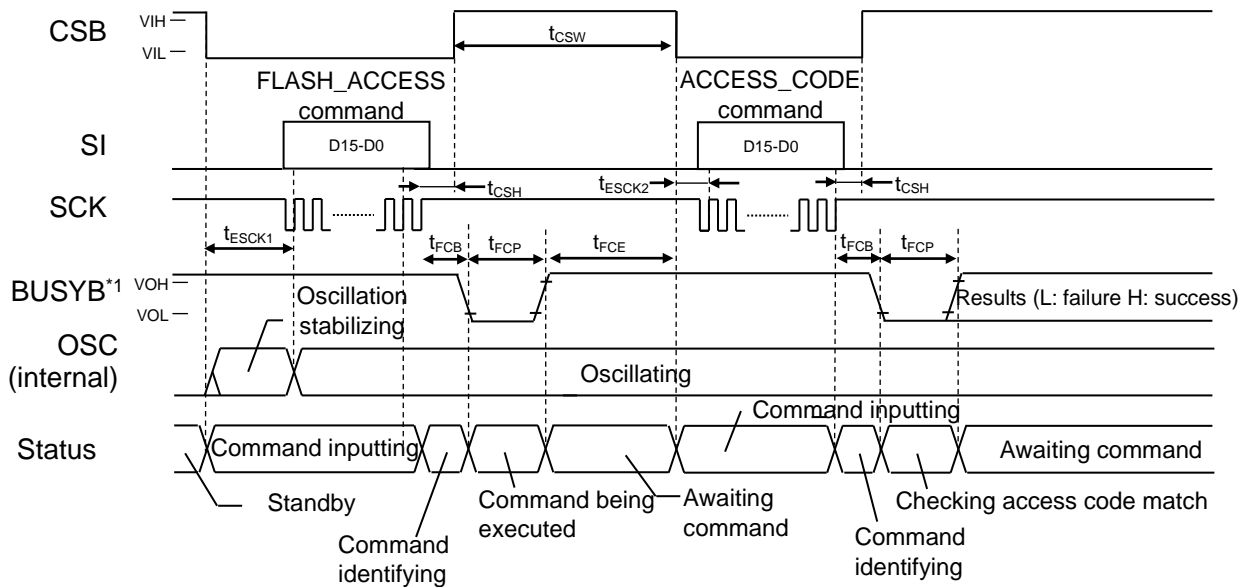

*1: When used with default "H" level, CMOS output

- ◆ Flash memory erase or version check

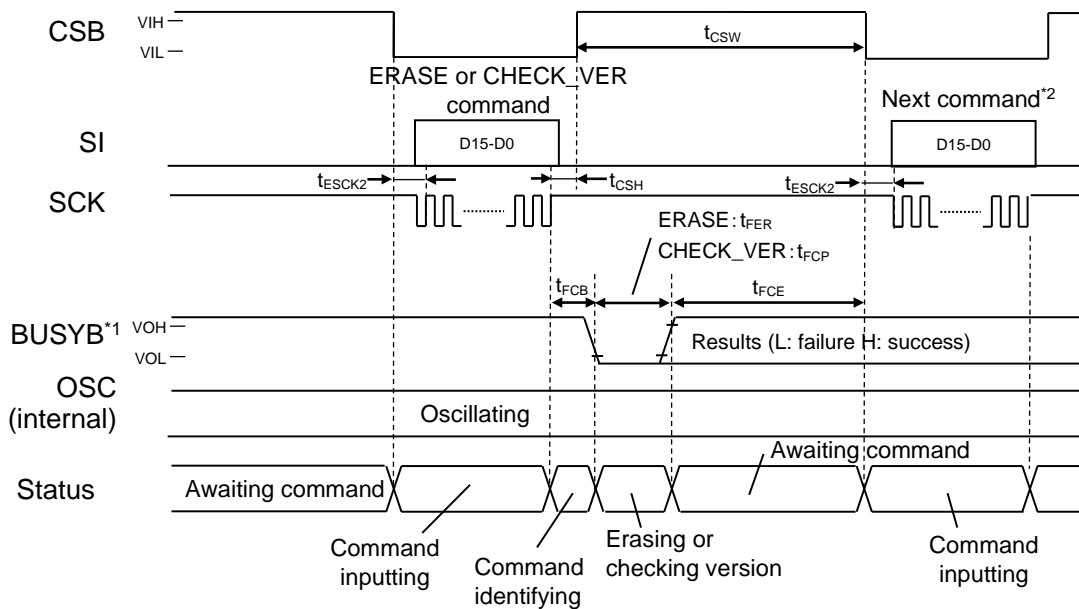

*1: When used with default "H" level, CMOS output

*2: To end only by version check, enter reset.

◆ “Write and verify” or “Verify”

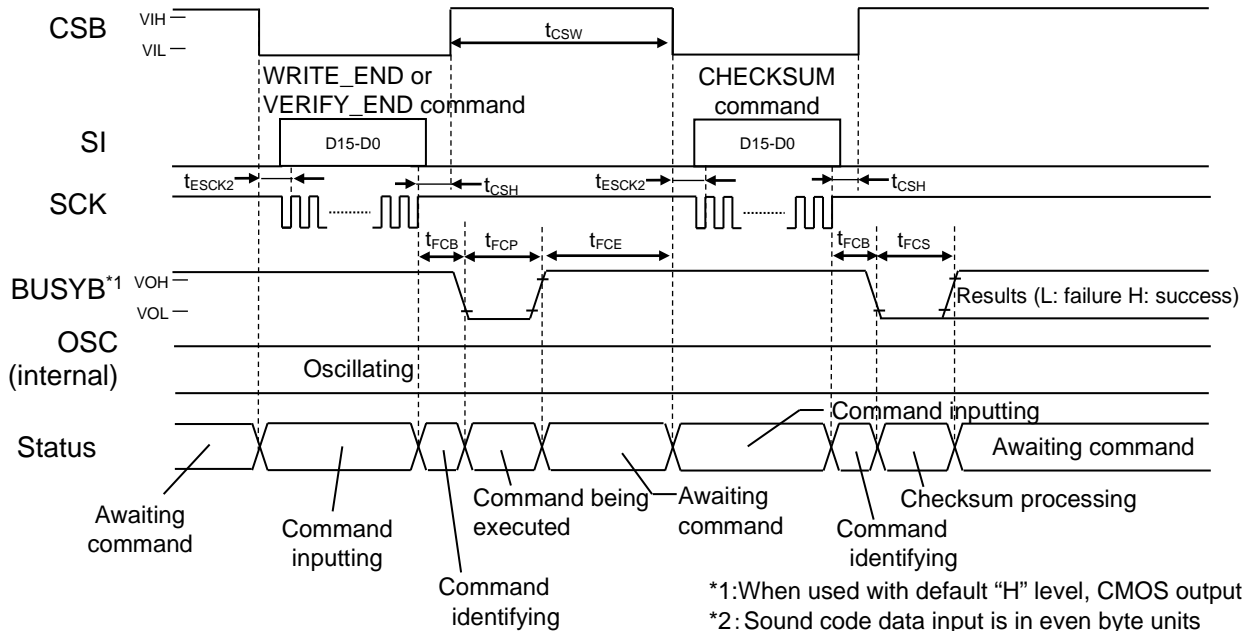
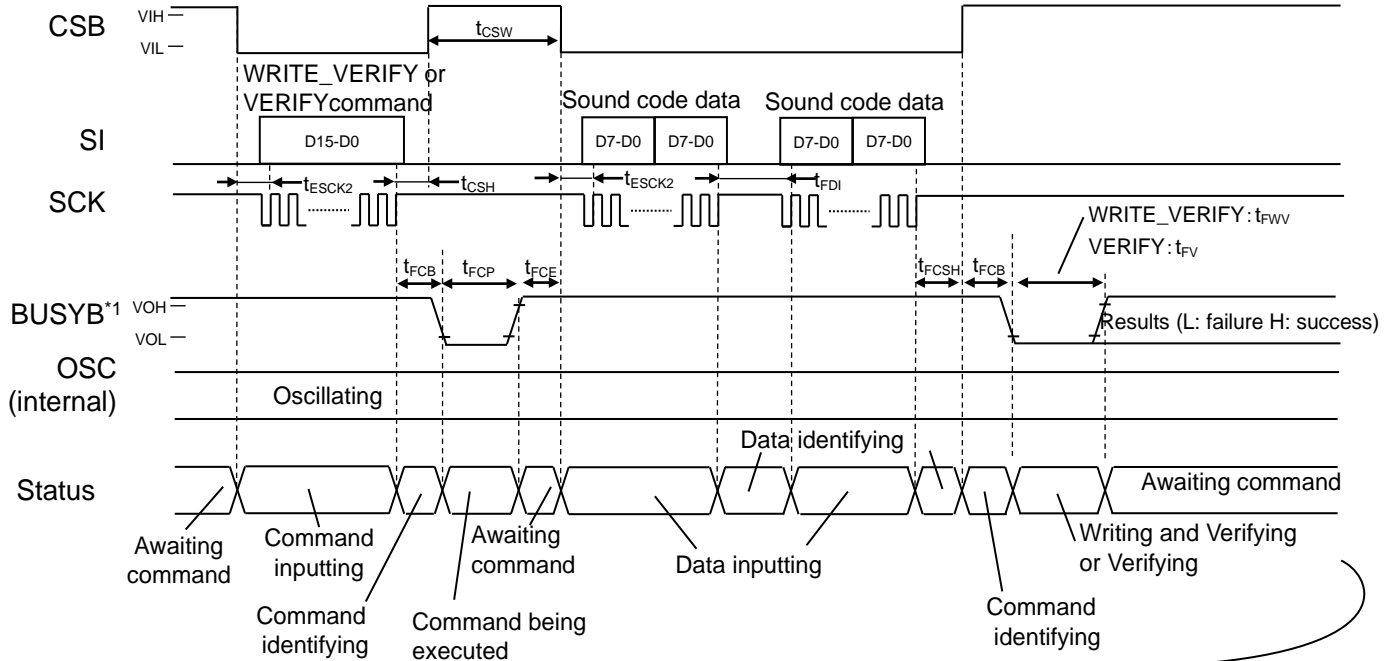

*1: When used with default “H” level, CMOS output
 *2: Sound code data input is in even byte units

■ Code Option Setting Item

Items set on Code Option Setting screen for Speech LSI Utility are as follows.

For the blank product(-NNNTD), the setting described as (Blank) or description about blank product in an each item is set. Because Code Option Setting item contains MCU interface specification items, if the Code Option Setting Items are changed, be sure to manage the settings before and after the change as MCU interface inconsistency does not occur.

•Speaker pin short detection function

Use of speaker pin short detection function	<input type="checkbox"/> (Not used)
	<input type="checkbox"/> (Used) (Blank)

•Num of Phrases and Command type setting

Num of Phrases / Command type	<input type="radio"/> 30 phrases / 1 byte (30 phrases can be played and communicate with 1-byte command)
	<input type="radio"/> 62 phrases / 2 byte (62 phrases can be played and communicate with 1-byte command) (Blank)

Select 62 phrases / 2 byte when using the flash memory access function by MCU.

STOP/DISCONNECT Command	Command bit sequence	
<input type="radio"/> Standard	STOP command	Set 00h
	DISCONNECT command	Set 01h
<input type="radio"/> Custom	STOP command	Set any bit sequence (Blank) ^{*1}
	DISCONNECT command	Set any bit sequence (Set value different from STOP command) (Blank) ^{*2}

^{*1} : 3Fh is set in the blank product.

^{*2} : 00h is set in the blank product.

•BUSYB Pin Setting

Use of BUSYB	Initial State	Condition	BUSYB pin status
<input type="checkbox"/> (Not used)	<input type="radio"/> L level Output	^{*3}	Fixed to "L" output
	<input type="radio"/> H level Output	^{*3}	Fixed to "H" output
<input type="checkbox"/> (Used)	<input type="radio"/> L level Output	<input type="radio"/> CMOS	Output initial value "L" with CMOS output
		<input type="radio"/> Nch Open Drain	Output initial value "L" with Nch open drain output
		<input type="radio"/> Pch Open Drain	Output initial value HiZ with Pch open drain output
		<input type="radio"/> Hi-Z	Hiz output
	<input type="radio"/> H level Output	<input type="radio"/> CMOS	Output initial value "H" with CMOS output (Blank)
		<input type="radio"/> Nch Open Drain	Output initial value HiZ with Nch open drain output
		<input type="radio"/> Pch Open Drain	Output initial value "H" with Pch open drain output
		<input type="radio"/> Hi-Z	Hiz output

^{*3}: Setting value invalid

Check Use of BUSYB when using the flash memory access function by MCU.

• Clock synchronization Serial interface setting (SPI setting)

Data transfer type	<input type="radio"/> LSB first	Input serial data from LSB
	<input type="radio"/> MSB first	Input serial data from MSB (Blank)

Clock polarity	<input type="radio"/> Normal (H Level)	Use with initial value of SCK pin set to "H" level
	<input type="radio"/> Normal (L Level)	Use with initial value of SCK pin set to "L" level (Blank)

• Sound code data version information (Speech ROM Information)

Speech ROM Information	Set sound code data version information of any 8 bits string. FFh is set in the blank product.
------------------------	--

• Flash protect option

Flash protect option	<input type="radio"/> Not Use	Set FFh. Any access code can be unlocked when ACCESS_CODE command is entered. (Blank)
	<input type="radio"/> Use Lock protect	Set 69h. The flash memory access function is disabled. Select this if you do not use the flash memory access function. ^{*1}
	<input type="radio"/> Use Access code	Access codes of any 8 bits string other than FFh and 69h can be set. The flash memory access mode can be entered when the access codes match.

Select Use Lock protect when 30 phrases / 1 byte is selected by Command setting.

^{*1}: FLASH_ACCESS command is invalid. Even with this setting, the flash memory can be rewritten using SDCB Controller.

■ Phrase information Setting Item

The items to be set on the phrase info setting screen of Speech LSI Utility are as follows.

- Playback mode (EVENT Mode)
Set playback mode suitable for target playback, with reference to “Playback mode” in FUNCTIONAL DESCRIPTION.
- Volume setup
Set playback mode suitable for target playback, with reference to “Volume setup function” in FUNCTIONAL DESCRIPTION.
- Setting Wait time before and after volume playback (WS1,WS2,WS3,WS4)
Set desired Wait time with reference to “Function of setting wait time before and after playback (WS1, WS2, WS3, WS4)”.

■ TERMINATION OF THE V_{DDL} PIN

The V_{DDL} pin is the regulator output that is power supply pin for the internal logic circuits. Connect a capacitor between this pin and the ground in order to prevent noise generation and power fluctuation.

The recommended capacitance value is shown below. However, it is important to evaluate and decide using the own board.

Also, start the next operation after each output voltage is stabilized.

Pin	Recommended capacitance value	Remarks
V_{DDL}	$1\ \mu\text{F} \pm 30\%$	The larger the connection capacitance, the longer the settling time.

■ POWER SUPPLY WIRING

The power supplies of this LSI are divided into the following two:

- Power supply for logic circuitry (: DV_{DD})
- Power supply for speaker amplifier (: SPV_{DD})

The example of power connection is shown below

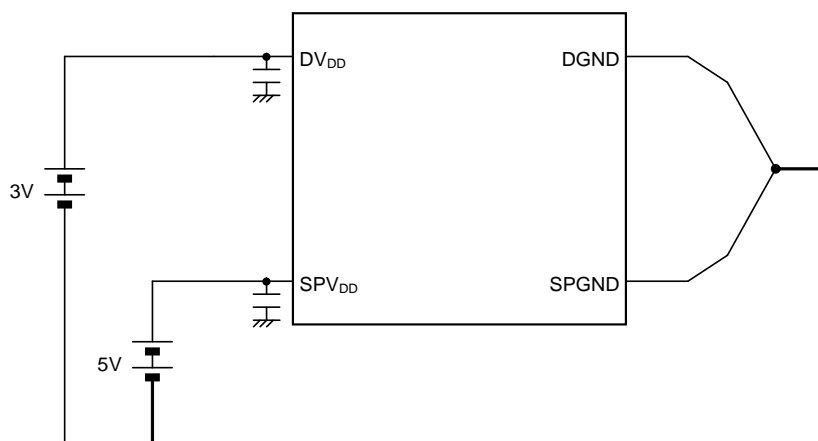
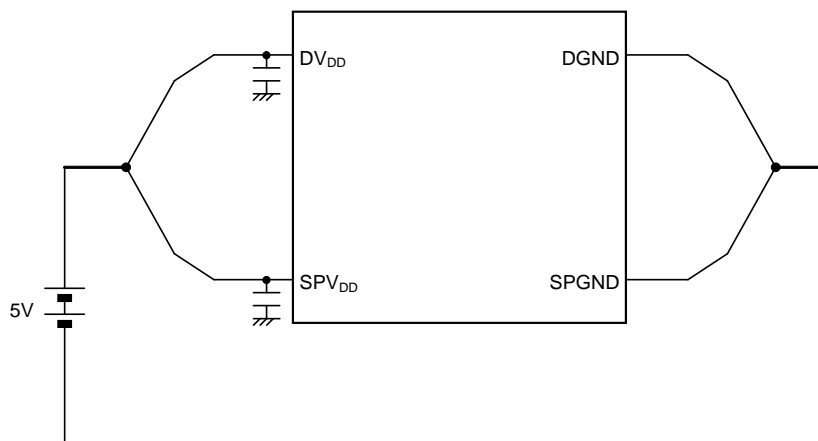

■ APPLICATION CIRCUIT

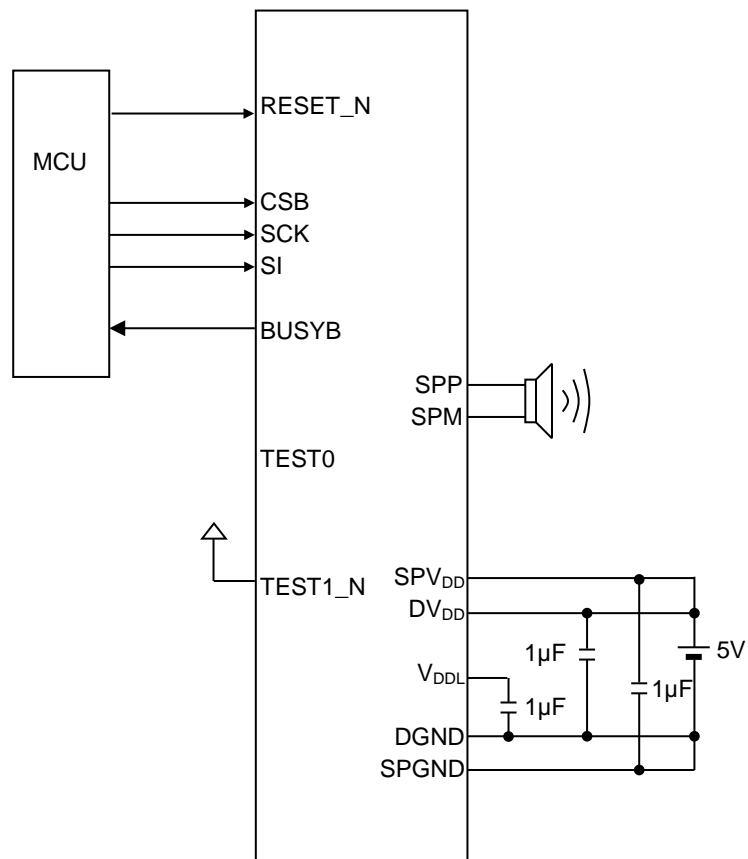

■ PACKAGE DIMENSIONS

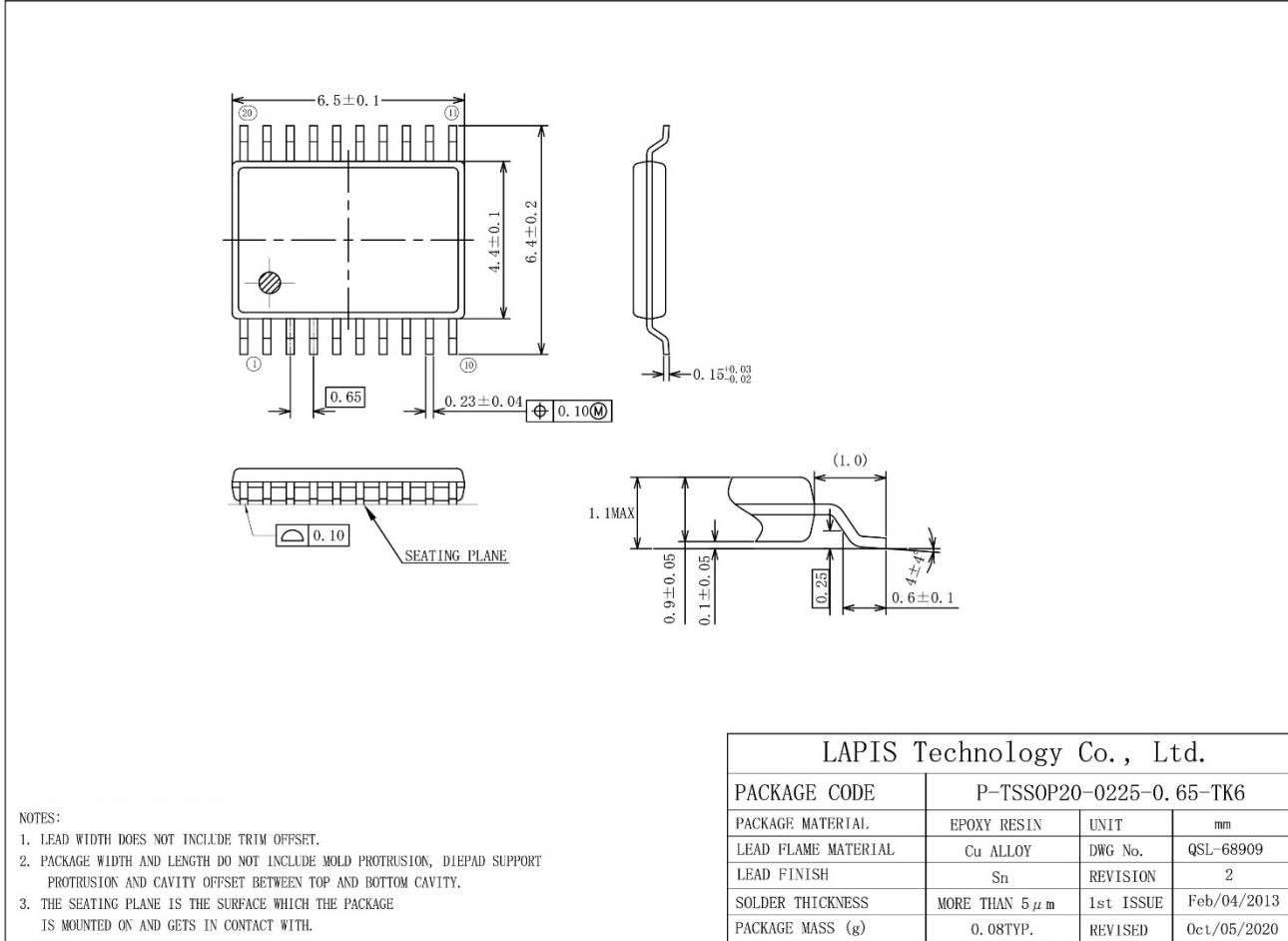

NOTES:

1. LEAD WIDTH DOES NOT INCLUDE TRIM OFFSET.
2. PACKAGE WIDTH AND LENGTH DO NOT INCLUDE MOLD PROTRUSION, DIEPAD SUPPORT PROTRUSION AND CAVITY OFFSET BETWEEN TOP AND BOTTOM CAVITY.
3. THE SEATING PLANE IS THE SURFACE WHICH THE PACKAGE IS MOUNTED ON AND GETS IN CONTACT WITH.

Notes for Mounting the Surface Mount Type Package

The surface mount type packages are very susceptible to heat in reflow mounting and humidity absorbed in storage. Therefore, before you perform reflow mounting, contact a ROHM sales office for the product name, package name, pin number, package code and desired mounting conditions (reflow method, temperature and times).

PCB Layer	JEDEC 4layers	JEDEC 2layers
PCB	(W/L/t= 76.2 / 114.3 / 1.6 (mm))	
Air cooling condition	Calm(0m/sec)	
Heat resistance(θ ja)	68.48[°C/W]	74.00[°C/W]
Heat resistance(θ jc)	0.61[°C/W]	0.61[°C/W]
Maximum power consumption of LSI (PMax) during 8Ω/1W speaker amp. output	0.3[W]	

TjMax of this LSI is 110 °C. TjMax is expressed with the following formulas.

$$TjMax = TaMax + \theta Ja \times PMax$$

■ REVISION HISTORY

Document No	Date	Page		Description
		Previous Edition	Current Edition	
FEDL22Q234-01	Jun. 15, 2021	-	-	Formal 1st edition.
FEDL22Q234-02	Jun. 20, 2022	8	8	Removed start time SPV _{DD} after starting DV _{DD} (t _{VDD})
		18, 25	18, 25	Added the note when using the playback commands
		18, 19	18, 19	Changed the command setting value in the main text from binary to hexadecimal
		40	40	Revised the command bit string description of the STOP / DISCONNECT command
		40, 41	40, 41	Added Code Optim Setting and its explanation of the blank product (-NNNTD)
		45	45	Described heat resistance and TjMax of this LSI
-	47	Added "Notes for product usage"		

Notes for product usage

1. HANDLING OF UNUSED INPUT PINS

Fix the unused input pins to the power pin or GND to prevent to cause the device performing wrong operation or increasing the current consumption due to noise, etc. If the handlings for the unused pins are described in the chapters, follow the instruction.

2. STATE AT POWER ON

At the power on, the internal setting and output of the ports are undefined until the power supply voltage reaches to the recommended operating condition and "L" level is input to the reset pin.

Be careful to design the application system does not work incorrectly due to the undefined data of internal setting and output of the ports.

3. CHARACTERISTICS DIFFERENCE BETWEEN THE PRODUCTS

Electrical characteristics, noise tolerance, noise radiation amount, and the other characteristics are different from each product.

When replacing from other product to LAPIS Technology products, please evaluate enough the apparatus/system which implemented LAPIS Technology products.

4. USE ENVIRONMENT

When using LAPIS Technology products in a high humidity environment and an environment where dew condensation, take moisture-proof measures.

Notes

- 1) The information contained herein is subject to change without notice.
- 2) When using LAPIS Technology Products, refer to the latest product information (data sheets, user's manuals, application notes, etc.), and ensure that usage conditions (absolute maximum ratings, recommended operating conditions, etc.) are within the ranges specified. LAPIS Technology disclaims any and all liability for any malfunctions, failure or accident arising out of or in connection with the use of LAPIS Technology Products outside of such usage conditions specified ranges, or without observing precautions. Even if it is used within such usage conditions specified ranges, semiconductors can break down and malfunction due to various factors. Therefore, in order to prevent personal injury, fire or the other damage from break down or malfunction of LAPIS Technology Products, please take safety at your own risk measures such as complying with the derating characteristics, implementing redundant and fire prevention designs, and utilizing backups and fail-safe procedures. You are responsible for evaluating the safety of the final products or systems manufactured by you.
- 3) Descriptions of circuits, software and other related information in this document are provided only to illustrate the standard operation of semiconductor products and application examples. You are fully responsible for the incorporation or any other use of the circuits, software, and information in the design of your product or system. And the peripheral conditions must be taken into account when designing circuits for mass production. LAPIS Technology disclaims any and all liability for any losses and damages incurred by you or third parties arising from the use of these circuits, software, and other related information.
- 4) No license, expressly or implied, is granted hereby under any intellectual property rights or other rights of LAPIS Technology or any third party with respect to LAPIS Technology Products or the information contained in this document (including but not limited to, the Product data, drawings, charts, programs, algorithms, and application examples, etc.). Therefore LAPIS Technology shall have no responsibility whatsoever for any dispute, concerning such rights owned by third parties, arising out of the use of such technical information.
- 5) The Products are intended for use in general electronic equipment (AV/OA devices, communication, consumer systems, gaming/entertainment sets, etc.) as well as the applications indicated in this document. For use of our Products in applications requiring a high degree of reliability (as exemplified below), please be sure to contact a LAPIS Technology representative and must obtain written agreement: transportation equipment (cars, ships, trains, etc.), primary communication equipment, traffic lights, fire/crime prevention, safety equipment, medical systems, servers, solar cells, and power transmission systems, etc. LAPIS Technology disclaims any and all liability for any losses and damages incurred by you or third parties arising by using the Product for purposes not intended by us. Do not use our Products in applications requiring extremely high reliability, such as aerospace equipment, nuclear power control systems, and submarine repeaters, etc.
- 6) The Products specified in this document are not designed to be radiation tolerant.
- 7) LAPIS Technology has used reasonable care to ensure the accuracy of the information contained in this document. However, LAPIS Technology does not warrant that such information is error-free and LAPIS Technology shall have no responsibility for any damages arising from any inaccuracy or misprint of such information.
- 8) Please use the Products in accordance with any applicable environmental laws and regulations, such as the RoHS Directive. LAPIS Technology shall have no responsibility for any damages or losses resulting non-compliance with any applicable laws or regulations.
- 9) When providing our Products and technologies contained in this document to other countries, you must abide by the procedures and provisions stipulated in all applicable export laws and regulations, including without limitation the US Export Administration Regulations and the Foreign Exchange and Foreign Trade Act..
- 10) Please contact a ROHM sales office if you have any questions regarding the information contained in this document or LAPIS Technology's Products.
- 11) This document, in part or in whole, may not be reprinted or reproduced without prior consent of LAPIS Technology.

(Note) "LAPIS Technology" as used in this document means LAPIS Technology Co., Ltd.

Copyright 2021-2022 LAPIS Technology Co., Ltd.

LAPIS Technology Co.,Ltd.

2-4-8 Shinyokohama, Kouhoku-ku, Yokohama 222-8575, Japan
<https://www.lapis-tech.com/en/>