

Dear customer

LAPIS Semiconductor Co., Ltd. ("LAPIS Semiconductor"), on the 1st day of October, 2020, implemented the incorporation-type company split (shinsetsu-bunkatsu) in which LAPIS established a new company, LAPIS Technology Co., Ltd. ("LAPIS Technology") and LAPIS Technology succeeded LAPIS Semiconductor's LSI business.

Therefore, all references to "LAPIS Semiconductor Co., Ltd.", "LAPIS Semiconductor" and/or "LAPIS" in this document shall be replaced with "LAPIS Technology Co., Ltd."

Furthermore, there are no changes to the documents relating to our products other than the company name, the company trademark, logo, etc.

Thank you for your understanding.

LAPIS Technology Co., Ltd.

October 1, 2020



ML2272X-XXX/ML2276X-XXX

Speech Synthesis LSI with Built-in P2ROM Including Speech-Speed Conversion/Pitch Conversion Functions

GENERAL DESCRIPTION

The ML2272X(ML22725/ML22724/ML22723-XXX) and ML2276X(ML22765/ML22764/ML22763-XXX) are speech synthesis LSIs with built-in P2ROM that stores speech data.

These LSIs include speech speed conversion, pitch conversion, edit ROMs, ADPCM2 decoders, 16-bit DA converters, low pass filters, and monaural speaker amplifiers. The ML2272X supports the synchronous serial interface and the ML2276X supports the I2C interface. By integrating all the functions required for speech output into a single chip, these LSIs can be more easily incorporated in compact portable devices.

- Built-in memory capacity and maximum vocal reproduction time:

the following table (in 4-bit ADPCM2 mode)

Product name	ROM capacity	Maximum vocal reproduction time (sec) *		
		F _S = 8.0 kHz	F _S = 16 kHz	F _S = 32 kHz
ML22725-XXX/ML22765	16 Mbits	522	261	130
ML22724-XXX/ML22764	8 Mbits	260	130	64
ML22723-XXX/ML22763	4 Mbits	129	64	32

(*: Speech -speed or pitch conversion functions is not used.)

- voice synthesis method: 4-bit ADPCM2
8-bit Nonlinear PCM
8-bit PCM, 16-bit PCM
Can be specified for each phrase.
- Sampling frequency(F_S): 4.0 / 5.3 / 6.4 / 8.0 / 10.6 / 12.0 / 12.8 / 16.0 / 21.3 / 24.0 / 25.6 / 32.0 / 48.0 kHz
F_S can be specified for each phrase.
- Built-in low-pass filter and 16-bit DA converter
- Speaker driving amplifier: 0.7 W (8Ω, DV_{DD}=5 V, Ta=25°C)
Analog input: 2ch (internal: 1ch, external: 1ch)
- CPU command interface: 3-wired serial clock-synchronized (ML2272X)
I2C interface (ML2276X)
- Maximum number of phrases: 4096 phrases, from 000h to 3FFh (1024 phrases/bank)
- Memory bank switching: Enabled between bank 1 and bank 4 using the SEL0 and SEL1 pins.
- Volume control: 32 levels (OFF is included) can be set by CVOL command.
50 levels (OFF is included) can be set by AVOL command.
- Repeat function: LOOP commands
- Speech speed conversion function ×0.50 to ×2.00 (150 levels: 0.01 step)
- Pitch conversion function ±20% (40 levels: 1% step width)
- Source oscillation frequency: 4.096 MHz
- Power supply voltage: 2.7 to 3.6V / 4.5 to 5.5 V
- Operating temperature range: -40°C to +85°C
- Package: 30-pins plastic SSOP (P-SSOP30-56-0.65-ZK6-MC)
- Product name: ML22725-xxxMB, ML22724-xxxMB, ML22723-xxxMB
ML22765-xxxMB, ML22764-xxxMB, ML22763-xxxMB
(xxx: ROM code No.)

The table below summarizes the differences from the ML2216 and ML22800 series.

Parameter	ML2216	ML22800 series	ML22725/ML22724/ ML22723-XXX	ML22765/ML22764/ ML22763-XXX
CPU interface	Serial	←	←	I2C
Playback method	4-bit ADPCM2 8-bit straight PCM 8-bit nonlinear PCM 16-bit straight PCM	←	←	←
Maximum number of phrases	256	1024 (256/bank)	4096 (1024/bank)	←
Sampling frequency (kHz)	4.0/5.3/6.4/ 8.0/10.6/12.8 16.0	←	4.0/5.3/6.4/8.0/ 10.6/12.0/12.8/ 16.0/21.3/24.0/ 25.6/32.0/48.0	←
Clock frequency	4.096MHz (with a built-in crystal oscillator circuit)	←	←	←
D/A converter	12 bits	12 bits	16 bits	←
Low-pass filter	3rd order comb filter	3rd order comb filter	FIR interpolation filter	←
Speaker driving amplifier	Built-in 0.3W (8Ω, DV _{DD} = 5 V)	No	Built-in 0.7W (8Ω, DV _{DD} = 5 V)	←
Speech speed/pitch conversion	No	←	Yes	←
Edit ROM function	Yes	←	←	←
Volume control	16 levels	←	32 levels	←
Silence insertion	Yes 20 ms to 1024 ms (4 ms/step)	←	←	←
Repeat function	Yes	←	←	←
Interval at which a seam is silent during continuous playback (Note)	No	←	←	←
Power supply voltage	2.7 V to 5.5 V	2.7 V to 3.6 V	2.7 V to 5.5 V	←
Package	44-pin QFP	30-pin SSOP	←	←

*1: Continuous playback as shown below is possible.
(Playback method: 8-bit straight PCM, 8-bit non-linear PCM, 16-bit straight PCM)

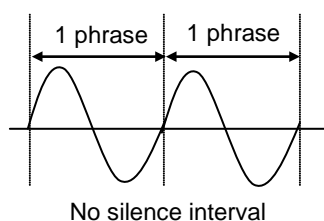

BLOCK DIAGRAMS

(ML22725/ML22724/ML22723-XXX)

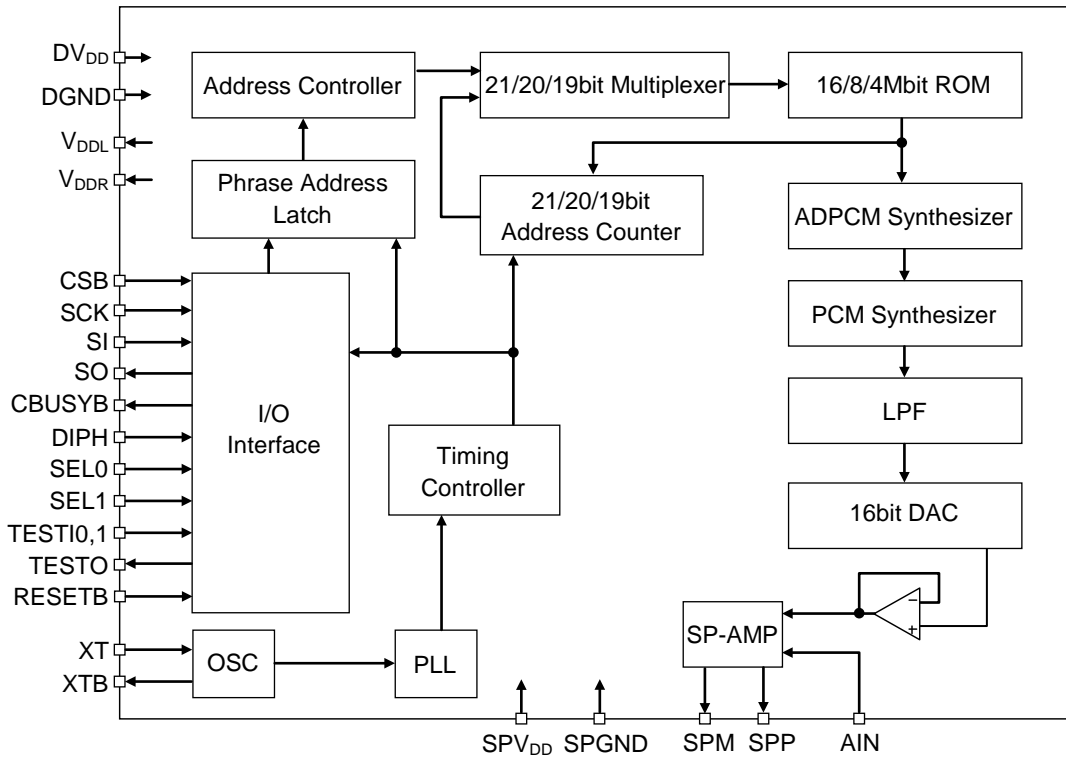

(ML22765/ML22764/ML22763-XXX)

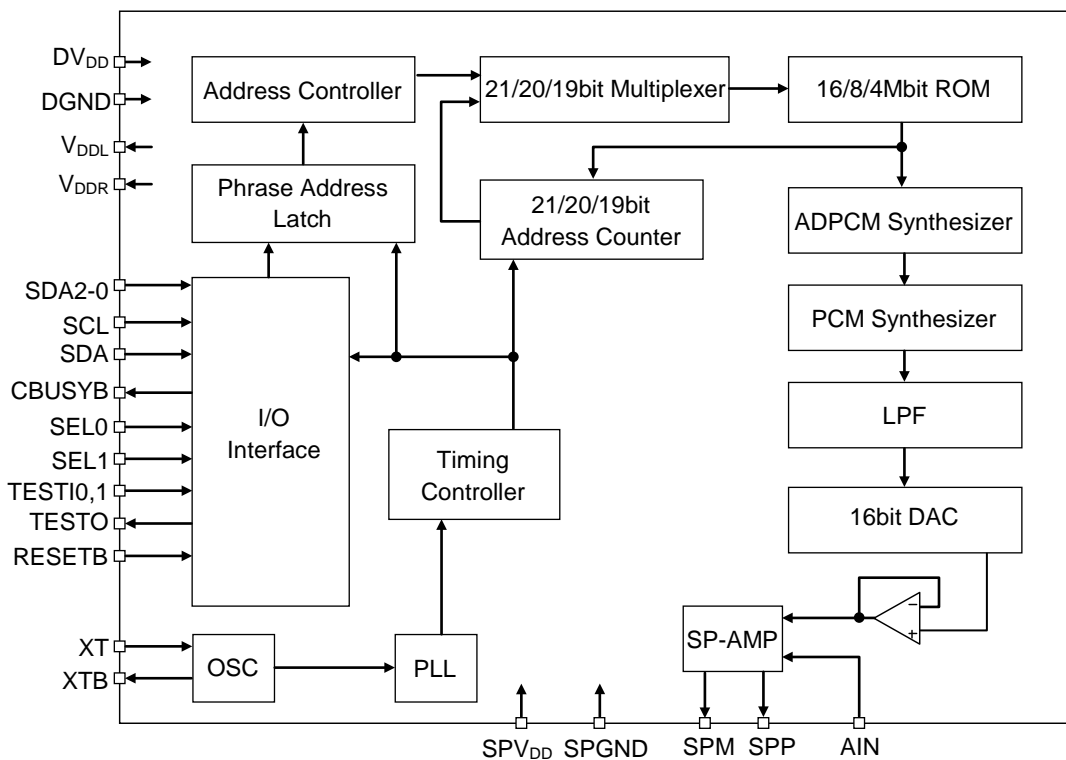

PIN CONFIGURATIONS (TOP VIEW)

ML22725/ML22724/ML22723-XXXMB (Synchronous serial interface)

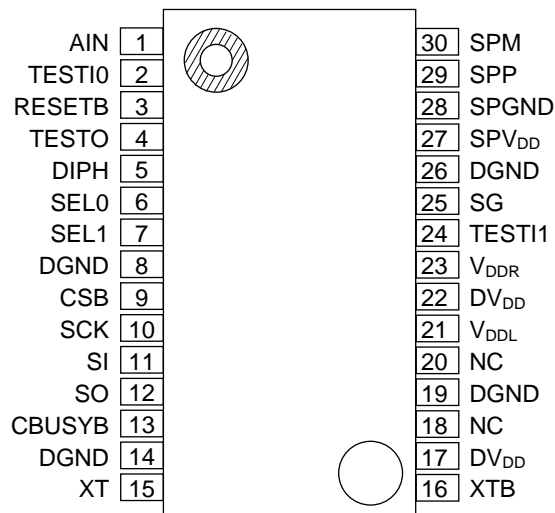

NC: No Connection

30-Pin Plastic SSOP

ML22765/ML22764/ML22763-XXXMB (I2C interface)

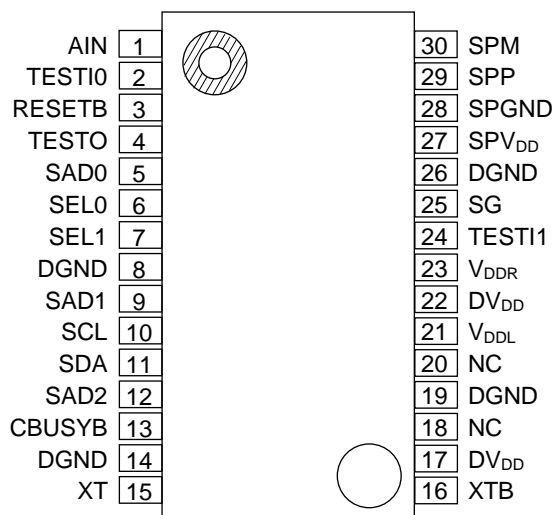

NC: No Connection

30-Pin Plastic SSOP

PIN DESCRIPTION (COMMON TO ALL PRODUCTS)

Pin	Symbol	I/O	Initial value (*1)	Description
1	AIN	I	0	Input pin for speaker amplifier.
2	TESTI0	I	0	Input pin for testing. Fix this pin to "L" level (DGND level). This pin has a pull-down resistor built in.
3	RESETB	I	0 (*2)	Input pin for reset.. At the "L" level, the LSI enters initial state. During reset, the entire circuitry stops and enters power down state. Input "L" level when power is supplied. After the power supply voltage is stable, drive this pin to "H" level. Then the entire circuitry can be powered up. This pin has a pull-up resistor built in.
4	TESTO	O	Hi-Z	Output pin for testing. Leave this pin open.
6, 7	SEL0 SEL1	I	0	Memory bank switching pins. Fix these pins to "L" level when the memory bank function is not used.
8, 14, 19, 26	DGND	—	—	Digital ground pin. Also serves as a ground pin for the internal memory.
13	CBUSYB	O	1	Output pin for command processing status.. This pin outputs "L" level during command processing. Any command should be entered when this pin is "H" level.
15	XT	I	0	Connect to the crystal or ceramic resonator. A feedback resistor around 1 M Ω is built in between this pin and the XTB pin. Use this pin if need to use an external clock. If the resonator is used, connect it as close to this pin as possible.
16	XTB	O	1	Connects to the crystal or ceramic resonator. When to use an external clock, leave this pin open. If the resonator is used, connect it as close to this pin as possible.
17, 22	DV _{DD}	—	—	Power supply pins for logic circuitry. Connect a capacitor of 0.1 μ F or more between these pins and DGND pins.
18, 20	N.C	—	—	No-connected pins. Leave these pins open.
21	V _{DDL}	—	0	Regulator output pin for internal logic circuitry. Connect a capacitor recommended between this pin and DGND pin.
23	V _{DDR}	—	0	Regulator output pin for Built-in ROM. Connect a capacitor recommended between this pin and DGND pin.
24	TESTI1	I	0	Input pin for testing. Fix this pin to "L" level (DGND level). This pin has a pull-down resistor built in.
25	SG	—	0	Reference voltage output pin for the speaker amplifier built-in. Connect a capacitor recommended between this pin and DGND pin.
27	SPV _{DD}	—	—	Power supply pin for the speaker amplifier. Connect a bypass capacitor of 0.1 μ F or more between this pin and SPGND pin.
28	SPGND	—	—	Ground pin for the speaker amplifier.
29	SPP	O	0	Positive(+) output pin of the speaker amplifier built-in. Serves as the LINE output (*3), if built-in speaker amplifier is not used.
30	SPM	O	Hi-Z	Negative(-) output pin of the speaker amplifier built-in.

*1: Indicates the initial value during reset input or power down.

*2: "H" during power down.

*3: Outputs a voice signal before amplified by the speaker amplifier built-in.

PIN DESCRIPTION (FOR ML2272X SYNCHRONOUS SERIAL INTERFACE)

Pin	Symbol	I/O	Initial value (*1)	Description
5	DIPH	I	0	Set pin of the SCK clock edge. When this pin is "L" level, rising edge is available for input(SI) and falling edge is available for output(SO). When this pin is "H" level, falling edge is available for input(SI) and rising edge is available for output(SO).
9	CSB	I	1	Chip select pin. At the "L" level, data input/output is available.
10	SCK	I	0	Synchronous clock input pin for serial interface.
11	SI	I	0	Input pin of synchronous serial data. When the DIPH pin is "L" level, data is shifted in at the rising edges of the SCK clock pulses. When the DIPH pin is "H" level, data is shifted in at the falling edges of the SCK clock pulses.
12	SO	O	Hi-Z	Output pin of synchronous serial data. When the DIPH pin is "L" level, data is output at the falling edges of the SCK clock pulses. When the DIPH pin is "H" level, data is output at the rising edges of the SCK clock pulses. When the CSB pin is "H" level, this pin is Hi-Z state.

*1: Indicates the initial value during reset input or power down.

PIN DESCRIPTION (FOR ML2276X I2C INTERFACE)

Pin	Symbol	I/O	Initial value (*1)	Description
5, 9, 12	SAD0 SAD1 SAD2	I	0	Set pin of the slave address.
10	SCL	I	0	Clock input pin for I2C serial interface. This pin should be connected to pull-up resistor.
11	SDA	IO	0	Input/output pin for I2C serial data. Use for setting the mode of write/read and writing address, writing data or reading data. This pin should be connected to pull-up resistor. (N-ch MOS) open drain, when output mode. High impedance(Hi-Z), when input mode.

*1: Indicates the initial value during reset or power down.

ABSOLUTE MAXIMUM RATINGS

(DGND = SPGND = 0 V, Ta = 25°C)

Parameter	Symbol	Condition	Rating	Unit
Power supply voltage	DV _{DD} , SPV _{DD}	—	-0.3 to +7.0	V
Input voltage	V _{IN}	—	-0.3 to DV _{DD} +0.3	V
Power dissipation	P _D		938	mW
Output short-circuit current	I _{OS}	Applies to all pins except SPM, SPP, V _{DDL} , and V _{DDR} .	10	mA
		Applies to SPM and SPP pins.	300	mA
		Applies to V _{DDL} and V _{DDR} pins.	50	mA
Storage temperature	T _{STG}	—	-55 to +150	°C

RECOMMENDED OPERATING CONDITIONS

(DGND = SPGND = 0 V)

Parameter	Symbol	Condition	Range			Unit
Power supply voltage	DV _{DD} , SPV _{DD}	—	2.7 to 5.5			V
Operating temperature	T _{OP}	—	-40 to +85			°C
Master clock frequency	f _{OSC}	—	Min.	Typ.	Max.	MHz
			3.5	4.096	4.5	
External capacitors for crystal oscillator	Cd, Cg	—	15	30	45	pF

ELECTRICAL CHARACTERISTICS

DC Characteristics (for the 3V applications)

DV_{DD} = SPV_{DD} = 2.7 to 3.6 V, DGND = AGND = 0 V, Ta = -40 to +85°C

Parameter	Symbol	Condition	Min.	Typ.	Max.	Unit
"H" input voltage	V _{IH}	—	0.86×DV _{DD}	—	DV _{DD}	V
"L" input voltage	V _{IL}	—	0	—	0.14×DV _{DD}	V
"H" output voltage 1	V _{OH1}	I _{OH} = -1 mA	DV _{DD} -0.4	—	—	V
"H" output voltage 2 (*1)	V _{OH2}	I _{OH} = -50 μA	DV _{DD} -0.4	—	—	V
"L" output voltage 1	V _{OL1}	I _{OL} = 2 mA	—	—	0.4	V
"L" output voltage 2 (*1)	V _{OL2}	I _{OL} = 50 μA	—	—	0.4	V
"L" output voltage 3 (*2)	V _{OL3}	I _{OL} = 3 mA	—	—	0.4	V
"H" input current 1	I _{IH1}	V _{IH} = DV _{DD}	—	—	10	μA
"H" input current 2 (*3)	I _{IH2}	V _{IH} = DV _{DD}	0.3	2.0	15	μA
"H" input current 3 (*4)	I _{IH3}	V _{IH} = DV _{DD}	2	30	200	μA
"L" input current 1	I _{IL1}	V _{IL} = GND	-10	—	—	μA
"L" input current 2 (*3)	I _{IL2}	V _{IL} = GND	-15	-2.0	-0.3	μA
"L" input current 3 (*5)	I _{IL3}	V _{IL} = GND	-200	-30	-2	μA
"H" output leak current 3 (*6)	I _{ILOH}	V _{OH} = DV _{DD}	—	—	10	μA
"L" output leak current 3 (*6)	I _{ILOL}	V _{OL} = GND	-10	—	—	μA
Supply current during playback	I _{DD}	f _{OSC} = 4.096 MHz No output load	—	—	20	mA
Power-down supply current	I _{DDS}	Ta = -40 to +40°C	—	1	10	μA
		Ta = -40 to +85°C	—	1	20	μA

*1: Applies to the XTb pin.

*2: Applies to the SCL and SDA pins.

*3: Applies to the XT pin.

*4: Applies to the TESTI0 pin.

*5: Applies to the RESETb pin.

*6: Applies to the TESTO pin.

DC Characteristics (for the 5V applications)DV_{DD} = SPV_{DD} = 4.5 to 5.5 V, DGND = SPGND = 0 V, Ta = -40 to +85°C

Parameter	Symbol	Condition	Min.	Typ.	Max.	Unit
"H" input voltage	V _{IH}	—	0.8×DV _{DD}	—	DV _{DD}	V
"L" input voltage	V _{IL}	—	0	—	0.2×DV _{DD}	V
"H" output voltage 1	V _{OH1}	I _{OH} = -1 mA	DV _{DD} -0.4	—	—	V
"H" output voltage 2 (*1)	V _{OH2}	I _{OH} = -50μA	DV _{DD} -0.4	—	—	V
"L" output voltage 1	V _{OL1}	I _{OL} = 2 mA	—	—	0.4	V
"L" output voltage 2 (*1)	V _{OL2}	I _{OL} = 50 μA	—	—	0.4	V
"L" output voltage 3 (*2)	V _{OL3}	I _{OL} = 3 mA	—	—	0.4	V
"H" input current 1	I _{IH1}	V _{IH} = DV _{DD}	—	—	10	μA
"H" input current 2 (*3)	I _{IH2}	V _{IH} = DV _{DD}	0.8	5.0	20	μA
"H" input current 3 (*4)	I _{IH3}	V _{IH} = DV _{DD}	20	100	400	μA
"L" input current 1	I _{IL1}	V _{IL} = GND	-10	—	—	μA
"L" input current 2 (*3)	I _{IL2}	V _{IL} = GND	-20	-5.0	-0.8	μA
"L" input current 3 (*5)	I _{IL3}	V _{IL} = GND	-400	-100	-20	μA
"L" output leak current 2 (*6)	I _{ILOH}	V _{OH} = DV _{DD}	—	—	10	μA
"L" output leak current 3 (*6)	I _{ILOL}	V _{OL} = GND	-10	—	—	μA
Supply current during playback	I _{DD}	f _{OSC} = 4.096 MHz No output load	—	—	25	mA
Power-down supply current	I _{DDS}	Ta = -40 to +40°C	—	1	15	μA
		Ta = -40 to +85°C	—	1	30	μA

*1: Applies to the XTB pin.

*2: Applies to the SCL and SDA pins.

*3: Applies to the XT pin.

*4: Applies to the TESTI0 pin.

*5: Applies to the RESETB pin.

*6: Applies to the TESTO pin.

Characteristics of Analog Circuitry (for the 3V applications)
 $DV_{DD} = SPV_{DD} = 2.7 \text{ to } 3.6 \text{ V}$, $DGND = SPGND = 0 \text{ V}$, $T_a = -40 \text{ to } +85^\circ\text{C}$

Parameter	Symbol	Condition	Min.	Typ.	Max.	Unit
AIN input resistance	R_{AIN}	—	15	20	25	$k\Omega$
AIN input voltage range	V_{AIN}		—	—	$DV_{DD} \times 2/3$	Vp-p
LINE output load resistance	R_{LA}	During 1/2 DV_{DD} output	10	—	—	$k\Omega$
LINE output voltage range	V_{AO}	No output load	$DV_{DD}/6$	—	$DV_{DD} \times 5/6$	V
SG output voltage	V_{SG}	—	$0.95 \times V_{DDL}/2$	$V_{DDL}/2$	$1.05 \times V_{DDL}/2$	V
SG output resistance	R_{SG}	During power down	57	96	135	$k\Omega$
SPM, SPP output load resistance	R_{LSP}	—	8	—	—	Ω
Speaker amplifier output power	P_{SPO}	$SPV_{DD} = 3.3\text{V}$, $f = 1\text{kHz}$ $R_{SPO} = 8\Omega$, $THD \geq 10\%$	100	300	—	mW
Output offset voltage between SPM and SPP with no signal present	V_{OF}	SPIN–SPM gain = 0dB With a load of 8Ω	–50	—	+50	mV

Characteristics of Analog Circuitry (for the 5V applications)
 $DV_{DD} = SPV_{DD} = 4.5 \text{ to } 5.5 \text{ V}$, $DGND = SPGND = 0 \text{ V}$, $T_a = -40 \text{ to } +85^\circ\text{C}$

Parameter	Symbol	Condition	Min.	Typ.	Max.	Unit
AIN input resistance	R_{AIN}	—	15	20	25	$k\Omega$
AIN input voltage range	V_{AIN}		—	—	$DV_{DD} \times 2/3$	Vp-p
LINE output load resistance	R_{LA}	During 1/2 DV_{DD} output	10	—	—	$k\Omega$
LINE output voltage range	V_{AO}	No output load	$DV_{DD}/6$	—	$DV_{DD} \times 5/6$	V
SG output voltage	V_{SG}	—	$0.95 \times V_{DDL}/2$	$V_{DDL}/2$	$1.05 \times V_{DDL}/2$	V
SG output resistance	R_{SG}	During power down	57	96	135	$k\Omega$
SPM, SPP output load resistance	R_{LSP}	—	8	—	—	Ω
Speaker amplifier output power	P_{SPO}	$SPV_{DD} = 5.0\text{V}$, $f = 1\text{kHz}$ $R_{SPO} = 8\Omega$, $THD \geq 10\%$ $T_a = 25^\circ\text{C}$	500	700	—	mW
Output offset voltage between SPM and SPP with no signal present	V_{OF}	SPIN–SPM gain = 0dB With a load of 8Ω	–50	—	+50	mV

AC Characteristics (Common to All Products)DV_{DD} = SPV_{DD} = 2.7 to 5.5 V, DGND = SPGND = 0 V, Ta = -40 to +85°C

Parameter	Applicable command	Symbol	Condition	Min.	Typ.	Max.	Unit
Master clock duty cycle		f _{duty}	—	40	50	60	%
RESETB input pulse width		t _{RST}	—	100	—	—	μs
Reset noise rejection pulse width		t _{NRST}	—	—	—	0.1	μs
Command input interval time	STOP, SLOOP, CLOOP, CVOL, AVOL	t _{INT}	f _{OSC} = 4.096 MHz	2	—	—	μs
	PUP	t _{INTP}		10	—	—	ms
	RDSTAT (After status read)	t _{INTRD}		500	—	—	μs
Command input enable time	SLOOP (Continuous play by PLAY/MUON)	t _{cm}	f _{OSC} = 4.096 MHz	—	—	10	ms
CBUSYB "L" level output time	PUP	t _{PUP1}	f _{OSC} = 4.096 MHz	2.0	2.5	3.0	ms
	PDWN	t _{PD1}	f _{OSC} = 4.096 MHz	—	—	20	μs
	2nd byte of AMODE (PUP = "0" SPEN = "0", DAEN = "0" → "1")	t _{PUPA1}	f _{OSC} = 4.096 MHz When an external clock is input	58	60	62	ms
	2nd byte of AMODE (PUP = "1" SPEN = "0", DAEN = "0" → "1")	t _{PUPA2}	f _{OSC} = 4.096 MHz	90	93	95	ms
	2nd byte of AMODE (SPEN = "0" → "1")	t _{POPA3}	f _{OSC} = 4.096 MHz AVOL="0Eh~3Fh"	46 ^{*2}	60 ^{*3}	70 ^{*4}	ms
	2nd byte of AMODE (PUP = "0" SPEN = "0", DAEN = "1" → "0")	t _{PDA1}	f _{OSC} = 4.096 MHz	108	110	112	ms
	2nd byte of AMODE (PUP = "1" SPEN = "0", DAEN = "1" → "0")	t _{PDA2}	f _{OSC} = 4.096 MHz	140	142	144	ms
	2nd byte of AMODE (SPEN = "1" → "0")	t _{PDA3}	f _{OSC} = 4.096 MHz AVOL="0Eh~3Fh"	0.2 ^{*2}	6.5 ^{*3}	17 ^{*4}	ms
CBUSYB "L" level output time 1(*1)		t _{CB1}	f _{OSC} = 4.096 MHz	—	—	2	ms

Note: Output pin load capacitance = 45 pF

*1: Applies to the case that a command is input except after a PUP, PDWN, or 2nd byte of AMODE command input.

*2: The value when AVOL="0Eh" is set.

*3: The value when AVOL="23h" is set.

*4: The value when AVOL="3Fh" is set.

AC Characteristics of Synchronous Serial Command Interface (Applied to ML2272X)DV_{DD} = SPV_{DD} = 2.7 to 5.5 V, DGND = SPGND = 0 V, Ta = -40 to +85°C

Parameter	Applicable command	Symbol	Condition	Min.	Typ.	Max.	Unit
SCK input enable time from CSB fall edge		t _{ESCK}	—	100	—	—	ns
SCK hold time from CSB rise edge		t _{CSH}	—	100	—	—	ns
Data floating time from CSB rise edge		t _{DOZ}	R _L = 3 kΩ	—	—	100	ns
Data setup time from SCK rise edge		t _{DIS1}	DIPH = "0"	50	—	—	ns
Data hold time from SCK rise edge		t _{DIH1}	DIPH = "0"	50	—	—	ns
Data output delay time from SCK fall edge		t _{DOD1}	R _L = 3 kΩ	—	—	80	ns
Data setup time from SCK fall edge		t _{DIS2}	DIPH = "1"	50	—	—	ns
Data hold time from SCK fall edge		t _{DIH2}	DIPH = "1"	50	—	—	ns
Data output delay time from SCK rise edge		t _{DOD2}	R _L = 3 kΩ	—	—	80	ns
SCK "H" level pulse width		t _{SCKH}	—	100	—	—	ns
SCK "L" level pulse width		t _{SCKL}	—	100	—	—	ns
CBUSYB output delay time from SCK rise edge		t _{DBSY1}	DIPH = "0"	—	—	150	ns
CBUSYB output delay time from SCK fall edge		t _{DBSY2}	DIPH = "1"	—	—	150	ns

Note: Output pin load capacitance = 45 pF**AC Characteristics of I2C Command Interface (Applied to ML2276X)**DV_{DD} = SPV_{DD} = 2.7 to 5.5 V, DGND = SPGND = 0 V, Ta = -40 to +85°C

Parameter	Symbol	(High-speed mode)		Unit
		Min.	Max.	
SCL clock frequency	t _{SCL}	0	400	kHz
Hold time for (repeated) START condition After this period, the first clock pulse is generated.	T _{HD;STA}	0.6	—	μs
SCL "L" level pulse width	t _{LOW}	1.3	—	μs
SCL "H" level pulse width	t _{HIGH}	0.6	—	μs
Setup time for repeated START condition	t _{SU;STA}	0.6	—	μs
Data hold time: For I2C bus devices	t _{HD;DAT}	0	0.9	μs
Data setup time	t _{SU;DAT}	100	—	ns
SDA and SCL signal rise time	t _r	20	300	ns
SDA and SCL signal fall time	t _f	20	300	ns
Setup time for STOP condition	t _{SU;STO}	0.6	—	μs
Bus free time between STOP condition and START condition	t _{BUF}	1.3	—	μs
Capacitive load for each bus line	C _b	—	400	PF
Noise margin at a "L" level in each device connected (including hysteresis)	V _{nL}	0.1× DV _{DD}	—	V
Noise margin at a "H" level in each device connected (including hysteresis)	V _{nH}	0.1× DV _{DD}	—	V

Note: Output pin load capacitance = 45 pF

TIMING DIAGRAMS (3-WIRED SERIAL CLOCK-SYNCHRONIZED (ML2272X))

Power-On Timing

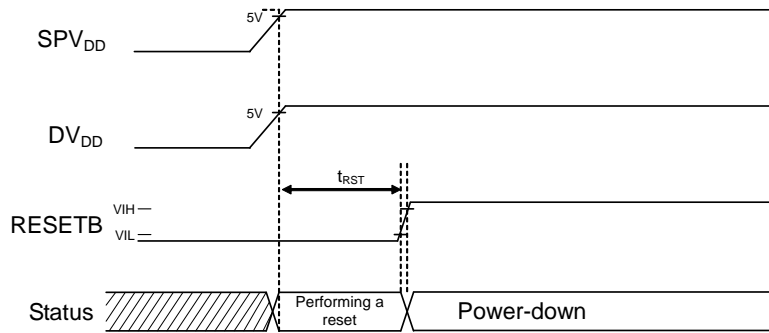

Oscillation is stopped after power-on.

Power-Up Timing

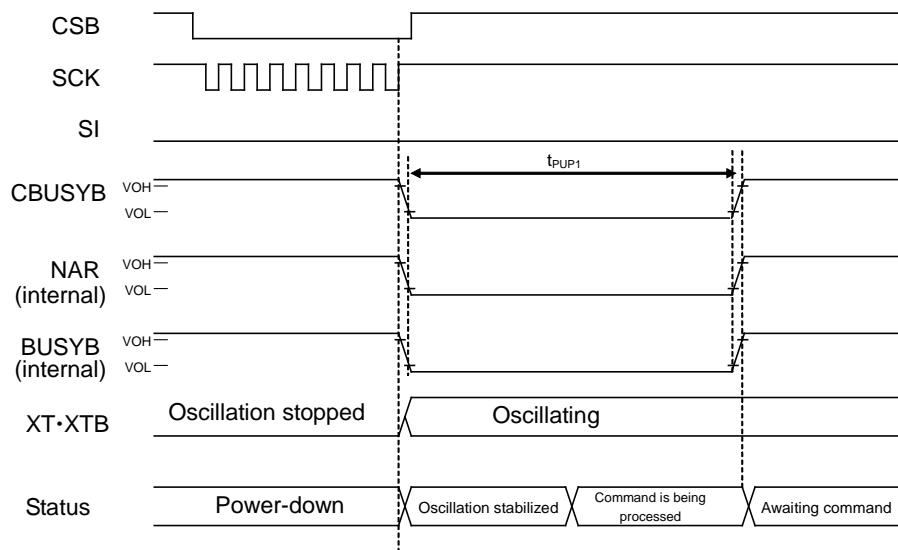

Power-Down Timing (At the PDWN command Input)

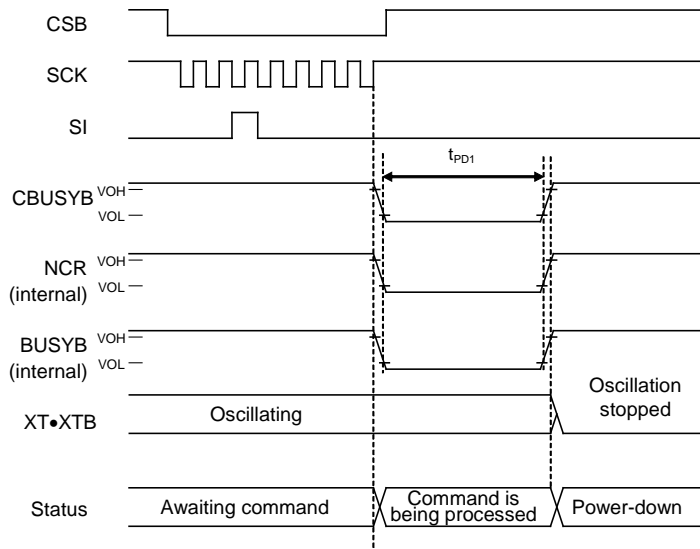

Power-Down Timing (At the RESETB Input)

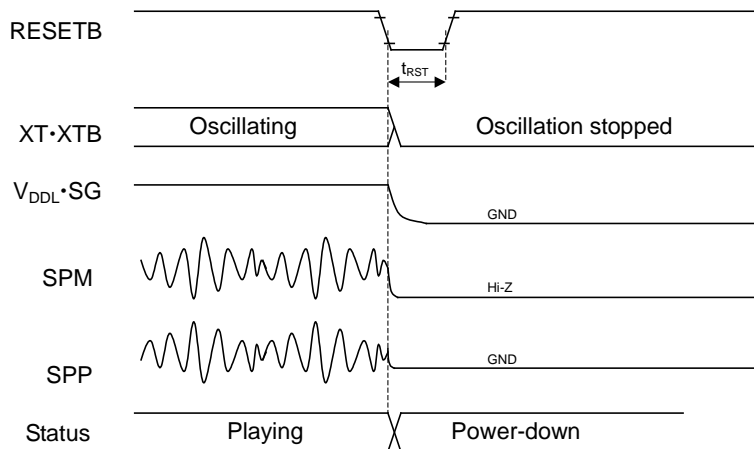

Note: The same timing is applied in the case that the RESETB signal is input during command waiting.

Playback Start Timing by the PLAY Command

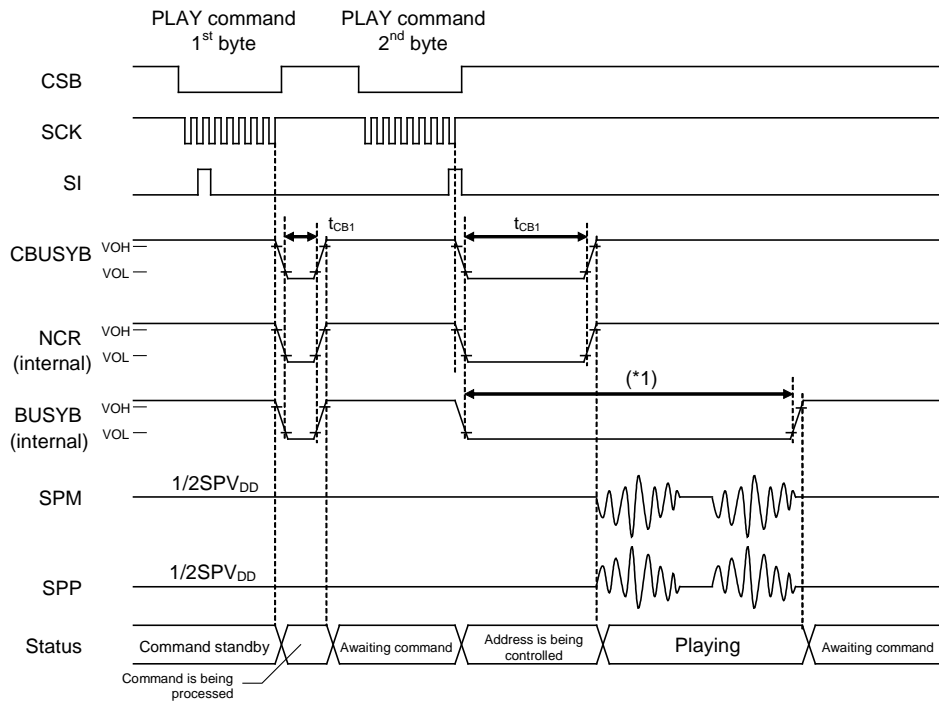

Note: The time length of “L” level of BUSYB is t_{CB1} + voice reproduction time + 12ms.

Playback Stop Timing

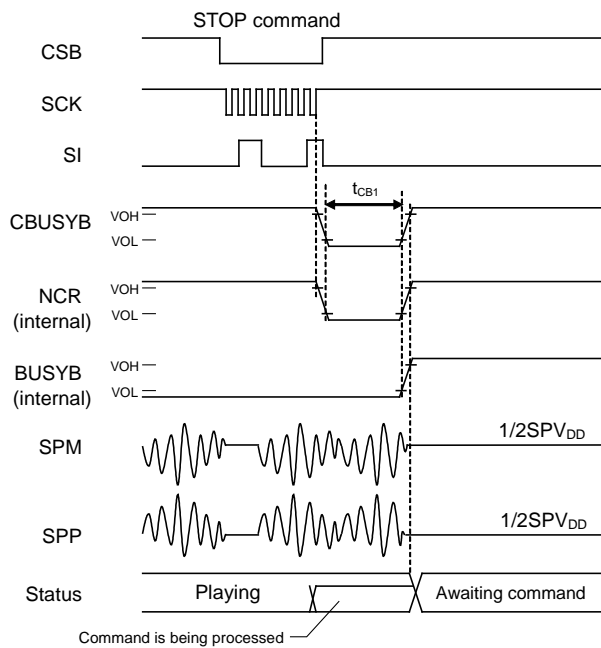

Continuous Playback Timing by the PLAY Command

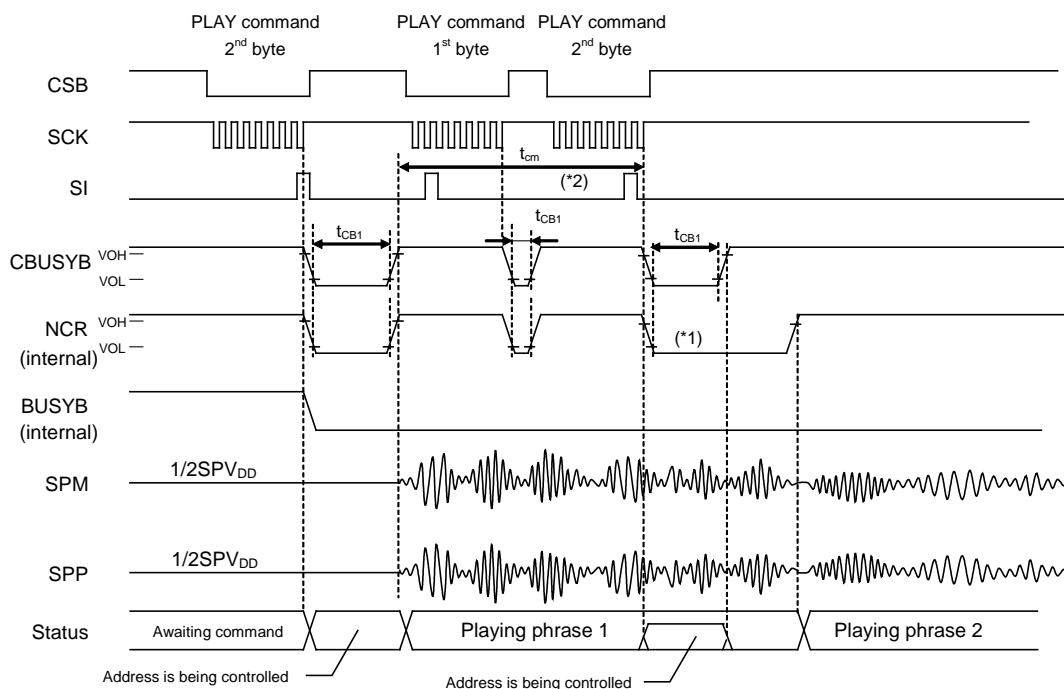

*1: The time length of “L” level of the NCR signal during playback varies depending on the input timing of command.

*2: The following PLAY command must be inputted within t_{cm} . When it cannot, please input the phrase 2 PLAY command after checking that BUSYB became “H”(phrase 1 playback has been finished).

Continuous Playback Timing by the START Command

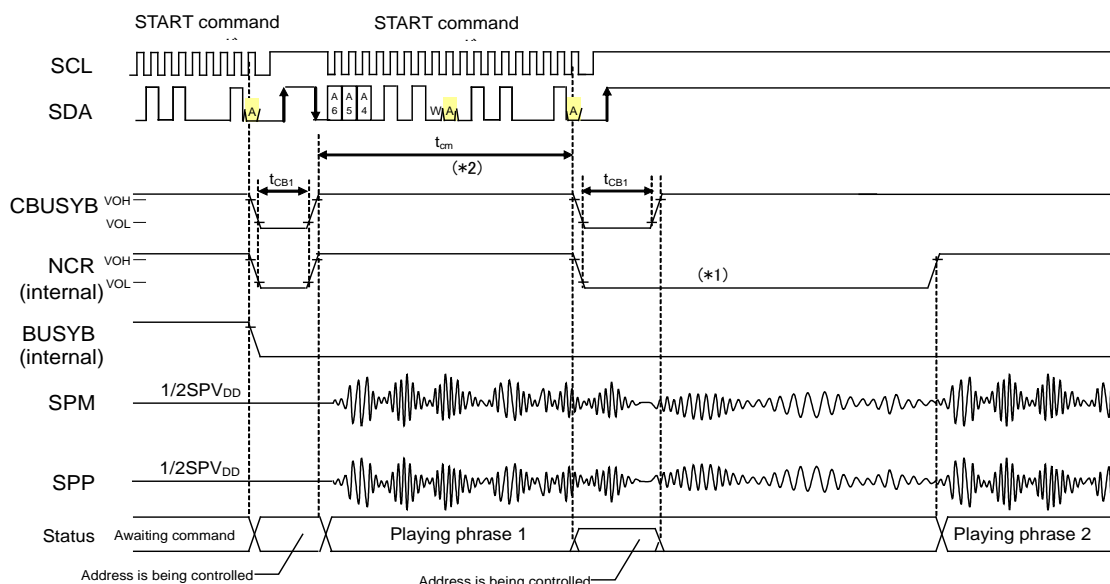

*1: The time length of “L” level of the NCR signal during playback varies depending on the input timing of command.

*2: Please input the following START command within t_{cm} . When it cannot, please input the phrase 2 START command after checking that BUSYB became “H”(phrase 1 playback has been finished).

Silence Insertion Timing by the MUON Command

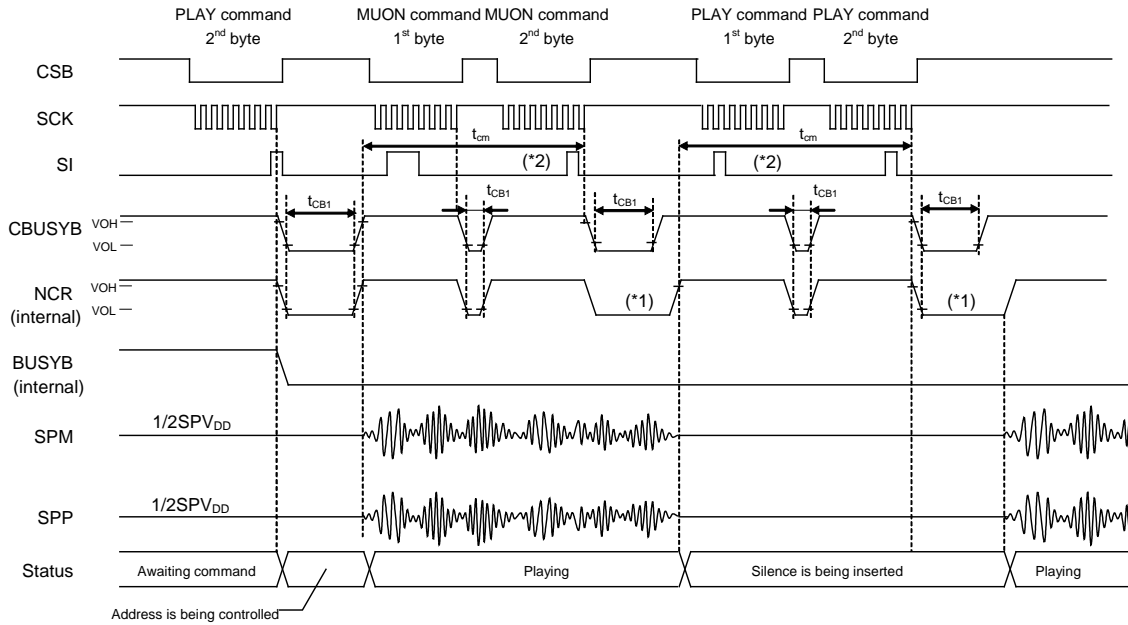

*1: The time length of “L” level of the NCR signal during playback or silence insertion varies depending on the input timing of command.

*2: The following MUON command or PLAY command must be inputted within t_{cm} . When it cannot, please input the MUON command or PLAY command after checking that BUSYB became “H”(playback has been finished).

Repeat Playback Set/Release Timing by the SLOOP and CLOOP Commands

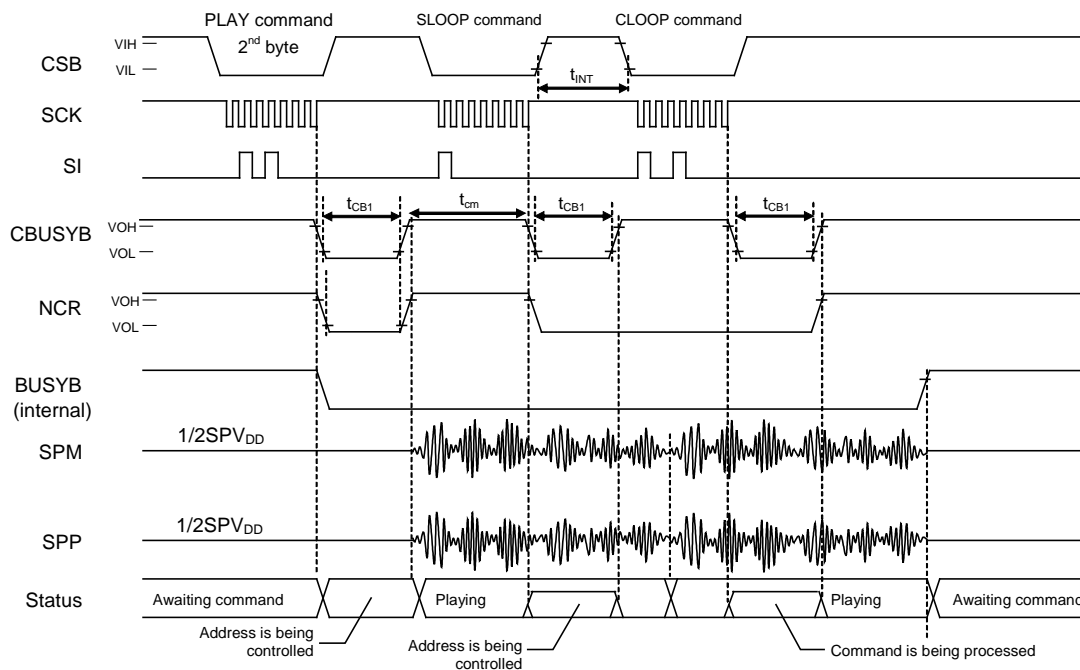

*1: The SLOOP command must be inputted within t_{cm} .

Timing of Volume Change by the CVOL Command

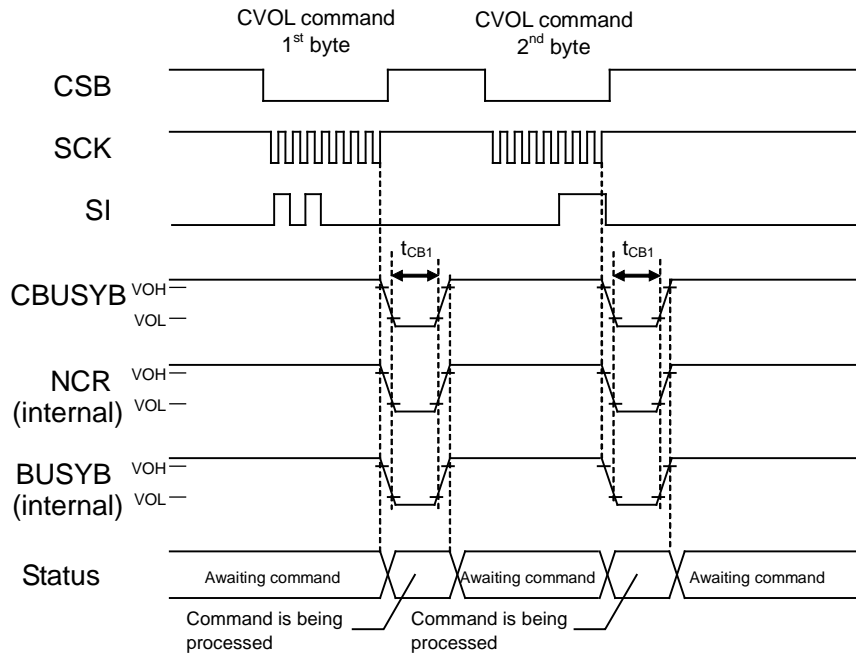

Timing of Volume Change by the AVOL Command

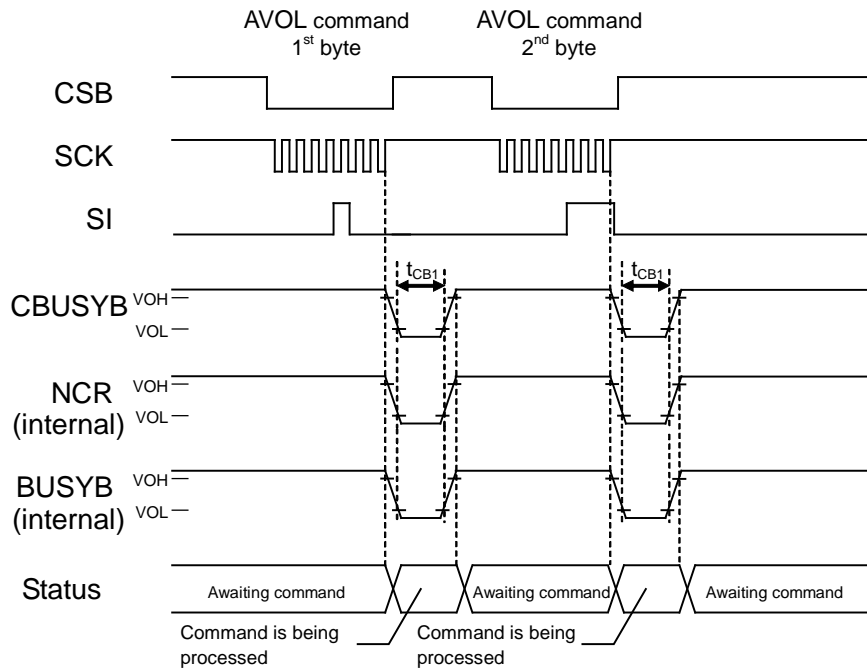

TIMING DIAGRAMS (I2C INTERFACE (ML2276X))

Power-On Timing

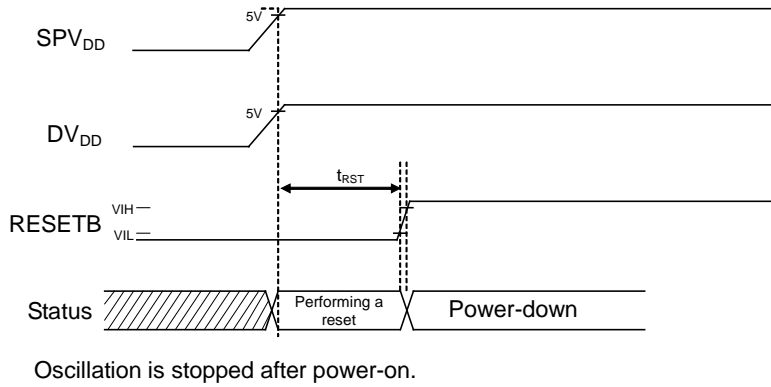

Power-Up Timing

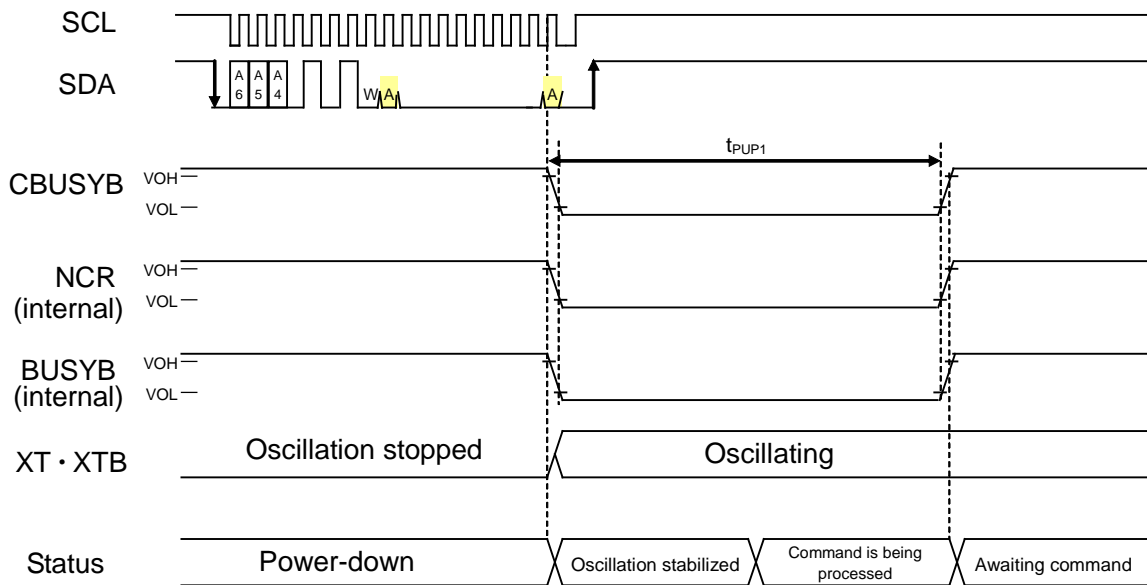

Power-Down Timing (At the PDWN command Input)

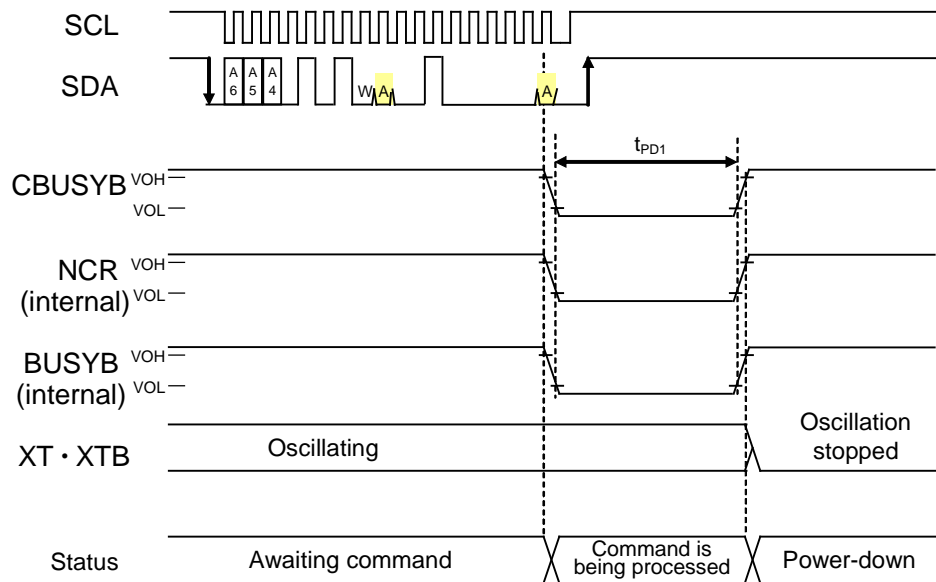

Power-Down Timing (At the RESETB Input)

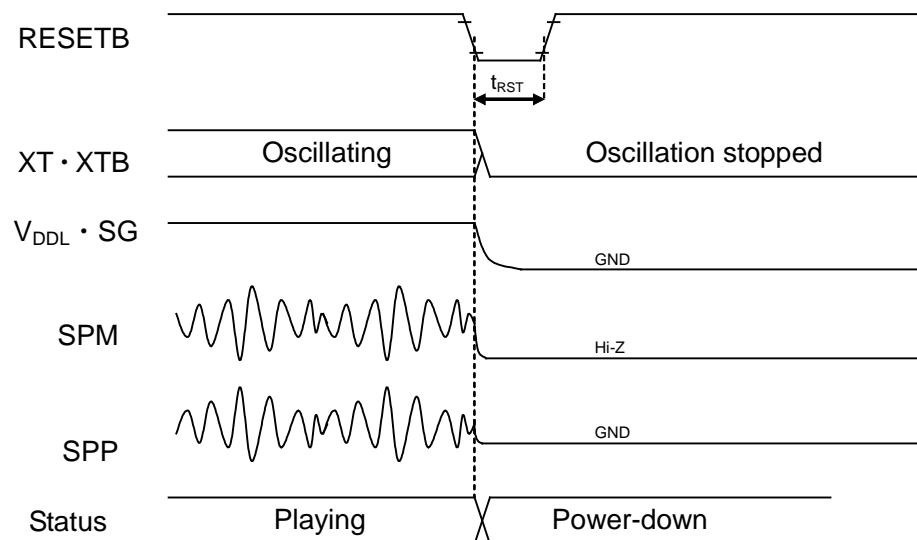

Note: The same timing is applied in the case that the RESETB signal is input during command waiting.

Playback Start Timing by the PLAY Command

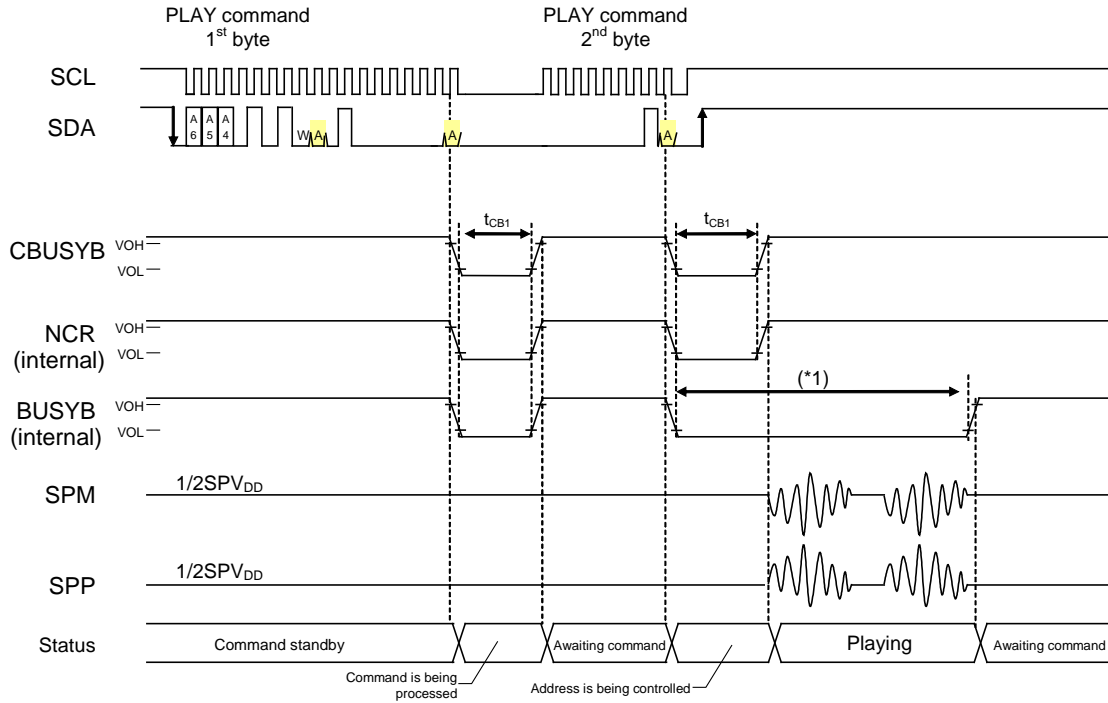

*1: The maximum length of the “L” interval of BUSYB is $t_{CB1} + \text{voice reproduction time} + 12\text{ms}$.

Playback Stop Timing

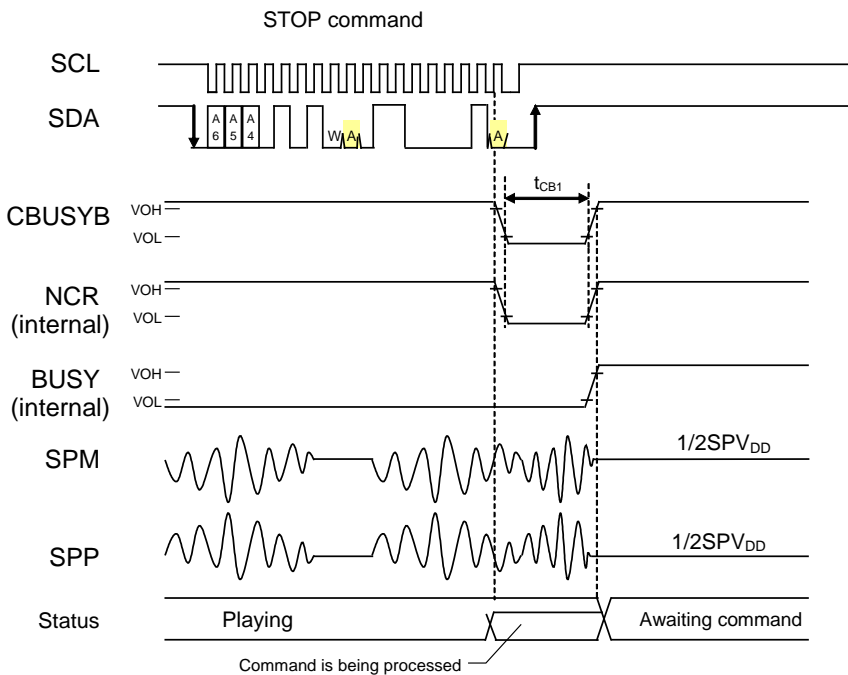

Continuous Playback Timing by the PLAY Command

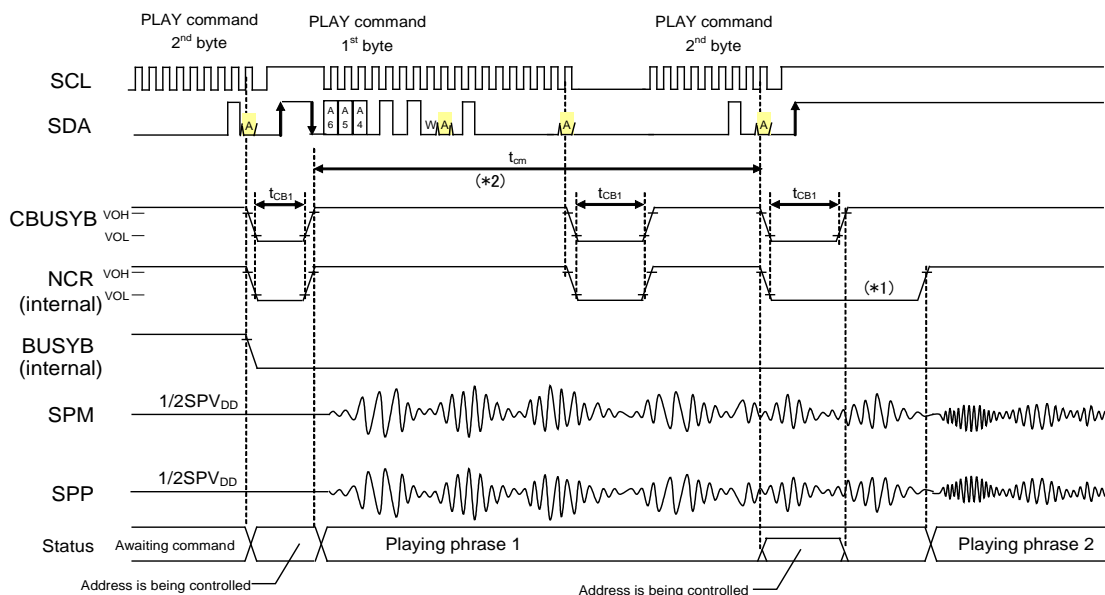

- *1: The time length of “L” level of the NCR signal during playback varies depending on the input timing of command.
- *2: The following PLAY command must be inputted within t_{cm} . When it cannot, please input the phrase 2 PLAY command after checking that BUSYB became “H”(phrase 1 playback has been finished).

Continuous Playback Timing by the START Command

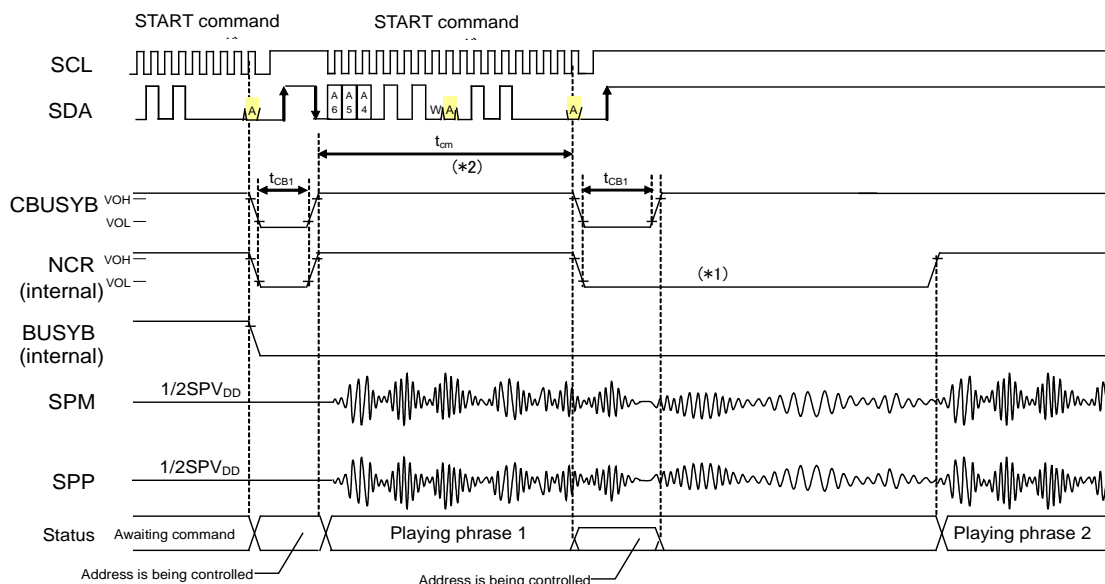

- *1: The time length of “L” level of the NCR signal during playback varies depending on the input timing of command.
- *2: Please input the following START command within t_{cm} . When it cannot, please input the phrase 2 START command after checking that BUSYB became “H”(phrase 1 playback has been finished).

Silence Insertion Timing by the MUON Command

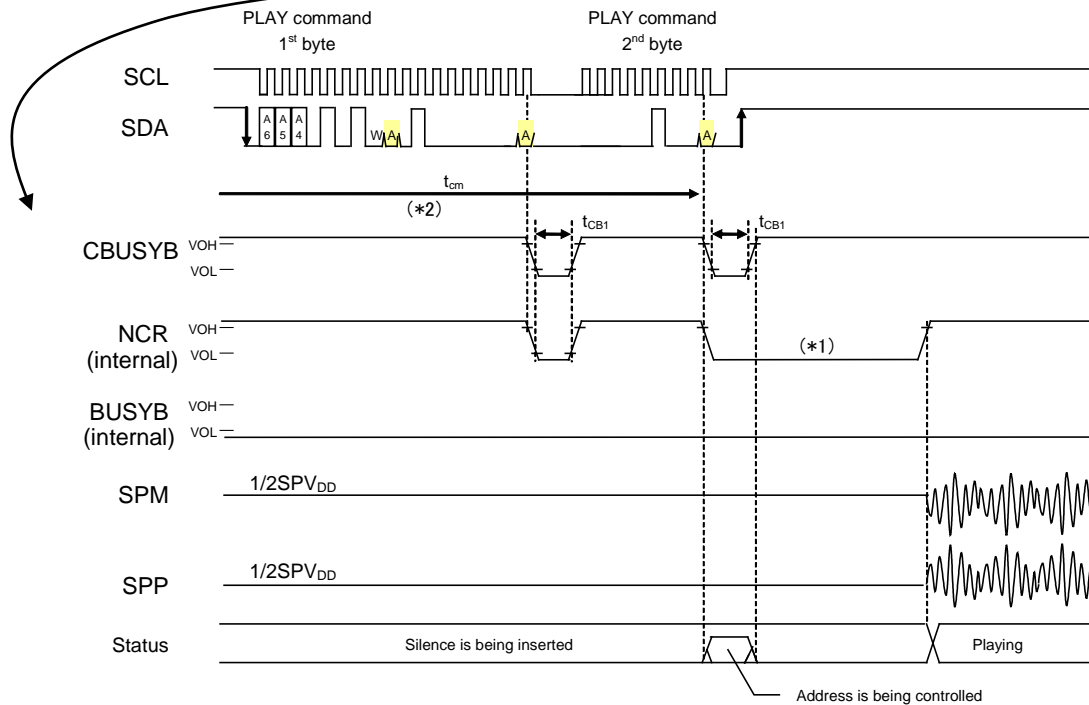
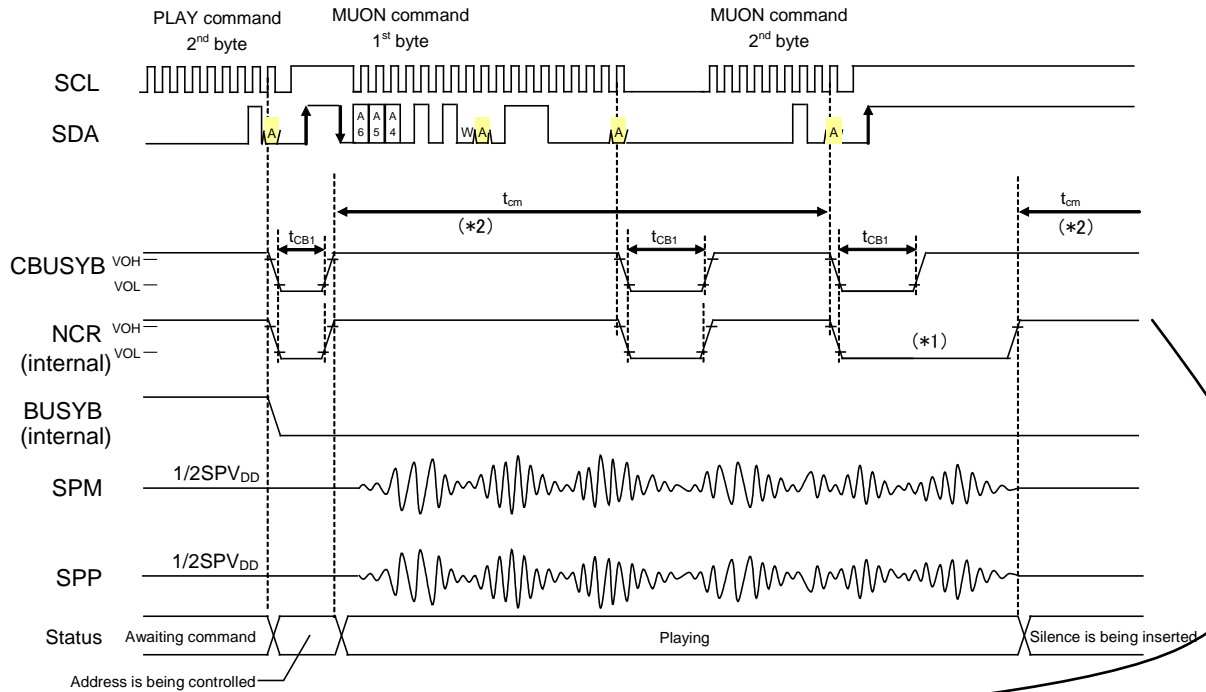

*1: The time length of “L” level of the NCR signal during playback or silence insertion varies depending on the input timing of command.

*2: Please input the following MUON command or PLAY command within t_{cm} . When it cannot, please input the MUON command or PLAY command after checking that BUSYB became “H”(playback has been finished).

Repeat Playback Set/Release Timing by the SLOOP and CLOOP Commands

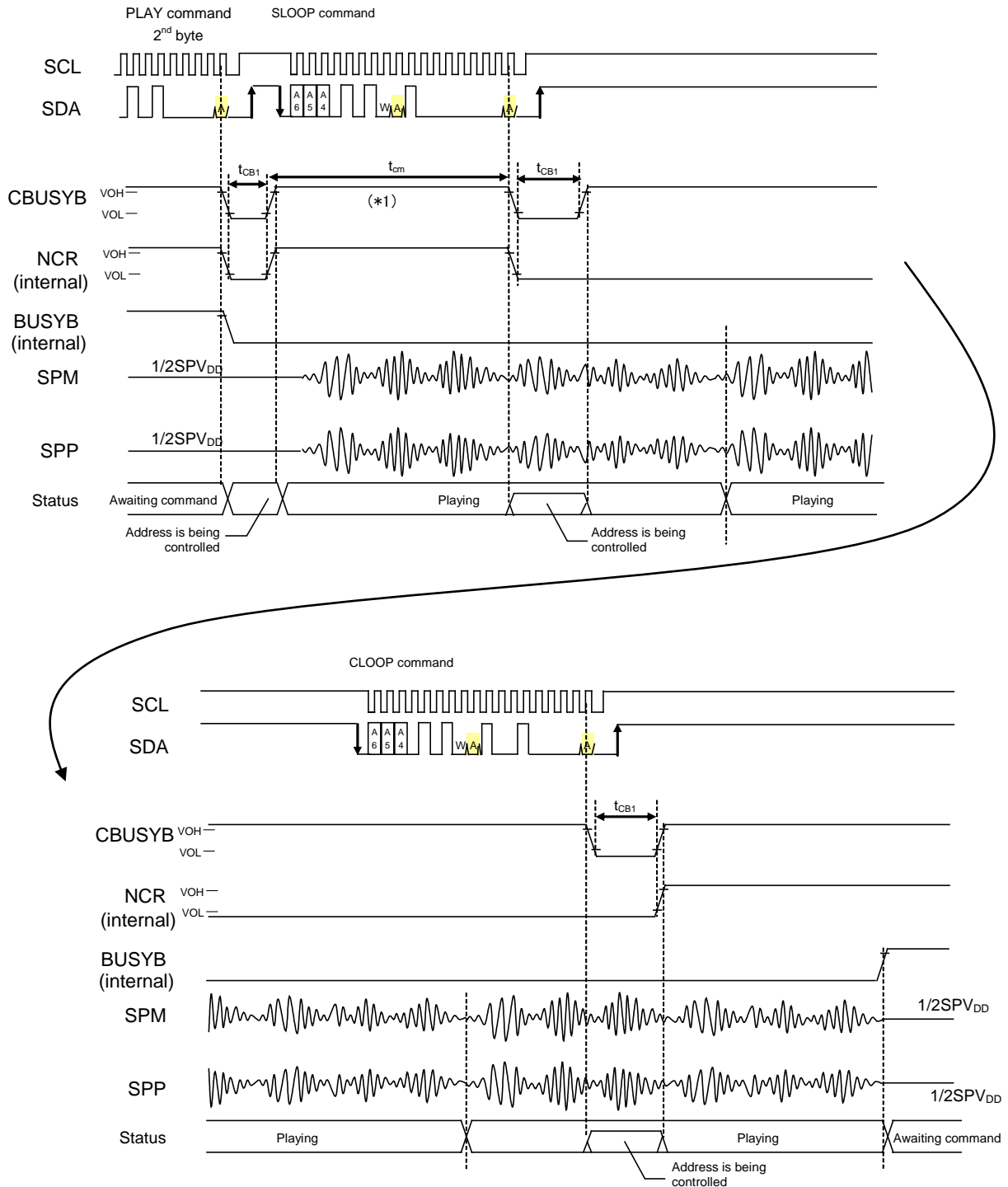

*1: The SLOOP command must be inputted within t_{cm} .

Timing of Volume Change by the CVOL Command

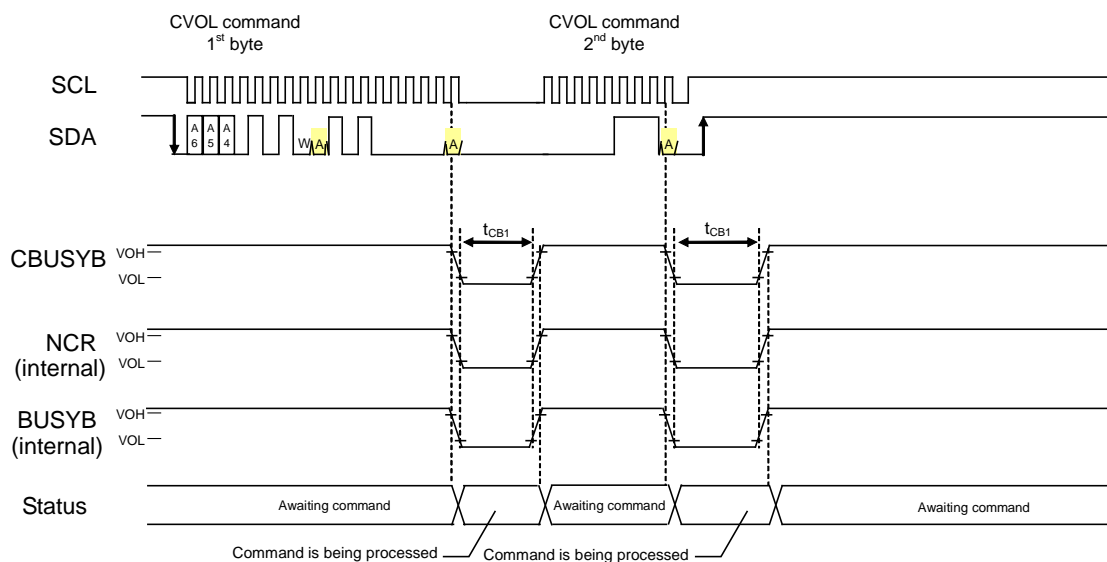

Timing of Volume Change by the AVOL Command

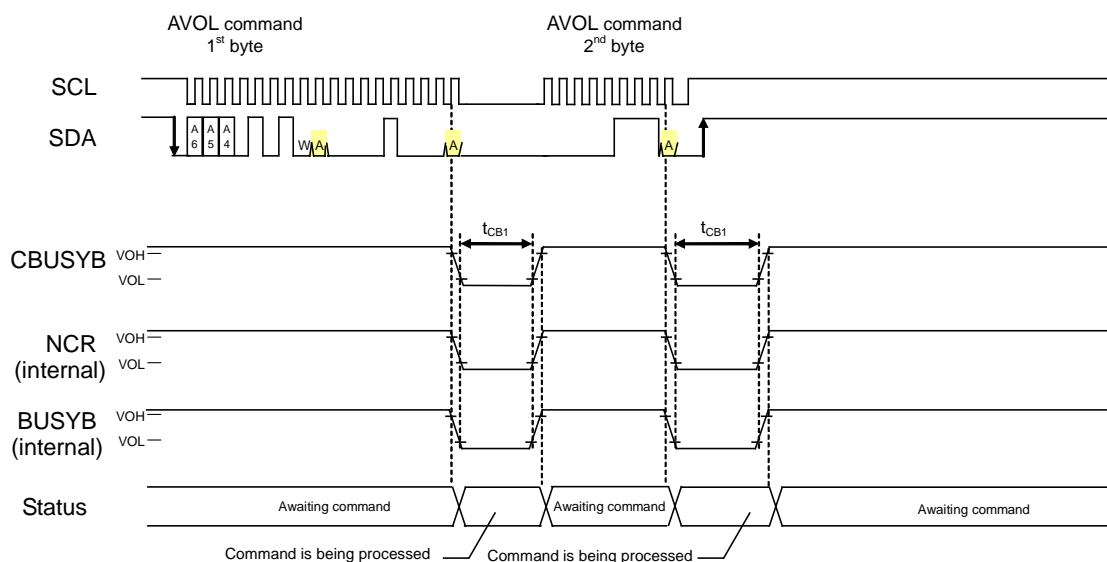

Serial Command Interface Timing (Applied to ML2272X)
 when DIPH pin is “L” level (Rise edge for input, fall edge for output)

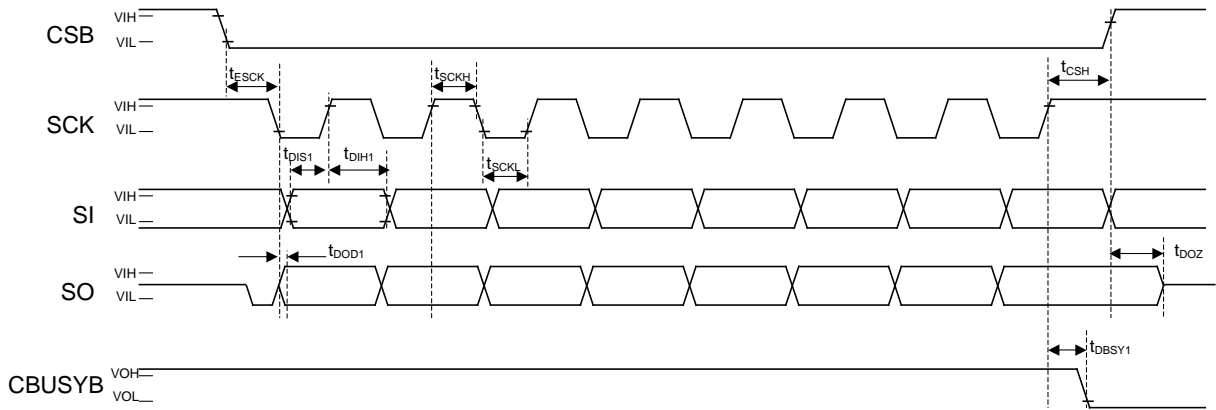

Serial Command Interface Timing (Applied to ML2272X)
 when DIPH pin is “H” level (Fall edge for input, rise edge for output)

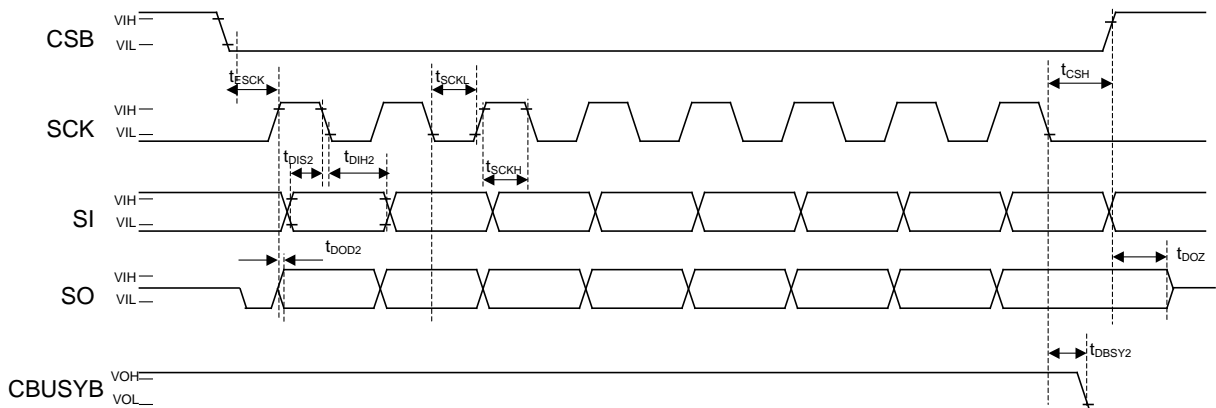

I2C Command Interface Timing (Applied to ML2276X)

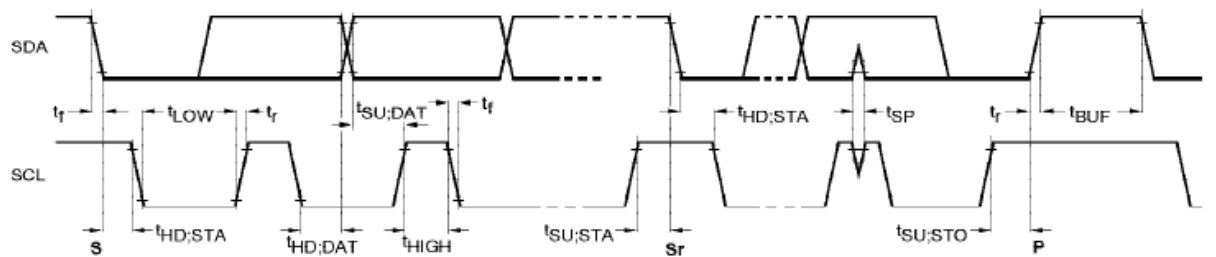

FUNCTIONAL DESCRIPTION

Synchronous Serial Command Interface (Applied to ML2272X)

The CSB, SCK, SI, and SO pins are used to input the command data or to read the status. Driving the CSB pin to “L” level enables the serial CPU interface.

After the CSB pin is driven to “L” level, the command data are input through the SI pin from the MSB synchronized with the SCK clock. The command data shifts in through the SI pin at the rising or falling edge of the SCK clock pulse. Then, a command is executed at the rising or falling edge of the eighth pulse of the SCK clock.

As for status reading, status is output from the SO pin, synchronized with the SCK clock after the CSB pin is driven to “L” level.

The SCK clock edge is specified by the input level of the DIPH pin.

- When the DIPH pin is “L” level, rising edge is available for input from SI pin and falling edge is available for output from SO pin.
- When the DIPH pin is “H” level, falling edge is available for input from SI pin and rising edge is available for output from SO pin.

It is possible to input command data, even if the CSB pin is fixed by “L” level. However, if unexpected pulses caused by noise are induced through the SCK pin, SCK clock pulses are incorrectly counted, causing a failure in normal recognition of command. Then it is recommended that the CSB pin is “L” level only for command input.

The count of the SCK clock pulse is initialized when the CSB pin goes to “H” level.

Command Data Input or Status Read Timing

- When DIPH pin is “L” level

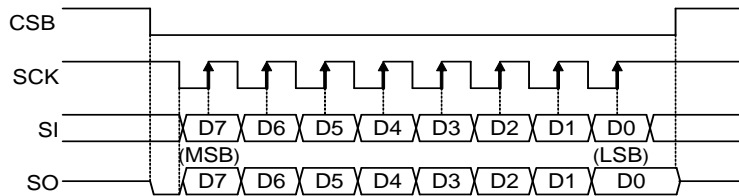

- When DIPH pin is “H” level

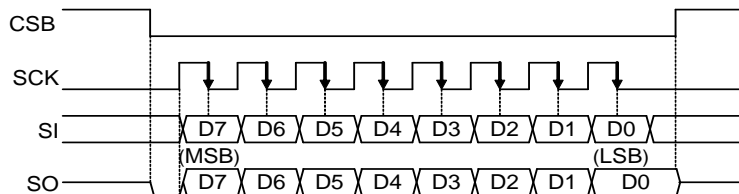

The following table shows the contents of each data output at a status read.

	Output status signal
MSB	—
7SB	—
6SB	—
5SB	BUSYB output
4SB	—
3SB	—
2SB	—
LSB	NCR output

The BUSYB output is “L” level when a command is being processed or playback is going on. In other states, the BUSYB output is “H” level. The NCR signal output is “L” level when a command is being processed or playback is in a standby state. In other states, the NCR output is “H” level.

I2C Command Interface (Applied to ML2276X)

The I2C Interface built-in is an serial interface (: slave side) that is compliant with I2C bus specification. It supports Fast mode and enables data transmission/reception at 400 kbps. The SCL and SDA pins are used to input the command data or to read the status. Pins (:SAD0, 1 and 2) are used to set the slave address. Pull-up resistor should be connected to SCL pin and SDA pin.

For the master on the I2C bus to communicate with this device (: slave), input the slave address with the first seven bits after setting the start condition. The upper three bits of the slave address can be set using the SAD0 to 2 pins. The eighth bit of slave address is used to set the direction (: write or read) of communication. If the eighth bit is “0” level, it is write mode from master to slave. And, if the eighth bit is “1” level, it is read mode from master.

The communication is made in the unit of byte. And acknowledge is needed for each byte.

The protocol of I2C communication is shown below.

24 Command flow at data write

- Start condition
- Slave address +W(0)
- Write address (ex. 1st byte of a command)
- Write data (ex. 2nd byte of a command)
- STOP condition

• Data write timing

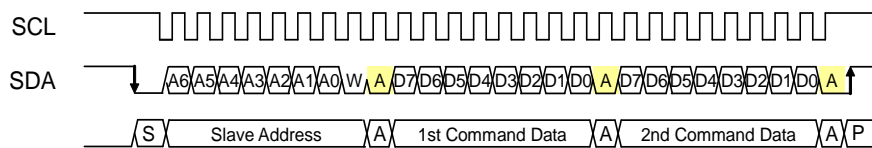

24 Command flow at the data read

- Start condition
- Slave address +R (1)
- Read data (ex. Status read)
- STOP condition

• Data read timing

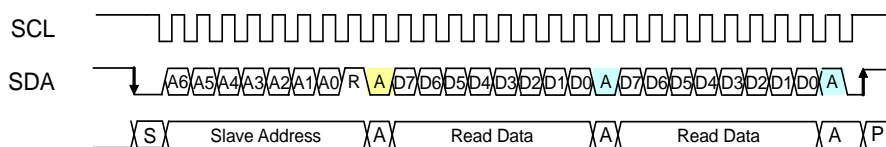

Setting of the slave address using the SAD0 to 2 pins

SAD2	SAD1	SAD0	Lower 4 bits
0	0	0	0101
0	0	1	0101
0	1	0	0101
0	1	1	0101
1	0	0	0101
1	0	1	0101
1	1	0	0101
1	1	1	0101

The following table shows the contents of each data output at the status read. Status is updated by the RDSTAT command, therefore, be sure to input the RDSTAT command in order to read status.

	Output status signal
MSB	
7SB	
6SB	
5SB	BUSYB output (BUSYB0)
4SB	
3SB	
2SB	
LSB	NCR output (NCR0)

The BUSYB signal is “L” level when either a command is being processed or the playback of a particular channel is going on. In other states, the BUSYB signal is “H” level. The NCR signal is “L” level when either a command is being processed or a particular channel is in standby for playback. In other states, the NCR signal is “H” level.

Command List

Each command is configured in 1-byte (8-bit) units. Each of the AMODE, AVOL FADR, PLAY, MUON, CVOL, VPITCH, and VSPD commands forms one command by two bytes.

Command	D7	D6	D5	D4	D3	D2	D1	D0	Description
PUP	0	0	0	0	0	0	S1	S0	Power-up command. Shift from the power down state to the command waiting state. Also, sets the number of memory banks.
PDWN	0	0	1	0	0	0	0	0	Power-down command. Shift from the command waiting state to the power down state.
RDSTAT	1	0	1	1	0	0	0	0	Status read command. Read the command status.
AMODE	0	0	0	0	0	1	0	0	Control command of analog circuitry. Set operation of power-up/dpwn and input/output.
	FAD	DAG1	DAG0	AIG1	AIG0	DAEN	SPEN	POP	
PLAY	0	1	0	0	F9	F8	0	0	Playback start command. Use the data of the 2 nd byte to specify a phrase number.
	F7	F6	F5	F4	F3	F2	F1	F0	
STOP	0	1	1	0	0	0	0	0	Playback stop command.
FADR	0	0	1	1	F9	F8	0	0	Set command of playback phrase. Use START command to start.
	F7	F6	F5	F4	F3	F2	F1	F0	
START	0	1	0	1	0	0	0	0	Playback start command without phrase spec. Use FADR command to set phrase. After played back by PLAY command, the same phrase can be played back with this command.
MUON	0	1	1	1	0	0	0	0	Silence insertion command. Set the silent time length using M7 to M0 bits in the 2 nd byte.
	M7	M6	M5	M4	M3	M2	M1	M0	
SLOOP	1	0	0	0	0	0	0	0	Set command of repeat playback. Setting is enabled during playback.
CLOOP	1	0	0	1	0	0	0	0	Stop command of repeat playback. Also, repeat playback is released by STOP command automatically.
CVOL	1	0	1	0	0	0	0	0	Volume control command. Set volume using CV4 to CV0 bits in the 2 nd byte.
	0	0	0	CV4	CV3	CV2	CV1	CV0	
AVOL	0	0	0	0	1	0	0	0	Analog volume control command. Set volume using AV5 to AV0 bits.
	0	0	AV5	AV4	AV3	AV2	AV1	AV0	
VPITCH	1	1	1	0	0	0	0	0	Pitch conversion command. Can be specified pitch.
	PI7	PI6	PI5	PI4	PI3	PI2	PI1	PI0	
VSPD	1	1	0	1	0	0	0	0	Speech speed conversion command. Can be specified speed.
	SD7	SD6	SD5	SD4	SD3	SD2	SD1	SD0	

Voice Synthesis Algorithm

Four types of voice synthesis algorithm are supported. They are 4-bit ADPCM2, 8-bit non-linear PCM, 8-bit straight PCM and 16-bit straight PCM. Select the best one according to the characteristics of playback voice.

The following table shows key features of each algorithm.

Voice synthesis algorithm	Applied waveform	Feature
4-bit ADPCM2	Normal voice waveform	Up version of LAPIS Semiconductor's specific voice synthesis algorithm (:4-bit ADPCM). Voice quality is improved.
8-bit Nonlinear PCM	Waveform including high frequency signals (sound effect, etc.)	Algorithm which plays back mid-range of waveform as 10-bit equivalent voice quality.
8-bit straight PCM		Normal 8-bit PCM algorithm.
16-bit straight PCM		Normal 16-bit PCM algorithm,

Memory Allocation and Creating Voice Data

The ROM is partitioned into four data areas: voice (i.e., phrase) control area, test area, voice area, and edit ROM area.

The voice control area manages the voice data in the ROM. It contains data for controlling the start/stop addresses of voice data for 1,024 phrases, use/non-use of the edit ROM function and so on.

The test area contains data for testing.

The voice area contains actual waveform data.

The edit ROM area contains data for effective use of voice data. For the details, refer to the section of “Edit ROM Function.”

The edit ROM area is not available if the edit ROM is not used.

The ROM data is created using a dedicated tool.

Configuration of ROM data

0x00000	Voice control area (Fixed 64 Kbits)
0x01FFF	
0x02000	Test area
0x0205F	
0x02060	Voice area
max: 0x1FFFFF	
max: 0x1FFFFF	
	Edit ROM area Depends on creation of ROM data.

Playback Time and Memory Capacity

The playback time depends on the memory capacity, sampling frequency, and playback method.

The equation to know the playback time is shown below. But this is not applied if the edit ROM function is used.

$$\text{Playback time [sec]} = \frac{1.024 \times (\text{Memory capacity} - 64.75 \text{ [Kbits]})}{\text{Sampling frequency [kHz]} \times \text{Bit length}}$$

(Bit length is 4 at the 4-bit ADPCM2 and 8/16 at the PCM.)

Example) In the case that the sampling frequency is 16 kHz, algorithm is 4-bit ADPCM2 and ROM capacity is 16 Mbits, the playback time is approx. 261 seconds, as shown below.

$$\text{Playback time} = \frac{1.024 \times (16834 - 64.75) \text{ [Kbits]}}{16 \text{ [kHz]} \times 4 \text{ [bits]}} \cong 261 \text{ [sec]}$$

Edit ROM Function

The edit ROM function makes it possible to play back multiple phrases in succession. The following functions are set using the edit ROM function:

- Continuous playback: There is no limit to set the number of times of continuous playback. It depends on the memory capacity only.
- Silence insertion: 20ms to 1,024 ms (4ms/step)

It is possible to use voice ROM effectively to use the edit ROM function. Below is an example of the ROM structure, case of using the edit ROM function.

Example 1) Phrases using the Edit ROM Function

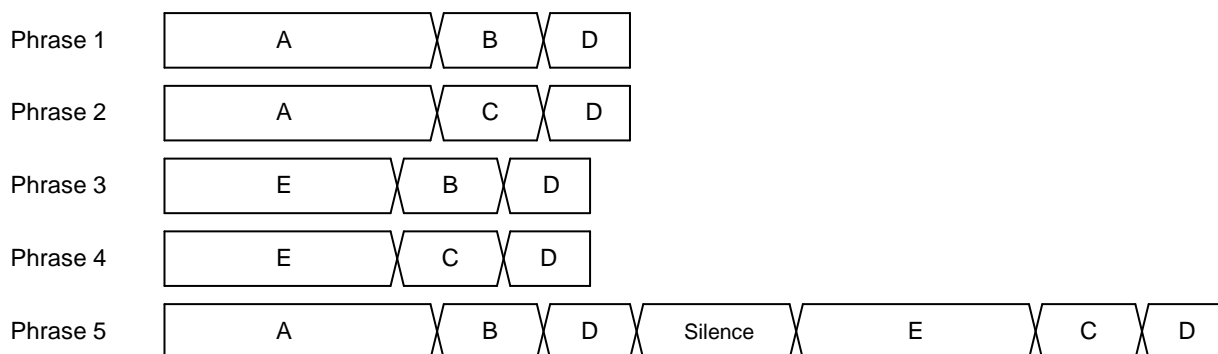

Example 2) Structure of the ROM that contents of example 1 are stored

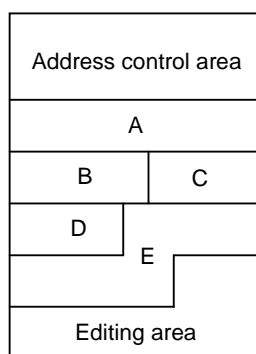

Memory Bank Switching Function

The memory bank switching function enables the the built-in ROM area that is divided into up to four banks to be used. When four banks are used, the maximum number of phrases per bank is 1024 so that up to 4096 phrases can be played back.

Using this function, multiple ROM codes can be grouped into one code.

The settings of SEL1 pin and SEL0 pin determines which memory bank is used. To playback phrases, the number of memory banks must be specified in PUP.

When using a memory bank switching function, data must be divided and saved in the specified areas at ROM data creation.

– When the number of memory banks is 1

SEL1	SEL0	ML22725-XXX ML22765-XXX	ML22724-XXX ML22764-XXX	ML22723-XXX ML22763-XXX
0	0	00000h – 1FFFFFFh	00000h – FFFFFFFh	00000h -7FFFFFFh

– When the number of memory banks is 2

SEL1	SEL0	ML22725-XXX ML22765-XXX	ML22724-XXX ML22764-XXX	ML22723-XXX ML22763-XXX
0	0	00000h – FFFFFFFh	00000h – 7FFFFFFh	00000h – 3FFFFFFh
0	1	100000h – 1FFFFFFh	80000h – FFFFFFFh	40000h – 7FFFFFFh

– When the number of memory banks is 4

SEL1	SEL0	ML22725-XXX ML22765-XXX	ML22724-XXX ML22764-XXX	ML22723-XXX ML22763-XXX
0	0	00000h – 7FFFFFFh	00000h – 3FFFFFFh	00000h – 1FFFFFFh
0	1	80000h – FFFFFFFh	40000h – 7FFFFFFh	20000h – 3FFFFFFh
1	0	100000h – 17FFFFFFh	80000h – BFFFFFFh	40000h – 5FFFFFFh
1	1	180000h – 1FFFFFFh	C0000h – FFFFFFFh	60000h – 7FFFFFFh

The memory (16 Mbits) in the ML22725 is divided as shown below.

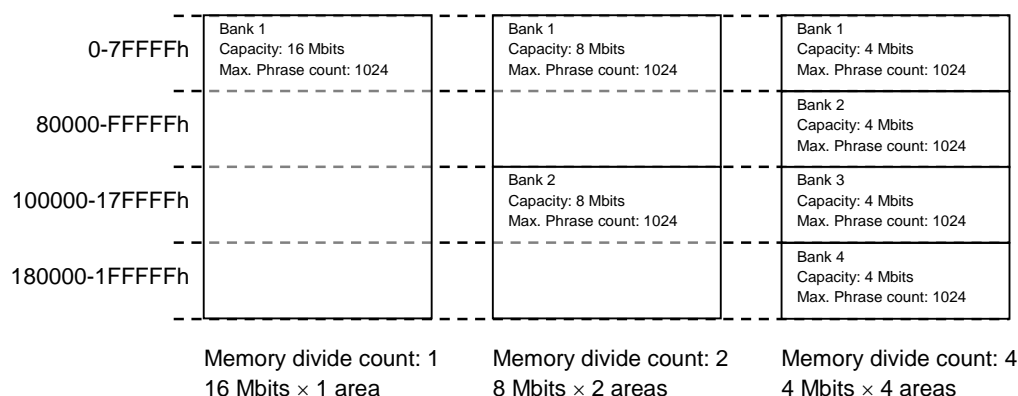

Description of Command Functions

1. PUP command

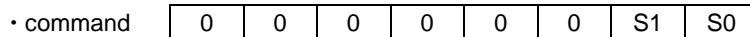

The PUP command is used to shift from the power down state to the command waiting state.

This command is only available at the power down state .

Conditions are as follows to enter the power down state.

- 1) When the power is turned on.
- 2) When the RESETB input is “L” level (: rest input).
- 3) When the CBUSYB pin goes to “H” level after inputting the power down command(:PDWN).

The relationship between S1/S0 and the memory banks is as follows:

S1	S0	
0	0	Overall memory area is used.
0	1	The internal memory is divided into 2 areas. The 2 memory areas are switched with the SEL0 pin.
1	0	The internal memory is divided into 4 areas. The 4 memory areas are switched with the SEL1 and SEL0 pins.
1	1	Prohibited (The operation is the same as above.)

The built-in amplifier is not powered up by this command. It is powered up by the AMODE command.

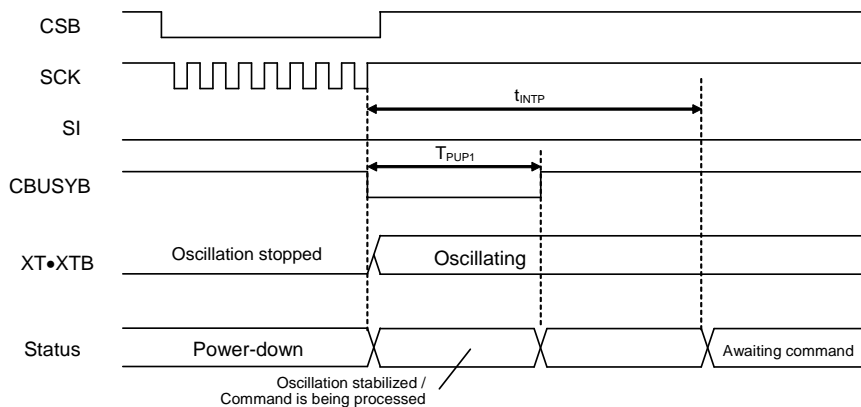

The regulator output starts operating after the PUP command is entered. Any command will be ignored if entered while oscillation is stabilized. However, if a “L” level is input to the RESETB pin, the LSI enters a power down state immediately.

The built-in amplifier is not powered up by the PUP command. It is powered up by the AMODE command.

2. PDWN command

• command

0	0	1	0	0	0	0	0
---	---	---	---	---	---	---	---

The PDWN command is used to shift from the command waiting state (: both NCR and BUSYB are “H” level) to the power down state.

Any setting is initialized by this command, so it is necessary to set again after power up.

This command is not available during playback.

To resume playback after entering power down state, input the AMODE and PLAY commands after input the PUP command.

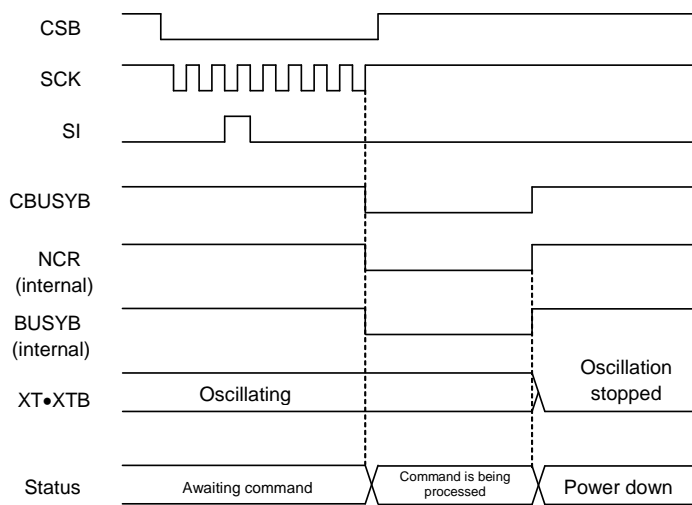

The speaker amplifier stops operation after a lapse of command processing time after the PDWN command is input. At this time, the SPM output of the speaker amplifier goes to “Hi-Z” state to prevent troubles by pop noise .

The status of each output pin is as follows after this command is input or reset pin (:RESETB) is “L” level.

Analog output pin	State
V _{DDL}	GND
V _{DDR}	GND
SG	GND
SPM	HiZ
SPP	GND

3. RDSTAT command

• command

1	0	1	1	0	0	0	0
---	---	---	---	---	---	---	---

The RDSTAT command is used to read the NCR and BUSYB signals that indicate the status of internal operation.

The NCR signal is “L” level while commands are processed, and goes to “H” level at the command waiting state.

The BUSYB signal is “L” level during playback voices.

The command interval time (: t_{INTRD}) is needed to input the next command after reading status using this command.

The following table shows the contents of each bit of data output.

	Output status signal
MSB	—
7SB	—
6SB	—
5SB	BUSYB output
4SB	—
3SB	—
2SB	—
LSB	NCR output

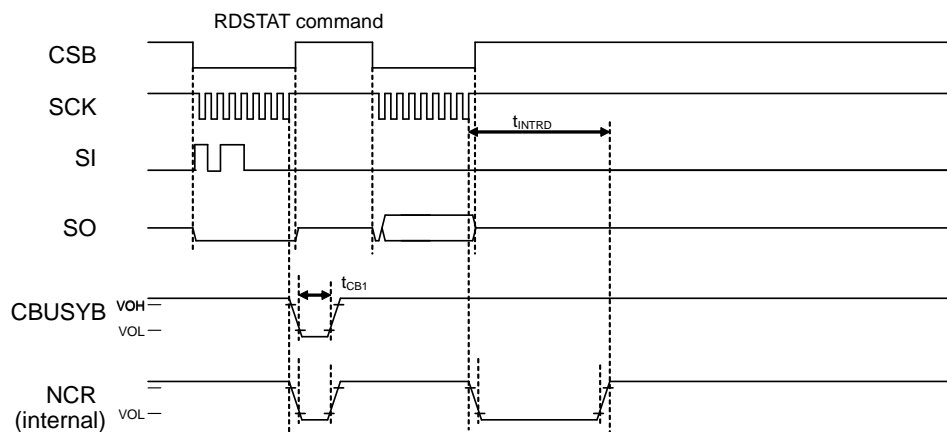

Explanation of NCR/BUSYB is shown in the following figure.

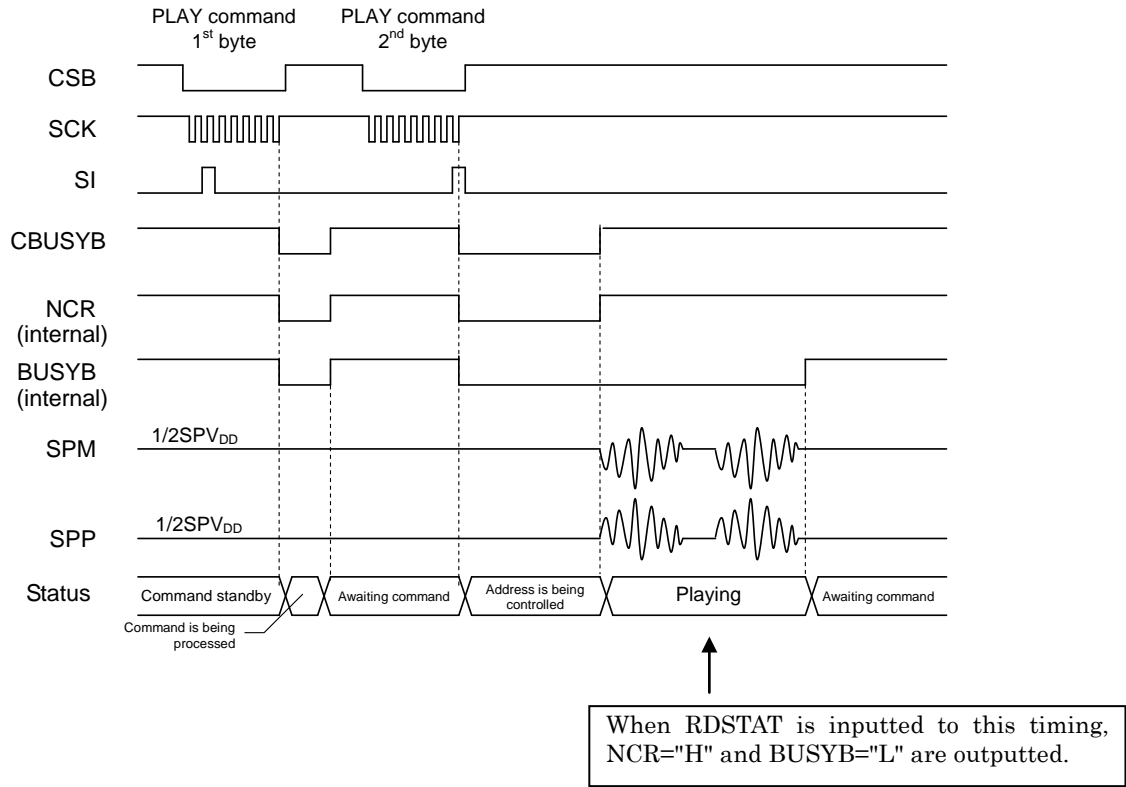

NCR outputs "L" during command processing and address administration, and outputs "H" in other state.
 BUSYB outputs "L" during command processing and reproduction, and outputs "H" in other state.
 NCR/BUSYB at the time of inputting the RDSTAT command is read as the serial output from SO terminal.

4. AMODE command

· command	0	0	0	0	0	1	0	0	1 st byte
	FAD	DAG1	DAG0	AIG1	AIG0	DAEN	SPEN	POP	2 nd byte

The AMODE command uses 2 bytes. This command is used to perform various settings for analog circuitry. This command is not available during power-down state, transition to power-up state, transition to power down state or playback state.

In the case of performing power down using PDWN command during power up of analog circuitry, the setting of power up by AMODE command is retained. Use the AMODE command to perform power down, if need to use different conditions from power up of analog circuitry.

In the case of power up of analog circuitry, input the AMODE command after setting the CVOL command to “00h” (: initial value).

The setting of each bit is shown below.

The setting is initialized by reset release or power up.

The FAD bit specifies whether to perform fade-out processing when the STOP command is input. If this bit is set to “1”, fade-out processing is performed during a period of approx. 3 ms after the STOP command is input. The BUSYB signal goes to “H” level after fade-out processing.

FAD	Fade-out processing
0	Not available (initial value)
1	Available

The DAG1, 0 bits are used to set the gain of the internal DAC signal. The AIG1, 0 bits are used to set the gain of an analog input signal from the AIN pin. They are available only when using the speaker amplifier.

DAG1	DAG0	Volume
0	0	Input OFF
0	1	Input ON (-6 dB)
1	0	Input ON (0 dB) (initial value)
1	1	Prohibited (input ON (0 dB))

AIG1	AIG0	Volume
0	0	Input OFF (initial value)
0	1	Input ON (-6 dB)
1	0	Input ON (0 dB)
1	1	Prohibited (input ON (0 dB))

The DAEN bit controls power-up and power-down of the DAC circuitry.

DAEN	Status of the DAC circuitry
0	Power-down state (initial value)
1	Power-up state

The SPEN bit controls power-up and power-down of the speaker circuitry. When the SPEN bit is “0”, SPP pin is the LINE output.

SPEN	Status of the speaker circuitry
0	Power-down state (initial value)
1	Power-up state

The POP bit sets whether to suppress the “pop” noise of the LINE output.

– In the case of setting the POP bit to “0”

If the DAEN bit is “1”, LINE output rises from the GND level to the SG level during a period of the specified time (t_{PUPA1}). If the DAEN bit is “0”, LINE output falls from the SG level to the GND level during a period of the specified time (t_{PDA1}).

– In the case of setting the PUP bit to “1”

If the DAEN bit is “1”, LINE output rises from the GND level to the SG level during a period of the specified time (t_{PUPA2}). If the DAEN bit is “0”, LINE output falls from the SG level to the GND level during a period of the specified time (t_{PDA2}).

POP	Pop noise suppression
0	Not available (initial value)
1	Available

- When POP bit is “0”, SPEN bit is “0” and DAEN bit goes to “1”

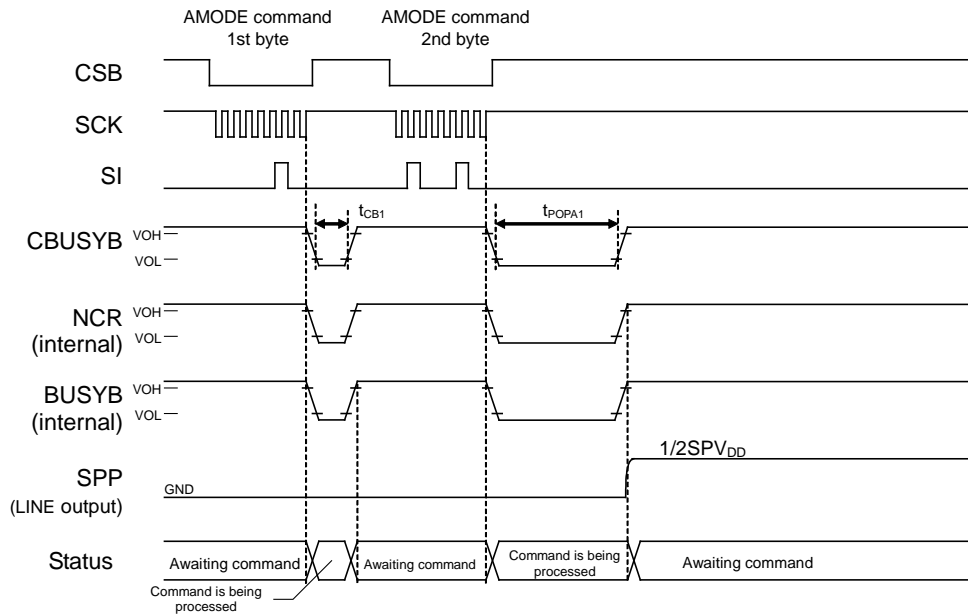

- When POP bit is “1”, SPEN bit is “0” and DAEN bit goes to “1”

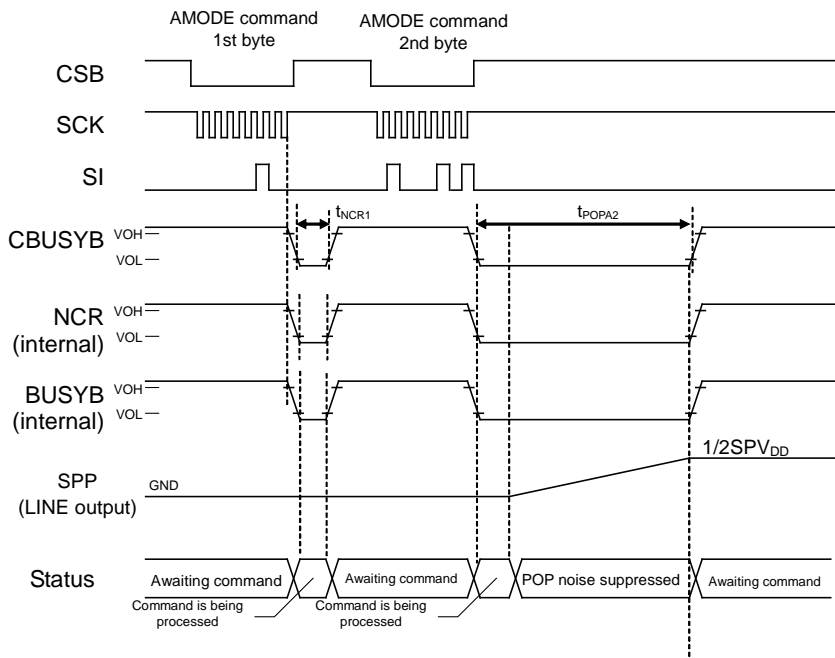

- When SPEN bit goes to “1”

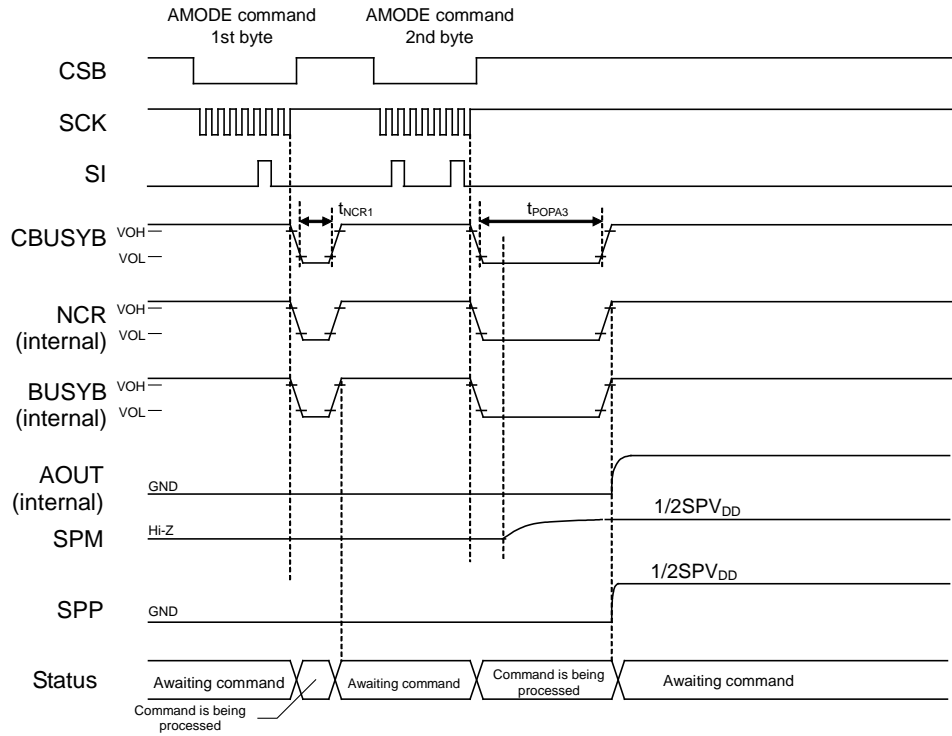

- When POP bit is “0”, SPEN bit is “0” and DAEN bit goes to “0”

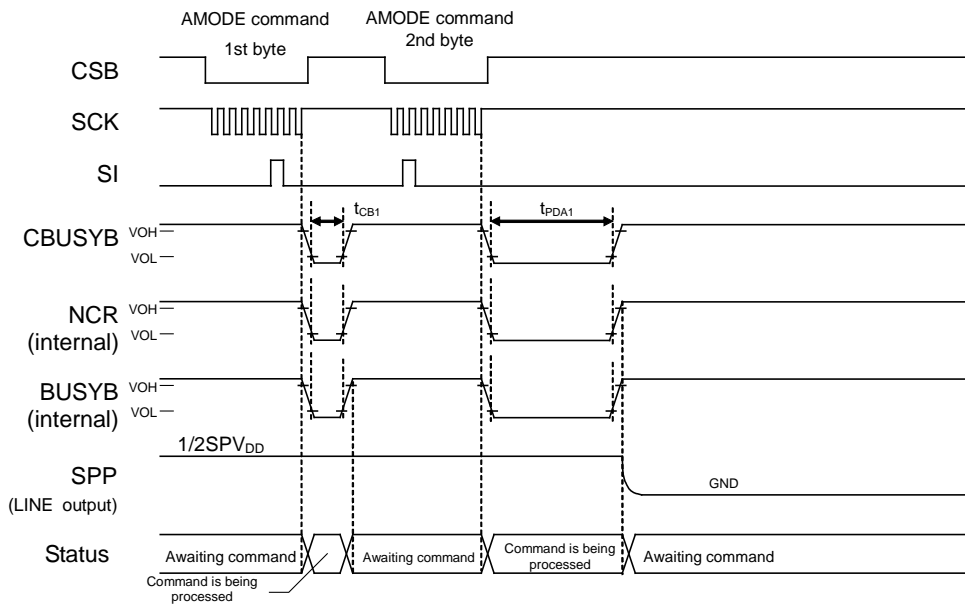

- When POP bit = “1”, DAEN and SPEN bits = “1” → “0” (Applies only when SPEN = “0”)

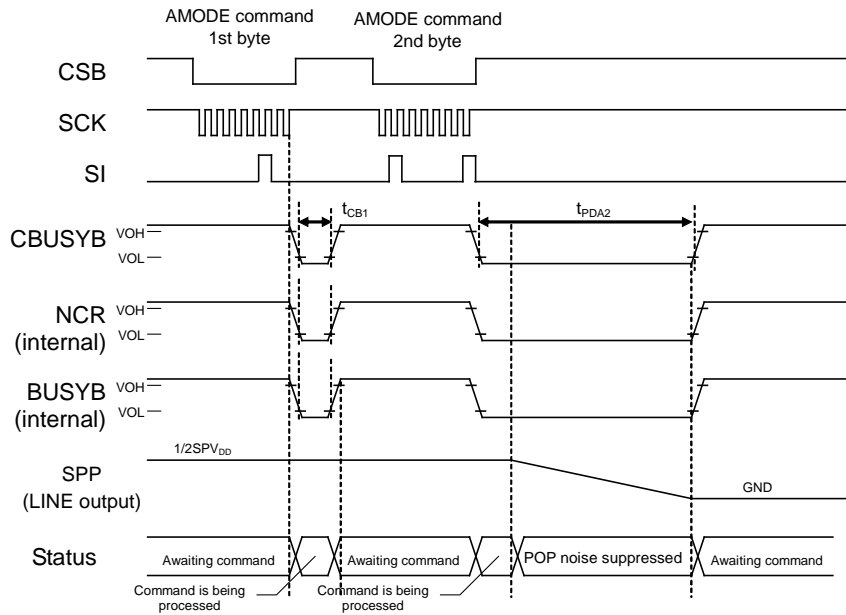

- When SPEN bit goes to “0”

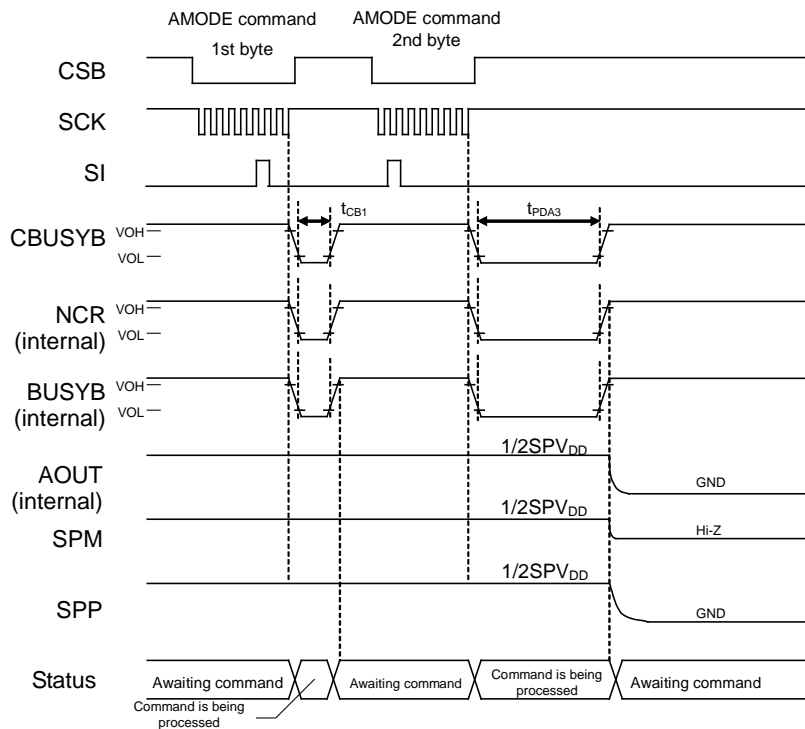

5. PLAY command

· command	0	1	0	0	F9	F8	0	0	1 st byte
	F7	F6	F5	F4	F3	F2	F1	F0	2 nd byte

The PLAY command uses 2 bytes. This command is used to start playback phrase. This command is able to input when the NCR signal is “H” level.

For the phrase to be played back, set the phrase address of voice data in the ROM using the F9 to F0 bits.

The following figure shows the timing of playback phrase (F9 to F0 is 01h).

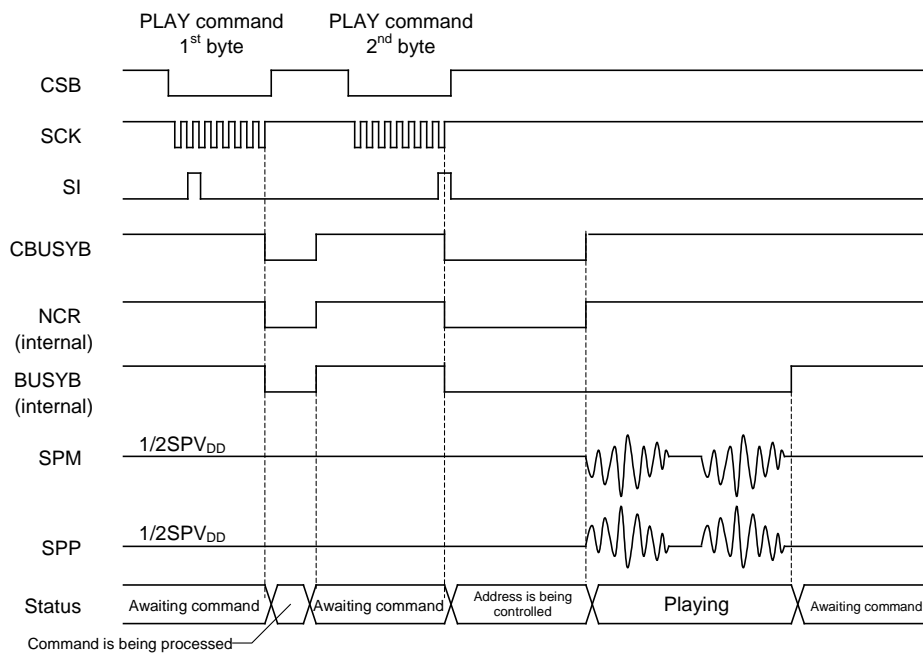

When the 1st byte of the PLAY command is input, the device enters a state awaiting input of the 2nd byte of the PLAY command after a lapse of command processing time. When the 2nd byte of PLAY command is input, the device starts reading the external ROM to get the address information of the phrase to be played back after a lapse of command processing time. Thereafter, playback starts and the playback is performed up to the specified ROM address, then the playback stops automatically.

The NCR signal is “L” level during address control, and goes to “H” level when the address control is completed. Then it is possible to input the PLAY command for the next playback phrase.

The BUSYB signal is “L” level during address control and playback, and goes to “H” level when playback is completed. Then it is possible to know whether the playback is going on by the BUSYB signal.

The PLAY Command Input Timing for Continuous Playback

In the case of continuous playback, input the PLAY command for the next phrase within the command input enable time (: t_{cm}) after NCR goes to “H” level. Then it is possible to start playback the next phrase without any silent interval between phrases.

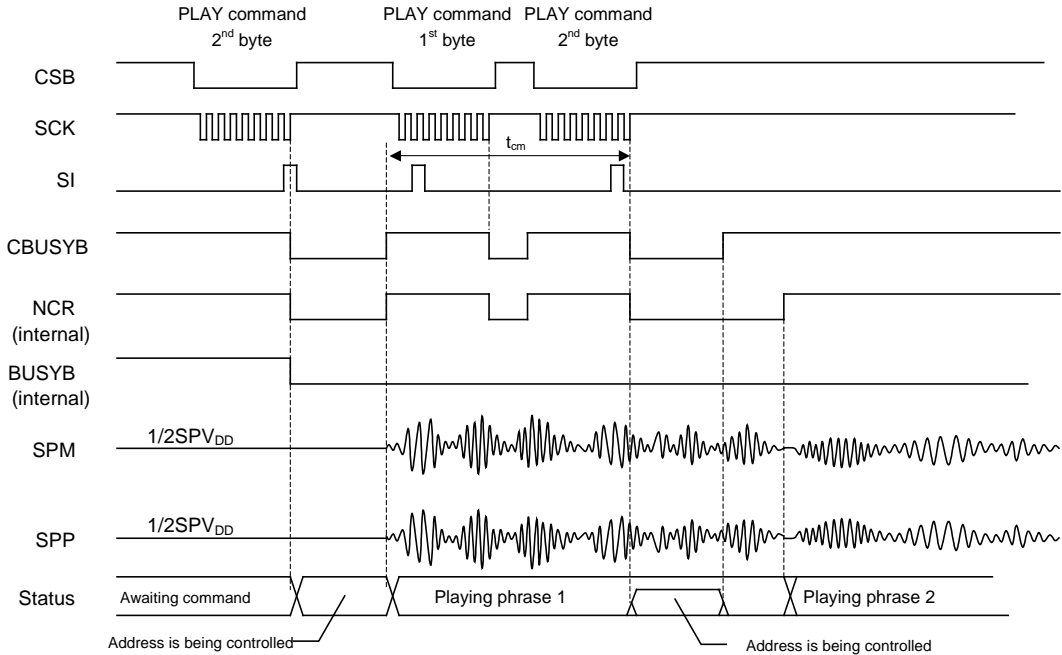

As shown in the diagram above, if continuous playback is carried out, input the PLAY command for the second phrase within 10 ms (t_{cm}) after NCR goes to “H”. This will make it possible to start playing the second phrase immediately after the playback of the first phrase finishes. Phrases can thus be played continuously without inserting silence between phrases.

6. STOP command

• command

0	1	1	0	0	0	0	0
---	---	---	---	---	---	---	---

The STOP command is used to stop playback.

If the playback is stopped, the NCR and BUSYB signals go to “H” level.

Although it is possible to input this command regardless of the status of NCR during playback, a prescribed command interval time (t_{INT}) is needed.

The STOP command is not available during power down, transition to power-up or transition to power-down.

The playback related command (:PLAY, START or MUON) is not available during STOP command processing.

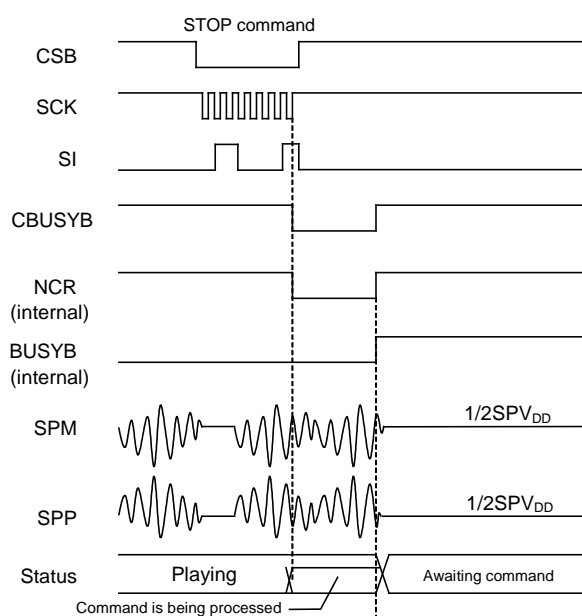

The playback related command (:PLAY, START or MUON), used on after the STOP command, should be input after confirming the completion (: NCR is “H” and BUSYB is “H”) of this command processing by the RDSTAT command, or waiting for 12ms from transition of the CBUSYB to “H” level.

7. FADR command

• command	0	0	1	1	F9	F8	0	0	1 st byte
	F7	F6	F5	F4	F3	F2	F1	F0	2 nd byte

The FADR command uses 2 bytes. This command is used to specify phrase to be played. The phrase to be played back are set by this command.

Playback will be started by START command after the phrase is specified.

For the phrase to be played back, set the phrase address of voice data in the ROM using the F9 to F0 bits.

The setting values of the FADR command are initialized at the power-down.

8. START command

• command

0	1	0	1	0	0	0	0
---	---	---	---	---	---	---	---

The START command is used to start playback a phrase. It is necessary to specify playback phrase using the FADR command before inputting this command. The following figure shows the timing when starting playback.

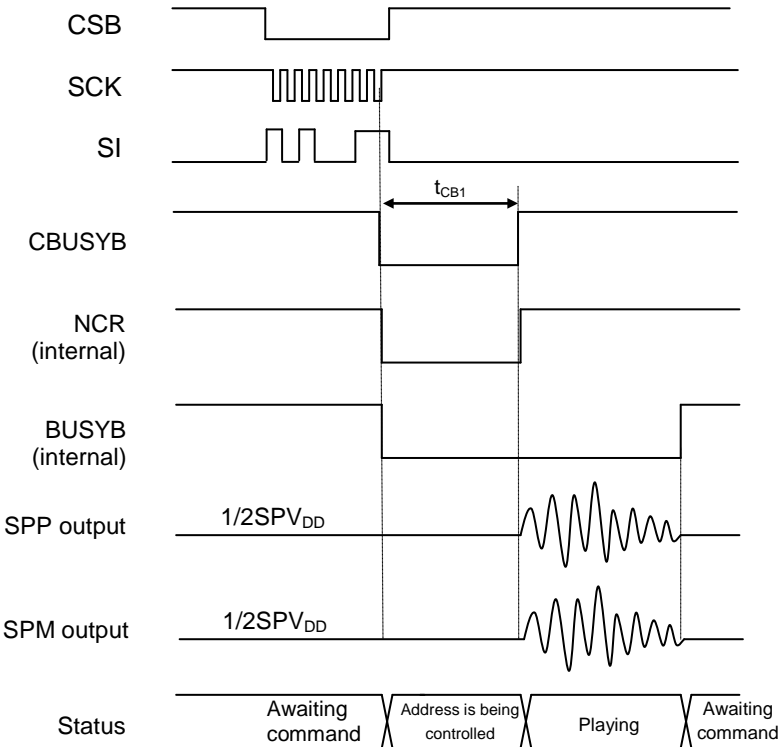

The START Command Input Timing for Continuous Playback

The START command input timing in the case of reproducing the following phrase succeeding the one phrase playback is shown.

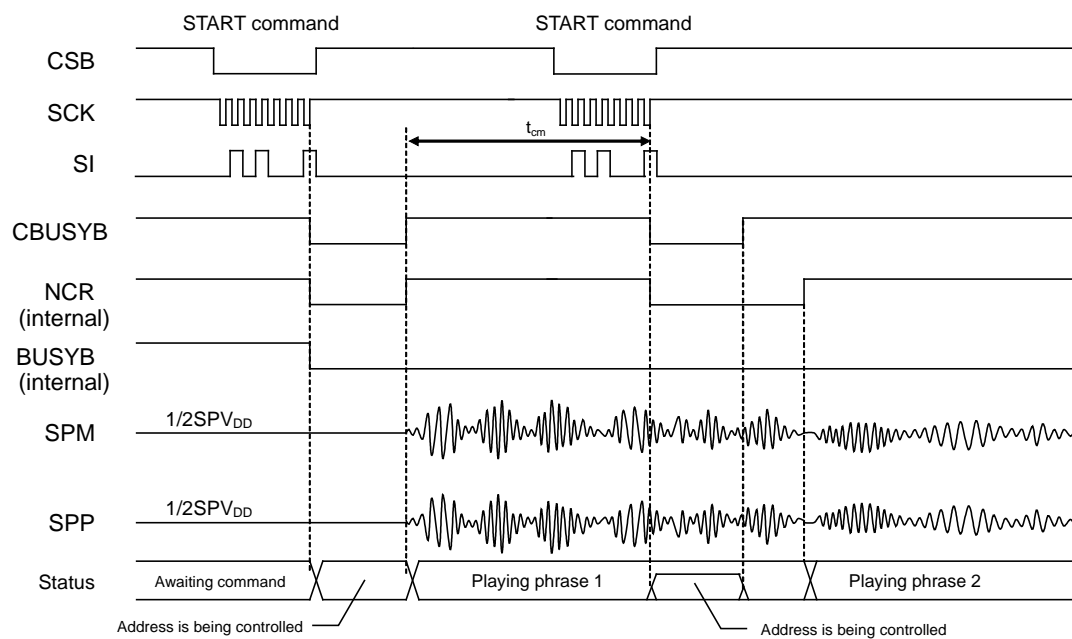

As shown in the diagram above, if continuous playback is carried out, input the START command for the second phrase (t_{cm}) after NCR goes "H". When it cannot, please input the phrase 2 START command after checking that BUSYB became "H"(phrase 1 playback has been finished).

9. MUON command

• command

0	1	1	1	0	0	0	0	1 st byte
M7	M6	M5	M4	M3	M2	M1	M0	2 nd byte

The MUON command uses 2 bytes. This command is used to insert the silence between two playback phrases. This command can be input when the NCR signal is “H” level. Set the silent time value after inputting this command.

The silent time length to be specified by M7 to M0 bits is able to be set by 256 steps at 4 ms interval between 20 ms and 1,024 ms.

The silent time length (t_{mu}) is calculated by equation as below.

The silent time length should be set to 04h or higher (t_{mu} is 20ms or more).

$$T_{mu} = (2^7 \times (M7) + 2^6 \times (M6) + 2^5 \times (M5) + 2^4 \times (M4) + 2^3 \times (M3) + 2^2 \times (M2) + 2^1 \times (M1) + 2^0 \times (M0) + 1) \times 4ms$$

The following figure shows the timing of inserting the silence of 20 ms between the repetitions of phrase (F7 to F0 is 01h).

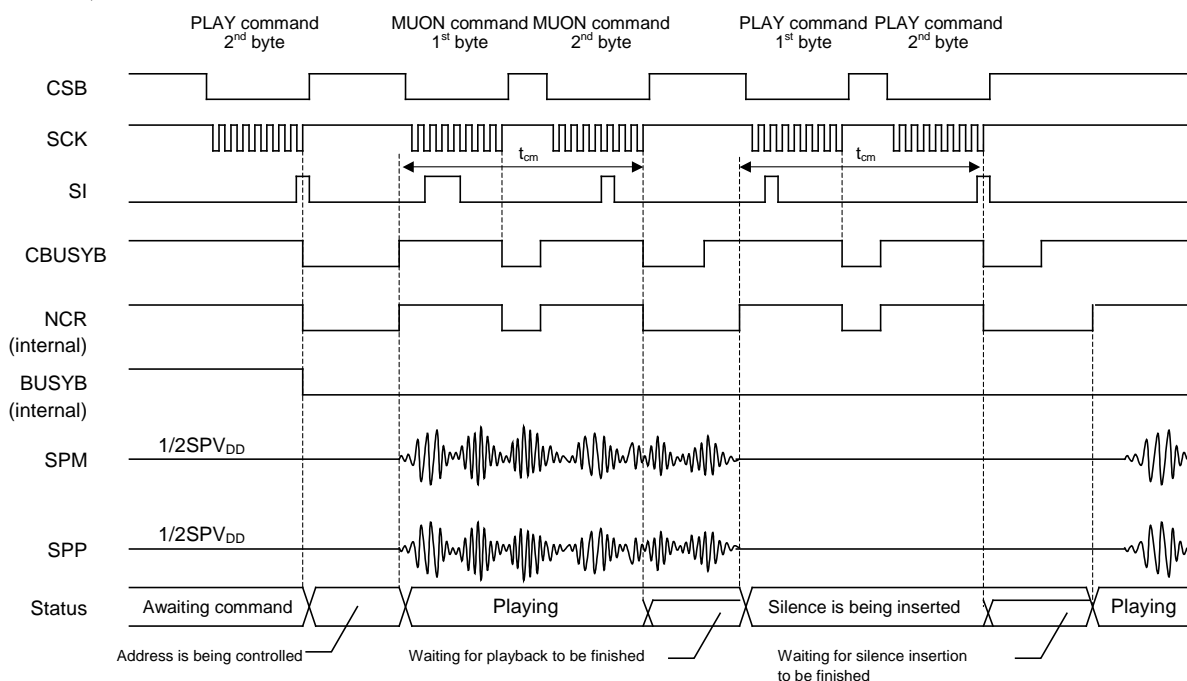

When the playback starts after the PLAY command is input and the address control of phrase-1 is over, the CBUSYB and NCR signals go to “H” level. Input the MUON command after this CBUSYB signal changes to “H” level. After the MUON command input, the NCR signal remains at “L” level until the end of phrase-1 playback. This status is the waiting for the phrase-1 playback to be finished.

When the phrase-1 playback is finished, the silence playback starts and the NCR signal goes to “H” level. Then, input the PLAY command again to playback phrase-1. Then, the NCR signal goes to “L” level again and the device enters a state of the waiting for the end of silence playback.

When the silence playback is finished and then the phrase-1 playback starts, the NCR signal goes to “H” level, and the device enters a status where it is possible to input the next PLAY or MUON command.

The BUSYB signal remains “L” level until the end of a series of playback.

10. SLOOP command

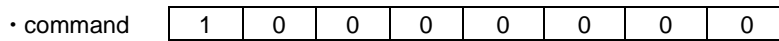

The SLOOP command is used to set the repeat playback mode.

Use the CLOOP command to release repeat playback mode.

Since the SLOOP command is only valid during playback, be sure to input the SLOOP command while the NCR signal is “H” level after the PLAY command is input. The NCR signal is “L” level during repeat playback mode.

Once repeat playback mode is set, the current phrase is repeatedly played until the repeat playback setting is released by the CLOOP command or until playback is stopped by the STOP command. In the case of a phrase that was edited by the edit function, the edited phrase is repeatedly played.

The repeat playback mode is released if playback is stopped by the STOP command, therefore input the SLOOP command again if need to repeat playback again.

The following figure shows the SLOOP command input timing.

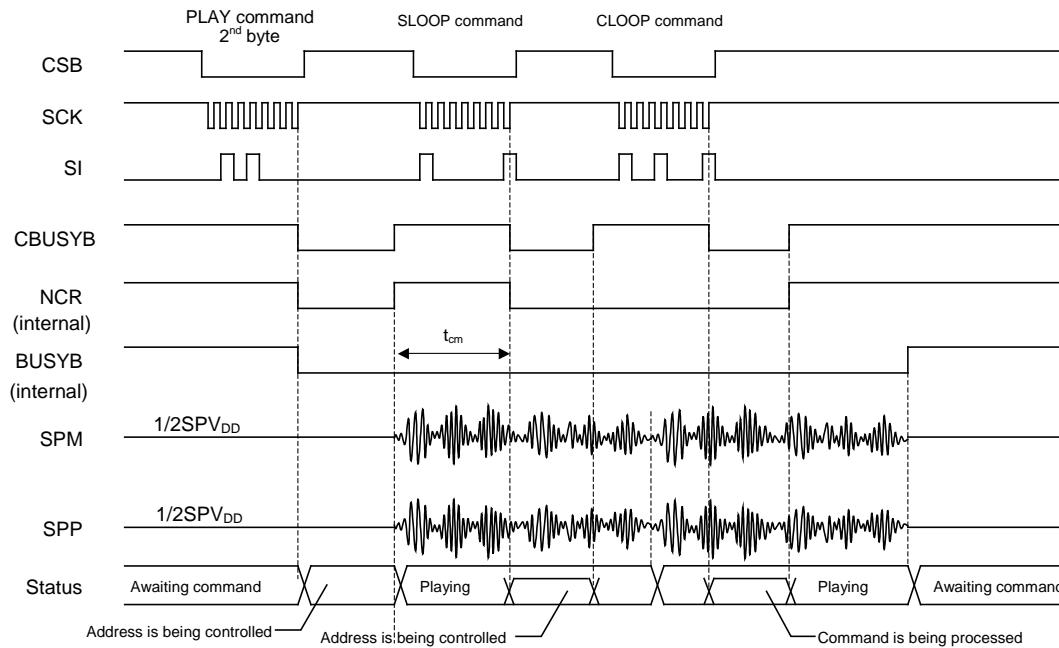

Effective Range of SLOOP Command Input

After the PLAY command is input, input the SLOOP command within the command input enable time (: t_{cm}) after NCR goes to “H”. Then, the SLOOP command is available to repeat playback.

11. CLOOP command

• command

1	0	0	1	0	0	0	0
---	---	---	---	---	---	---	---

The CLOOP command is used to release the repeat playback mode.

When the repeat playback mode is released, the NCR signal goes to “H” level.

It is possible to input this command regardless of the NCR signal status during playback, but a prescribed command interval time (t_{INT}) is needed.

12. CVOL command

• command	1	0	1	0	0	0	0	0	1 st byte
	0	0	0	CV4	CV3	CV2	CV1	CV0	2 nd byte

The CVOL command uses 2 bytes. This command is used to adjust the playback volume. It is possible to input this command regardless of the NCR status. This command is not available during power down, transition to the power-up state or transition to the power-down state.

This command can adjust volume by 32-levels as shown in the table below. The initial value is set to 0 dB after the reset is released. Also, the setting of this command is initialized after the reset is released or during power-up.

CV4-0	Volume	CV4-0	Volume
00	0dB (initial value)	10	-6.31
01	-0.28	11	-6.90
02	-0.58	12	-7.55
03	-0.88	13	-8.24
04	-1.20	14	-9.00
05	-1.53	15	-9.83
06	-1.87	16	-10.74
07	-2.22	17	-11.77
08	-2.59	18	-12.93
09	-2.98	19	-14.26
0A	-3.38	1A	-15.85
0B	-3.81	1B	-17.79
0C	-4.25	1C	-20.28
0D	-4.72	1D	-23.81
0E	-5.22	1E	-29.83
0F	-5.74	1F	OFF

13. AVOL command

• command	0	0	0	0	1	0	0	0	1 st byte
	0	0	AV5	AV4	AV3	AV2	AV1	AV0	2 nd byte

The AVOL command uses 2 bytes. This command is used to adjust the playback volume. It is possible to input this command regardless of the NCR status. This command is not available during power down state, transition to power-up state or transition to power-down state.

This command can adjust volume by 50-levels as shown in the table below. The initial value is set to -4.0 dB after the reset is released. When the STOP command is input, the value set by the AVOL command is retained. When powered down, the value set by the AVOL command is initialized.

AV5-0	Volume (dB)	AV5-0	Volume (dB)	AV5-0	Volume (dB)	AV5-0	Volume (dB)
3F	+12.0	2F	+4.0	1F	-8.0	0F	-34.0
3E	+11.5	2E	+3.5	1E	-9.0	0E	OFF
3D	+11.0	2D	+3.0	1D	-10.0	0D	OFF
3C	+10.5	2C	+2.5	1C	-11.0	0C	OFF
3B	+10.0	2B	+2.0	1B	-12.0	0B	OFF
3A	+9.5	2A	+1.5	1A	-13.0	0A	OFF
39	+9.0	29	+1.0	19	-14.0	09	OFF
38	+8.5	28	+0.5	18	-16.0	08	OFF
37	+8.0	27	+0.0	17	-18.0	07	OFF
36	+7.5	26	-1.0	16	-20.0	06	OFF
35	+7.0	25	-2.0	15	-22.0	05	OFF
34	+6.5	24	-3.0	14	-24.0	04	OFF
33	+6.0	23	-4.0 (initial value)	13	-26.0	03	OFF
32	+5.5	22	-5.0	12	-28.0	02	OFF
31	+5.0	21	-6.0	11	-30.0	01	OFF
30	+4.5	20	-7.0	10	-32.0	00	OFF

To know the volume controls more

Three commands (: CVOL, AVOL and AMODE) can control volume. CVOL sets volume of voice data. AVOL sets volume of signal after D/A converting. And AMODE sets input gain of amplifier.

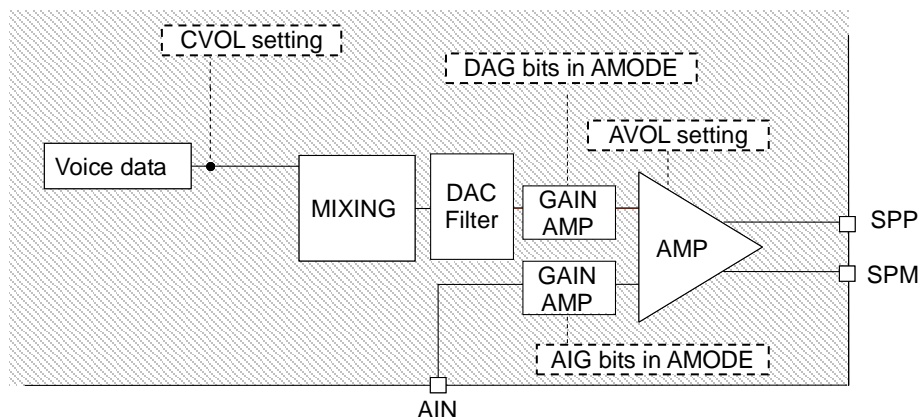

14. VPITCH command

• command	1	1	1	0	0	0	0	0	1 st byte
	PI7	PI6	PI5	PI4	PI3	PI2	PI1	PI0	2 nd byte

The VPITCH command is a 2-byte instruction command. This command reproduces the speech data with the pitch that is specified in the 2nd byte without changing the speed. This command converts the pitch for the original sound. The pitch conversion function (PI7-PI0) can convert the pitch of the original sounds up to ±20% (40 levels) in 1% steps. See below for the pitch conversion data.

After reset release or at power-down, the command setting values are initialized.

PI7	PI6	PI5	PI4	PI3	PI2	PI1	PI0	Change in pitch
0	1	1	1	1	1	1	1	0.2
0	1	1	1	1	1	1	0	0.2
:								:
0	0	0	1	0	0	0	1	0.2
0	0	0	1	0	0	0	0	0.2
0	0	0	0	1	1	1	1	0.1875
0	0	0	0	1	1	1	0	0.175
0	0	0	0	1	1	0	1	0.1625
0	0	0	0	1	1	0	0	0.15
:								:
0	0	0	0	0	1	0	0	0.05
0	0	0	0	0	0	1	1	0.0375
0	0	0	0	0	0	1	0	0.025
0	0	0	0	0	0	0	1	0.0125
0	0	0	0	0	0	0	0	0 (initial value)
1	1	1	1	1	1	1	1	-0.0125
1	1	1	1	1	1	1	0	-0.025
1	1	1	1	1	1	0	1	-0.0375
1	1	1	1	1	1	0	0	-0.05
:								:
1	1	1	1	0	1	0	0	-0.15
1	1	1	1	0	0	1	1	-0.1625
1	1	1	1	0	0	1	0	-0.175
1	1	1	1	0	0	0	1	-0.1875
1	1	1	1	0	0	0	0	-0.2
1	1	1	0	1	1	1	1	-0.2
:								:
1	0	0	0	0	0	0	1	-0.2
1	0	0	0	0	0	0	0	-0.2

15. VSPD command

• command	1	1	0	1	0	0	0	0	1 st byte
	SD7	SD6	SD5	SD4	SD3	SD2	SD1	SD0	2 nd byte

The VSPD command is a 2-byte instruction command. This command reproduces the speech data with the speed that is specified in the 2nd byte without changing the pitch. For the playback speed (SD7-SD0), 150 steps can be set from 0.5 times to 2.0 times at time-step increments of 0.01.

See below for the playback speed.

After reset release or at power-down, the command setting values are initialized.

SD7	SD6	SD5	SD4	SD3	SD2	SD1	SD0	Playback speed (magnification)
0	1	1	1	1	1	1	1	2.00
0	1	1	1	1	1	1	0	2.00
:								:
0	1	1	0	0	1	0	1	2.00
0	1	1	0	0	1	0	0	2.00
0	1	1	0	0	0	1	1	1.99
0	1	1	0	0	0	1	0	1.98
0	1	1	0	0	0	0	1	1.97
:								:
0	0	0	0	0	0	1	1	1.03
0	0	0	0	0	0	1	0	1.02
0	0	0	0	0	0	0	1	1.01
0	0	0	0	0	0	0	0	1.00 (initial value)
1	1	1	1	1	1	1	1	0.99
1	1	1	1	1	1	1	0	0.98
1	1	1	1	1	1	0	1	0.97
:								:
1	1	0	1	0	0	0	1	0.53
1	1	0	1	0	0	0	0	0.52
1	1	0	0	1	1	1	1	0.51
1	1	0	0	1	1	1	0	0.50
1	1	0	0	1	1	0	1	0.50
:								:
1	0	0	0	0	0	0	1	0.50
1	0	0	0	0	0	0	0	0.50

Command Flow Charts

1-Byte Command Input Flow (applied to the PUP, PDWN, STOP, START, SLOOP, and CLOOP commands)

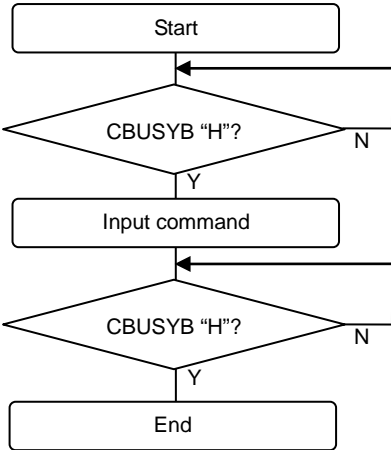

2-Byte Command Input Flow (applied to the AMODE, PLAY, FADR, MUON, CVOL, AVOL, VPITCH, and VSPD commands)

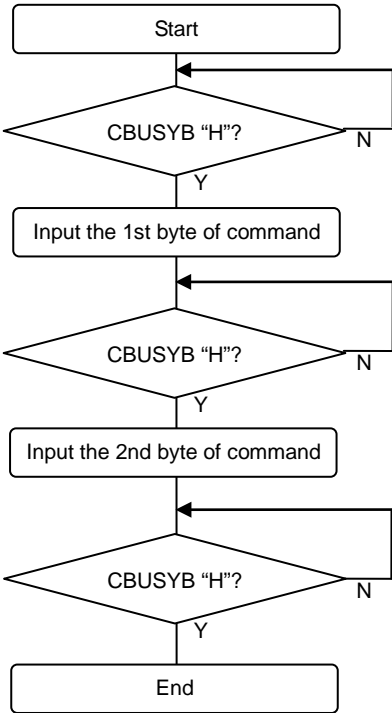

Status Read Flow

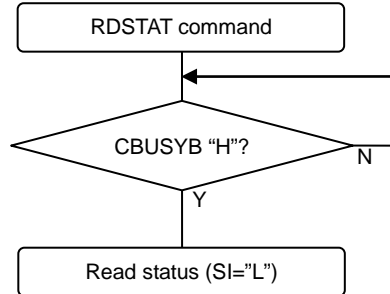

Power-On Flow

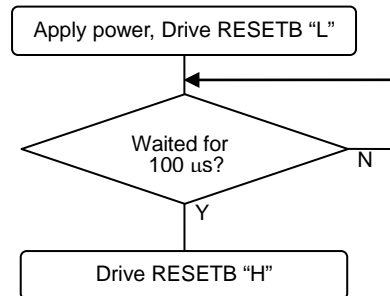

Example of Power-Up Flow

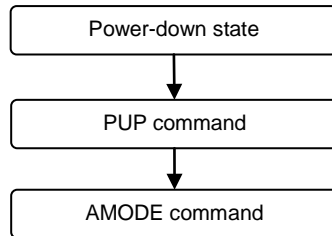

Example of Playback Start Flow

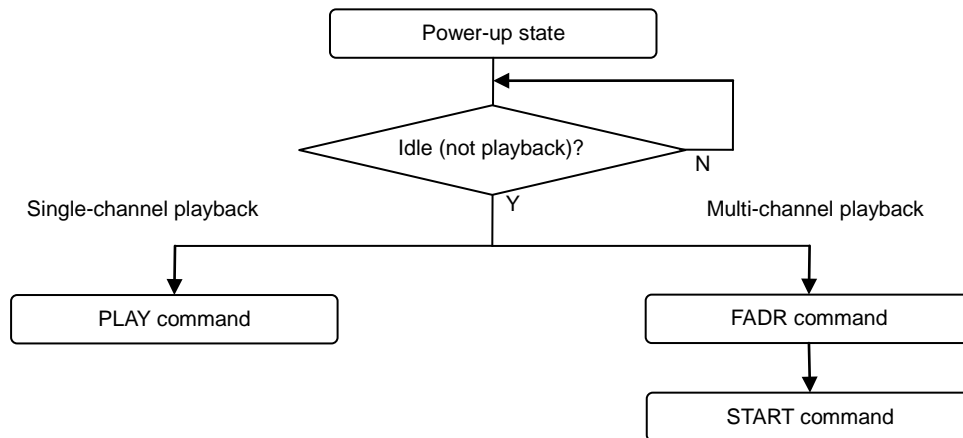

Example of Playback Stop Flow

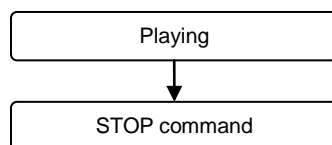

Continuous Playback Start Flow

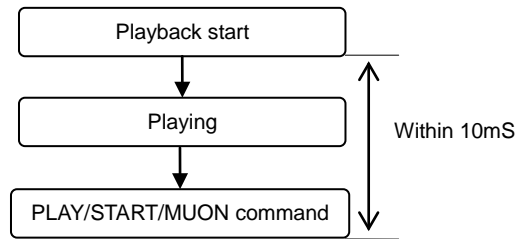

Loop Start Flow

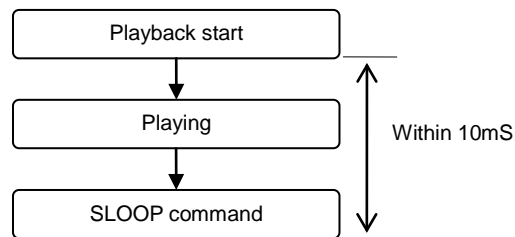

Loop Stop Flow

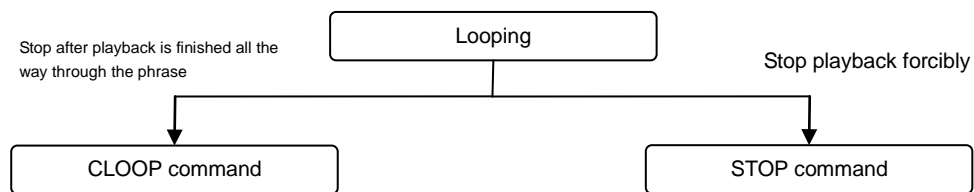

Power-Down Flow

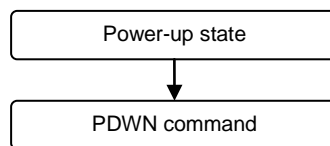

Detailed Flow of “Power-Up ⇒ Playback ⇒ Power-Down”

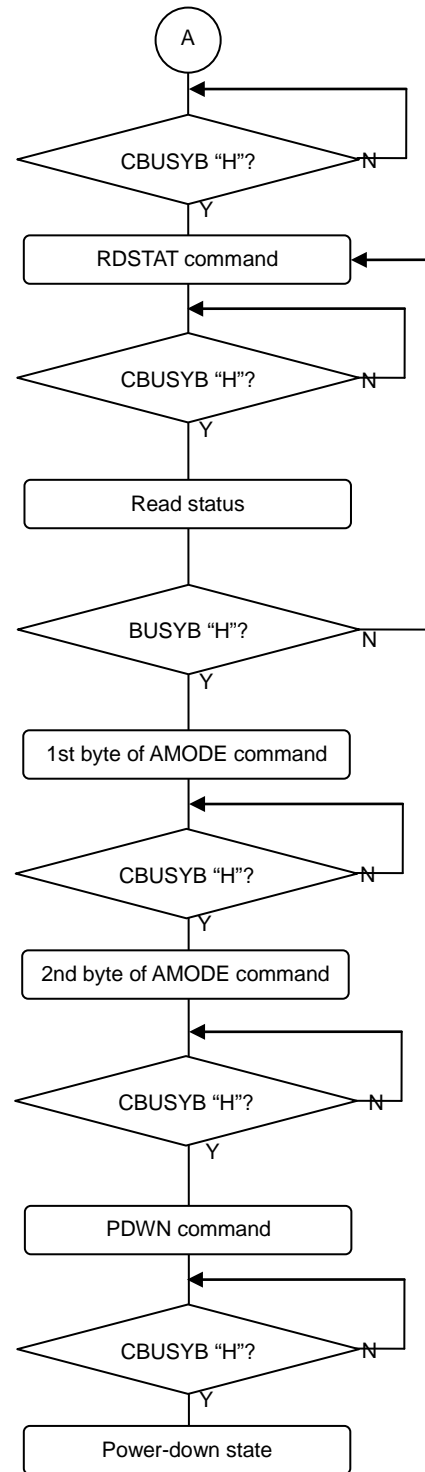
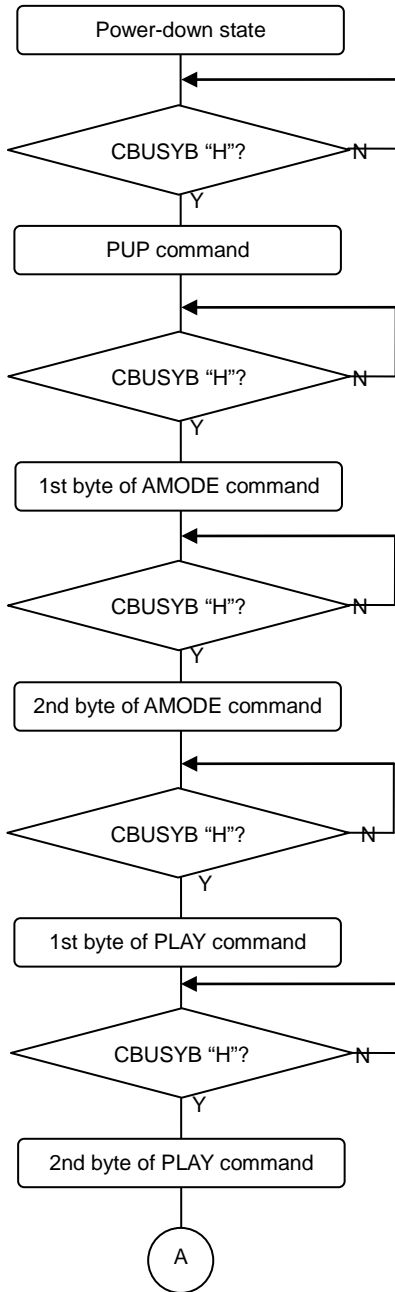

RECOMMENDATION FOR SPEECH SPEED CONVERSION AND PITCH CONVERSION FUNCTION

If user want to use speed and pitch conversion function with keeping speech quality, it's better to use that function on below conditions.

- sampling frequency : 12.8 / 16.0 / 21.3 / 24.0 / 32.0 kHz
- speed conversion : 0.80 to 2.00 times
- pitch conversion : -10 to +10 %

Then these functions work for speech data only. Not work for melody or natural sound.

TERMINATION OF THE SG PIN

The SG pin is the signal ground for the built-in speaker amplifier. Connect a capacitor between this pin and the analog ground (: DGND) pin to prevent the trouble caused by noises.

Recommended capacitance value is shown below. However, it is important to evaluate and decide using the own board.

Also, start playback after each output voltage is stabilized.

Pin	Recommended capacitance value	Remarks
SG	0.1 μ F \pm 20%	The time to stabilize voltage of the speaker outputs (:SPM and SPP) is longer, if use the larger capacitance.

TERMINATION OF THE V_{DDL} AND V_{DDR} PINS

The V_{DDL} pin is the regulator output that is power supply for the internal logic circuitry. Connect a capacitor between this pin and the ground (: DGND) pin to prevent the trouble caused by noises and to hold power supply voltage steady.

The recommended capacitance value is shown below. However, it is important to evaluate and decide using the own board.

Also, start the next operation after each output voltage is stabilized.

Pin	Recommended capacitance value	Remarks
V _{DDL} , V _{DDR}	10 μ F \pm 20%	The time to stabilize voltage of each output is longer, if use the larger capacitance.

POWER SUPPLY WIRING

The power supplies of this LSI are divided into the following two:

- Power supply for logic circuitry (: DV_{DD})
- Power supply for speaker amplifier (: SPV_{DD})

As shown in the figure below, supply DV_{DD} and SPV_{DD} from the same power supply, and separate them into analog and logic power supplies in the wiring.

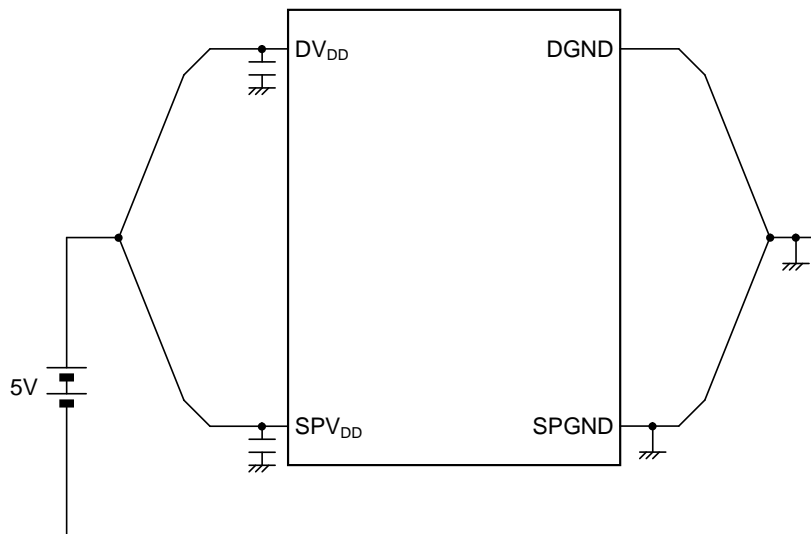

RECOMMENDED CERAMIC RESONATOR

Recommended ceramic resonators for oscillation and conditions are shown below for reference.

KYOCERA Corporation

Freq [Hz]	Type	Optimal load capacity					
		C1 [pF]	C2 [pF]	Rf [Ohm]	Rd [Ohm]	Supply voltage Range [V]	Operating Temperature Range [°C]
4.096M	PBRC4.096MR50X000	15(built-in)		---	--	2.7 to3.3 4.5 to5.5	-40 to +85

Note: C1 and C2 are capacitors built-in resonator.

Circuit diagram

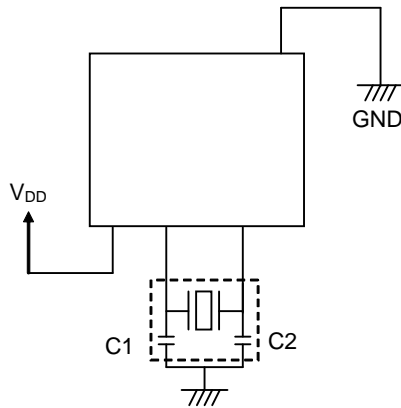

TDK Corporation

Freq [Hz]	Type	Conditions					
		C1 [pF]	C2 [pF]	Rf [Ohm]	C1 [pF]	Supply voltage Range [V]	Operating Temperature Range [°C]
4.000M	FCR4.0MXC5	30 (built-in)		---	---	2.7 to3.6	-40 to +85
	FCR4.0MXC5					4.5 to5.5	
4.096M	FCR4.09MXC5	30 (built-in)		---	---	2.7 to3.6	-40 to +85
	FCR4.09MXC5					4.5 to5.5	

Circuit diagram

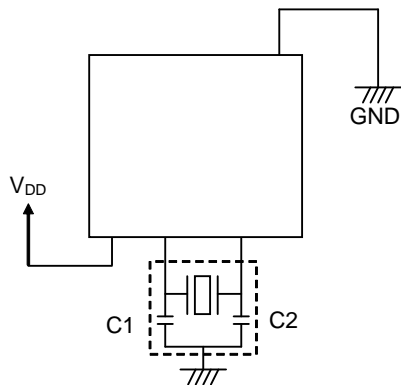

MURATA Corporation

Freq [Hz]	Type		Optimal load capacity					Operating Temperature Range [°C]
			C1 [pF]	C2 [pF]	Rf [Ohm]	Rd [Ohm]	Supply voltage Range [V]	
4.000M	SMD	CSTCR4M00G55-R0	39 (Built-in)		---	0	-40 to +85*	
	Leaded	CSTLS4M00G56-B0	47 (Built-in)					
	SMD	CSTCR4M00G55-R0	39 (Built-in)					
	Leaded	CSTLS4M00G56-B0	47 (Built-in)					
4.096M	SMD	CSTCR4M09G55-R0	39 (Built-in)		---	0	-40 to +85*	
	Leaded	CSTLS4M09G56-B0	47 (Built-in)					
	SMD	CSTCR4M09G55-R0	39 (Built-in)					
	Leaded	CSTLS 4M09G56-B0	47 (Built-in)					

Note: C1 and C2 are capacitors built-in resonator.

Circuit diagram

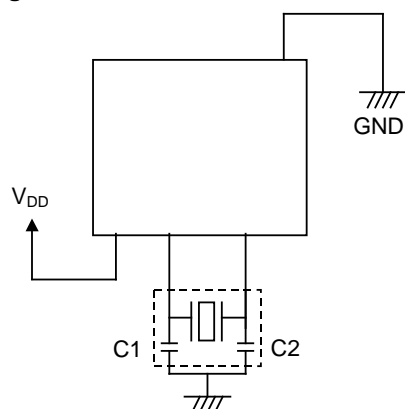

APPLICATION CIRCUIT

ML2272X: $DV_{DD}=SPV_{DD}=5V$

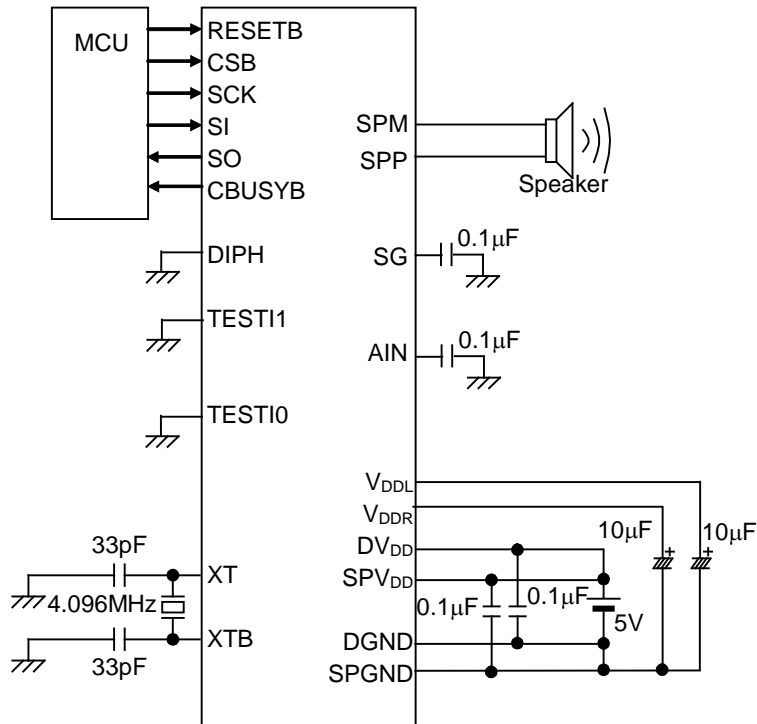

ML2272X: $DV_{DD}=SPV_{DD}=3V$

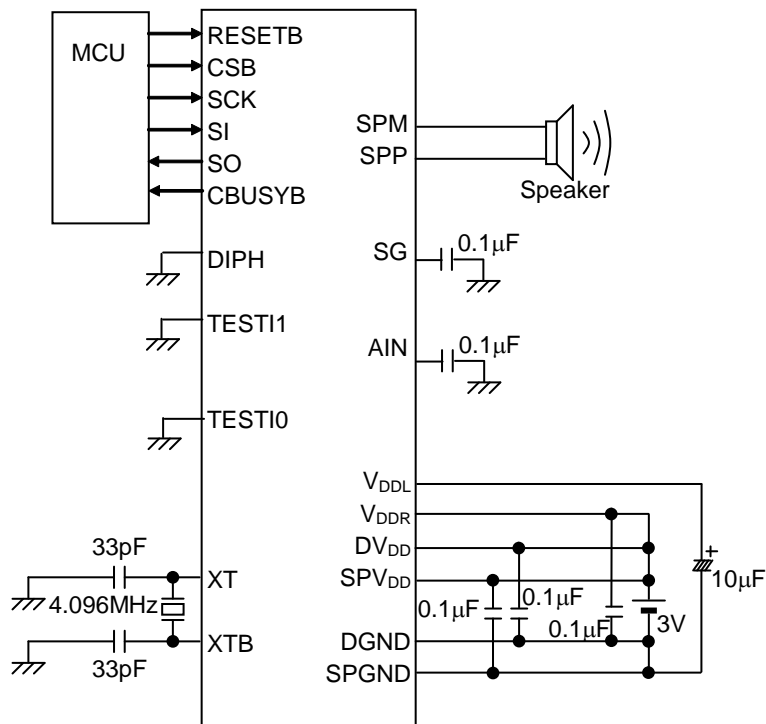

ML2276X: $DV_{DD}=SPV_{DD}=5V$

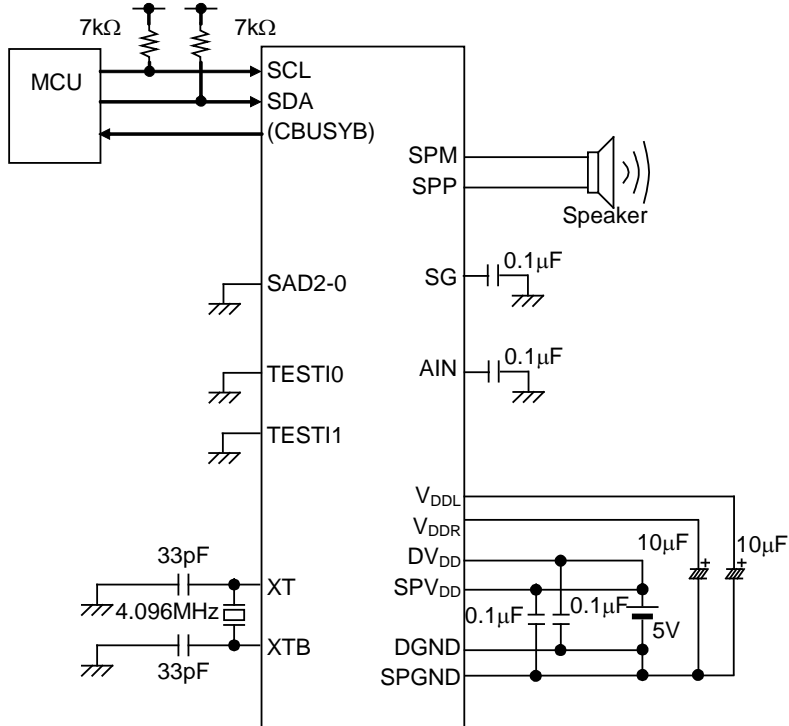

ML2276X: $DV_{DD}=SPV_{DD}=3V$

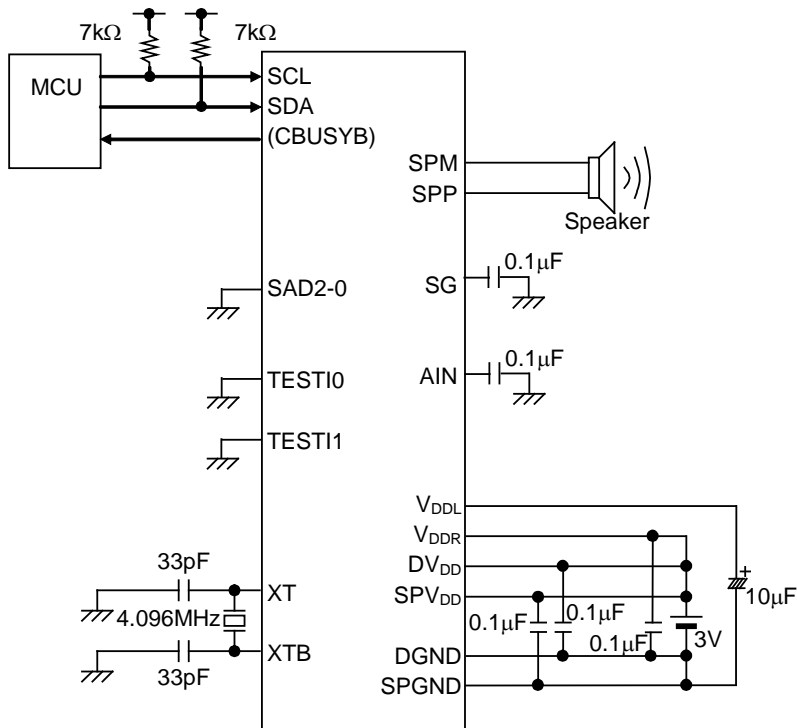

PACKAGE DIMENSIONS

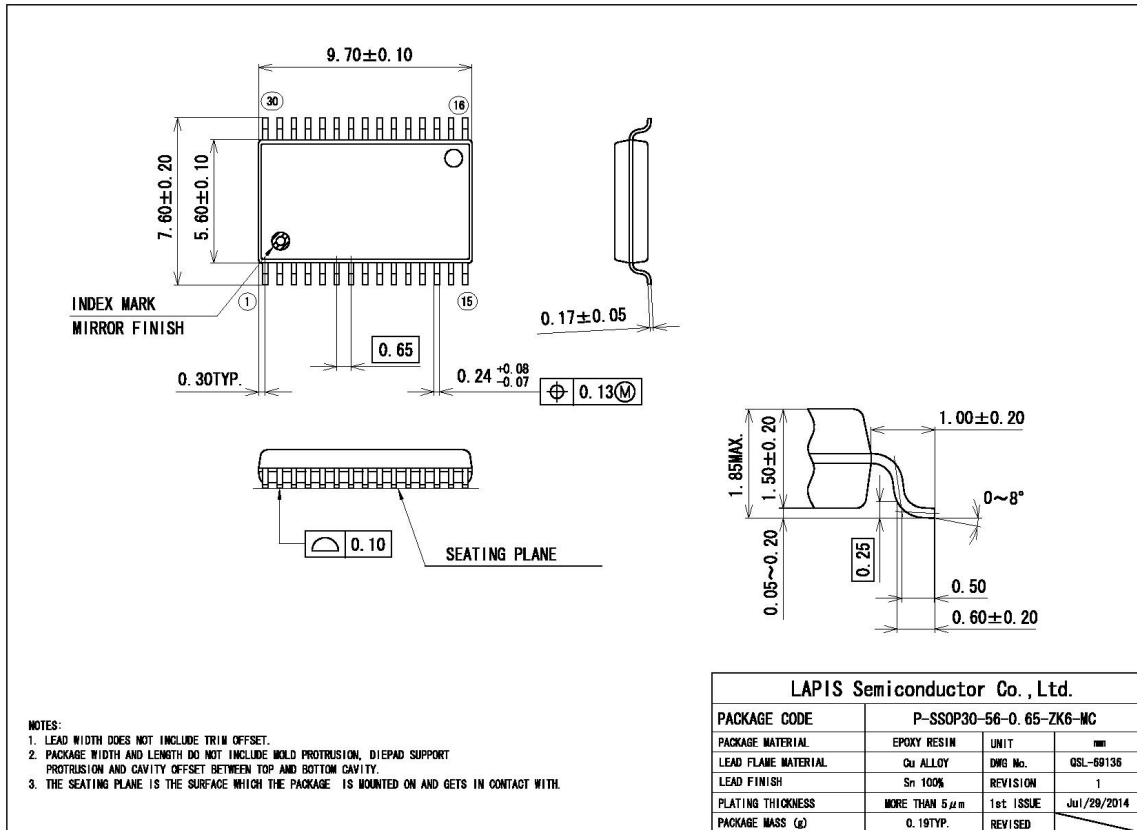

Notes for Mounting the Surface Mount Type Package:

The surface mount type packages are very susceptible to heat in reflow mounting and humidity absorbed in storage. Therefore, before you perform reflow mounting, contact ROHM's responsible sales person for the product name, package name, pin number, package code and desired mounting conditions (reflow method, temperature and times).

REVISION HISTORY

Document No.	Date	Page		Description
		Previous Edition	Current Edition	
PEDL2272XFULL-01	Dec. 17, 2007	–	–	Preliminary edition 1
FEDL2272XFULL-01	Apr. 18, 2008	–	–	Final edition 1
FEDL2272XFULL-02	May. 29, 2008	–	–	Final edition 2
FEDL2272XFULL-03	Mar. 25, 2009	5,6	5,6	Common terminal explanation attribute change (TESTI1,SPP,SPM)
		11	11	Max value change within the range of LINE output voltage
		12	12	Min, Typ, and Max value change of CBUSYB (“L” level output time)
		25,34,35,36,37	24,33,34,35,36	Bit name of AMODE command (PUP->POP)
		53,54	53,54	Modify application circuit
		45	45	Correct value for AVOL
FEDL2272XFULL-04	Aug. 25, 2011	44	44	Modify AVOL table.
FEDL2272XFULL-05	Aug. 30, 2011	24-47	24-47	Delete the explanation about “channel”.
FEDL227XX-06	Oct. 16, 2013	13	13	Modify tDOD1. (SCK rise edge -> SCK fall edge)
FEDL227XX-07	Oct. 25, 2017	1	1	Package is changed.
		2	2	Add Playback method.
		12	12	t _{POPA3} and t _{PD3} is added to CBUSYB “L” level output time in AC Characteristics(Common to All Products). t _{POPA2} is modified to CBUSYB “L” level output time in AC Characteristics(Common to All Products).
		14	14	Time chart of t _{PUP1} is modified.
		15	15	Time chart of t _{PD1} is modified.
		16	16	Explanation of the playback start timing by the PLAY command is added.
		16	16	Explanation of the playback stop timing is added.

Document No.	Date	Page		Description
		Previous Edition	Current Edition	
		17	17	Explanation of the continuous playback timing by the PLAY command is added.
		-	17	"Continuous Playback Timing by the START command" is added.
		17	18	Explanation of the silence Insertion timing by the MUON command is modified.
		18	18	"Repeat Playback Set/Release Timing by the SLOOP and CLOOP Commands" is added.
		18	19	Explanation of the timing of volume change by the CVOL command is modified.
		-	19	"Timing of Volume Change by the AVOL Command" is added.
		-	20-26	"TIMING DIAGRAMS (I2C INTERFACE (ML2276X))" is added.
		27	35	Add Silence step.
		-	40	Explanation of NCR/BUSYB is added to the time chart of RDSTAT.
		34,35	43-45	Time chart of t_{POPA3} and t_{PDA3} is added. Time chart of t_{POPA1} , t_{POPA2} , t_{PDA1} and t_{PDA2} is modified.
		-	52	"The START Command Input Timing for Continuous Playback" is added.
		-	59-62	Add Command Flow Charts.
		55	70	Change of the package.

Notes

- 1) The information contained herein is subject to change without notice.
- 2) Although LAPIS Semiconductor is continuously working to improve product reliability and quality, semiconductors can break down and malfunction due to various factors. Therefore, in order to prevent personal injury or fire arising from failure, please take safety measures such as complying with the derating characteristics, implementing redundant and fire prevention designs, and utilizing backups and fail-safe procedures. LAPIS Semiconductor shall have no responsibility for any damages arising out of the use of our Products beyond the rating specified by LAPIS Semiconductor.
- 3) Examples of application circuits, circuit constants and any other information contained herein are provided only to illustrate the standard usage and operations of the Products. The peripheral conditions must be taken into account when designing circuits for mass production.
- 4) The technical information specified herein is intended only to show the typical functions of the Products and examples of application circuits for the Products. No license, expressly or implied, is granted hereby under any intellectual property rights or other rights of LAPIS Semiconductor or any third party with respect to the information contained in this document; therefore LAPIS Semiconductor shall have no responsibility whatsoever for any dispute, concerning such rights owned by third parties, arising out of the use of such technical information.
- 5) The Products are intended for use in general electronic equipment (i.e. AV/OA devices, communication, consumer systems, gaming/entertainment sets) as well as the applications indicated in this document.
- 6) The Products specified in this document are not designed to be radiation tolerant.
- 7) For use of our Products in applications requiring a high degree of reliability (as exemplified below), please contact and consult with a LAPIS Semiconductor representative: transportation equipment (i.e. cars, ships, trains), primary communication equipment, traffic lights, fire/crime prevention, safety equipment, medical systems, servers, solar cells, and power transmission systems.
- 8) Do not use our Products in applications requiring extremely high reliability, such as aerospace equipment, nuclear power control systems, and submarine repeaters.
- 9) LAPIS Semiconductor shall have no responsibility for any damages or injury arising from non-compliance with the recommended usage conditions and specifications contained herein.
- 10) LAPIS Semiconductor has used reasonable care to ensure the accuracy of the information contained in this document. However, LAPIS Semiconductor does not warrant that such information is error-free and LAPIS Semiconductor shall have no responsibility for any damages arising from any inaccuracy or misprint of such information.
- 11) Please use the Products in accordance with any applicable environmental laws and regulations, such as the RoHS Directive. For more details, including RoHS compatibility, please contact a ROHM sales office. LAPIS Semiconductor shall have no responsibility for any damages or losses resulting non-compliance with any applicable laws or regulations.
- 12) When providing our Products and technologies contained in this document to other countries, you must abide by the procedures and provisions stipulated in all applicable export laws and regulations, including without limitation the US Export Administration Regulations and the Foreign Exchange and Foreign Trade Act.
- 13) This document, in part or in whole, may not be reprinted or reproduced without prior consent of LAPIS Semiconductor.

Copyright 2007 – 2017 LAPIS Semiconductor Co., Ltd.

LAPIS Semiconductor Co.,Ltd.

2-4-8 Shinyokohama, Kouhoku-ku,
Yokohama 222-8575, Japan
<http://www.lapis-semi.com/en/>